

Centre Number	Candidate Number	Name
---------------	------------------	------

CAMBRIDGE INTERNATIONAL EXAMINATIONS
International General Certificate of Secondary Education

COMBINED SCIENCE
CO-ORDINATED SCIENCES

0653/06
0654/06

Paper 6 Alternative to Practical

May/June 2003

1 hour

Candidates answer on the Question Paper.
No Additional Materials are required.

READ THESE INSTRUCTIONS FIRST

Write your Centre number, candidate number and name on all the work you hand in.
Write in dark blue or black pen in the spaces provided on the Question Paper.
You may use a soft pencil for any diagrams, graphs or rough working.
Do not use staples, paper clips, highlighters, glue or correction fluid.

Answer **all** questions.

At the end of the examination, fasten all your work securely together.

The number of marks is given in brackets [] at the end of each question or part question.

If you have been given a label, look at the details. If any details are incorrect or missing, please fill in your correct details in the space given at the top of this page.

Stick your personal label here, if provided.

For Examiner's Use	
1	
2	
3	
4	
5	
6	
Total	

- 1 A student did an experiment to compare the rates of transpiration of leafy shoots from two different plants, *elder* and *pyrocantha*. She selected shoots from both plants of the same mass and stem diameter. She used the potometer shown in Fig. 1.1.

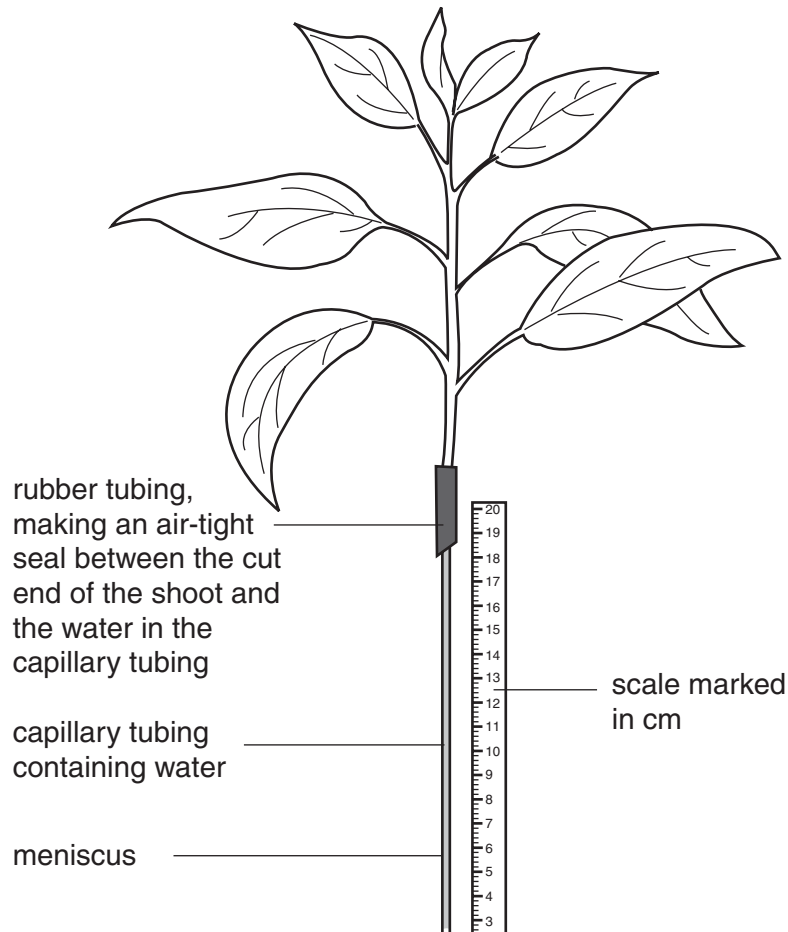

Fig. 1.1

She took readings of the height of the meniscus **every 10 seconds for 90 seconds**. Her results are below.

results for *elder*

reading of meniscus at start = 1.6 cm

reading / cm	2.4	2.9	3.5	4.0	4.6	5.2	5.6	6.2	6.6
--------------	-----	-----	-----	-----	-----	-----	-----	-----	-----

results for *pyrocantha*

reading of meniscus at start = 0.8 cm

reading / cm	2.5	4.2	5.3	8.2	10.2	12.2	14.1	16.0	18.0
--------------	-----	-----	-----	-----	------	------	------	------	------

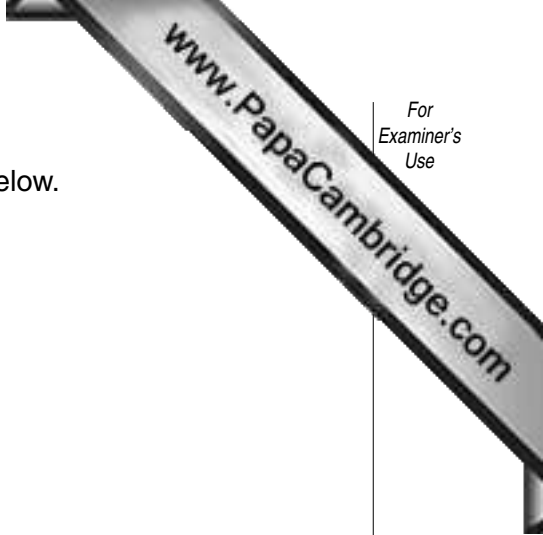

(a) Construct a table showing times and readings in the space below.

[3]

(b) Work out the average water loss for each plant in centimetres of water per second. Show your working.

elder

average water loss = cm/s

pyrocantha

average water loss = cm/s

[4]

(c) Suggest one difference between the shoots that could account for the different rates of water loss. Explain your answer.

difference

explanation

.....[2]

(d) Name **one environmental** factor that could account for the different rates of water loss of the two shoots.

.....[1]

- 2 A student was given one piece of each of the metals copper, magnesium and zinc. She did three experiments to find the potential difference set up between the metals. The apparatus is shown in the diagram, Fig. 2.1.

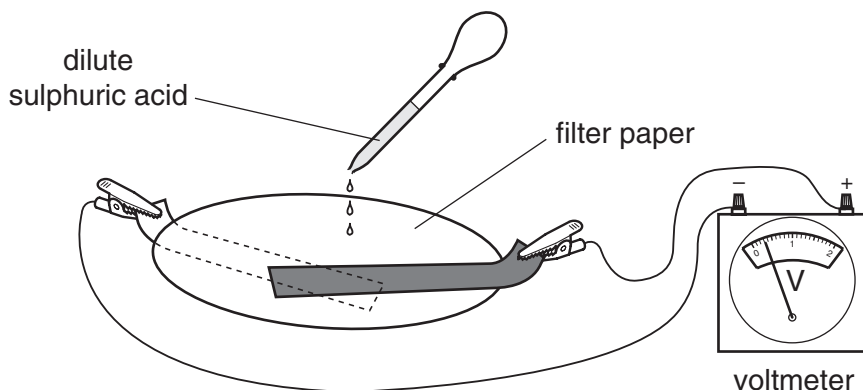

Fig. 2.1

- She connected the metals magnesium and zinc to the voltmeter and placed a filter paper between them (see Fig. 2.1).
- She moistened the filter paper with dilute sulphuric acid.
- She read the voltmeter and noted the result in the table, Fig. 2.3.

- (a) The diagrams of the voltmeter scales, Fig. 2.2, show the potential differences between the other two pairs of metals.

Read the scales and record the results in the table, Fig. 2.3.

[4]

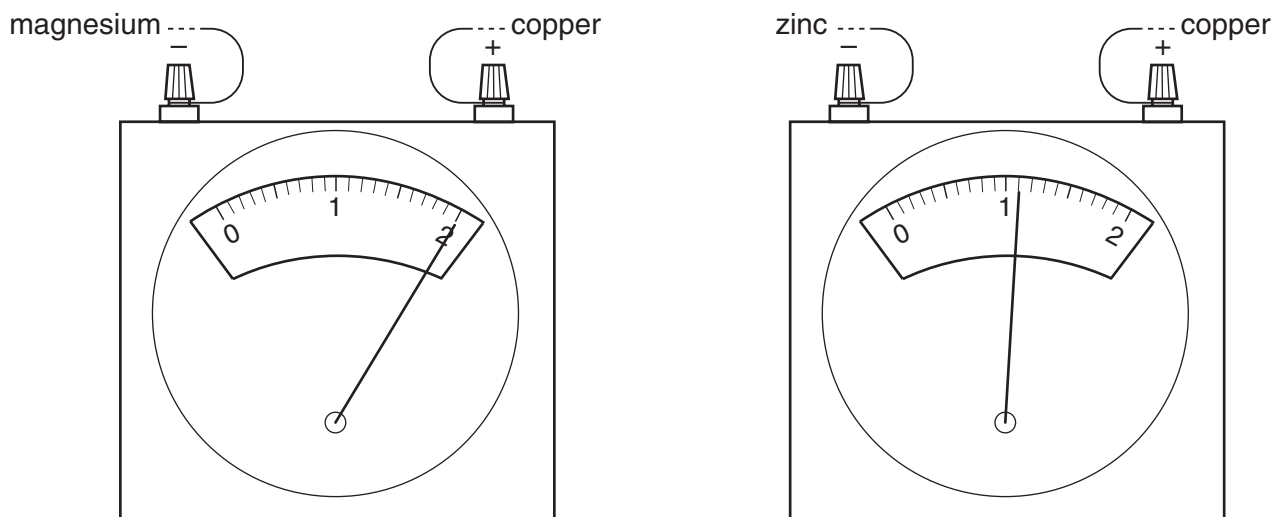

Fig. 2.2

experiment no.	metal connected to the negative terminal (-) of the voltmeter	metal connected to the positive terminal (+) of the voltmeter	potential difference / V
1	magnesium	zinc	1.6
2			
3			

Fig. 2.3

(b) From the results, state which of the three metals is

(i) the most negative,

(ii) the most positive.

[2]

(c) Place the metals copper, magnesium and zinc in order of their reactivity, most reactive first.

most reactive

.....

least reactive

[1]

(d) The student was given a piece of another metal, **X**. The teacher did not tell her the name of this metal.

Describe an experiment to find the correct place for metal **X** in the order of reactivity that you have stated in (c).

.....

.....

.....

.....[3]

- 3 A student did an experiment to investigate the relationship between the applied force and extension of a spring.

He used the apparatus shown in the diagram, Fig. 3.1.

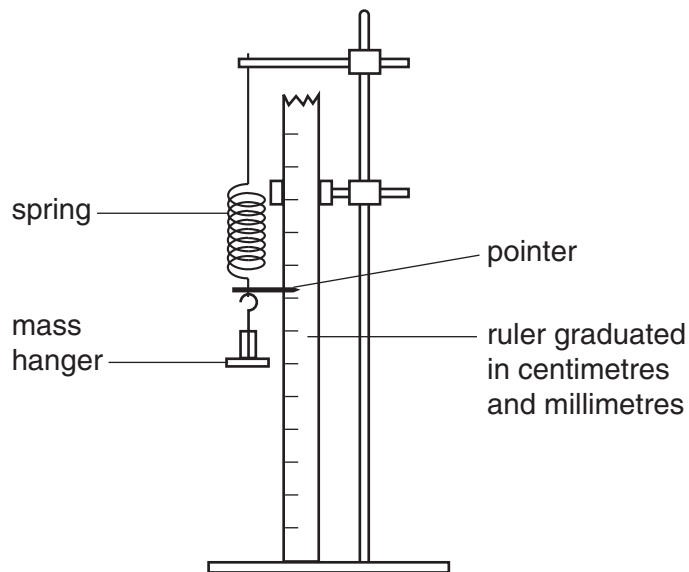

Fig. 3.1

The student hung a mass hanger on the spring.

- He read off the height, h_0 , of the pointer and recorded it in the table, Fig. 3.3.
- He added a 50 g mass to the mass hanger.
- He found the height, h_1 , of the pointer and recorded it in the table.
- He added more 50 g masses, each time recording the height, h , until 250 g had been added.

Fig. 3.2 shows the heights of the pointer and the scale of the ruler for the masses 150 g, 200 g and 250 g.

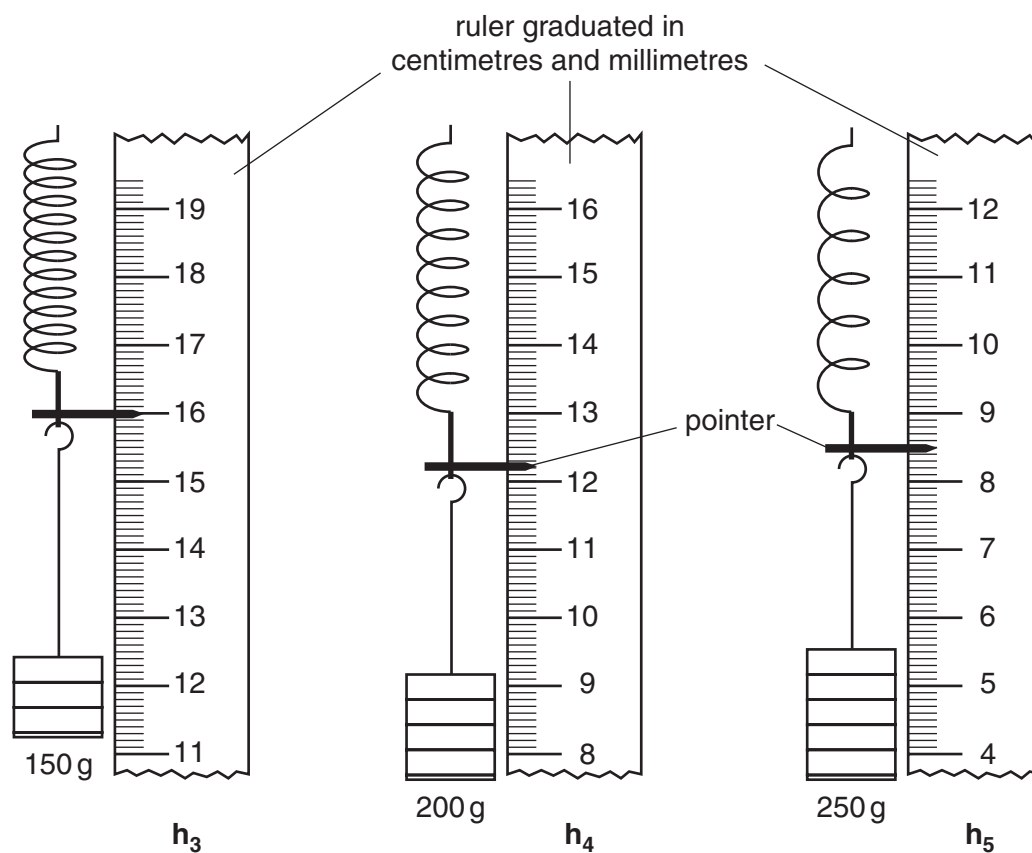
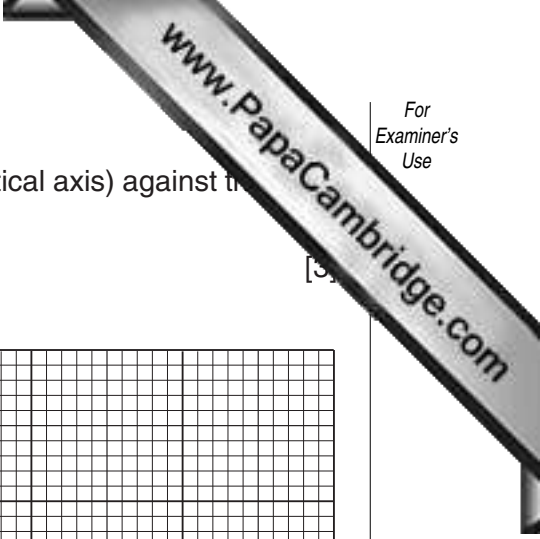

Fig. 3.2

- (a) Read the heights, h_3 , h_4 and h_5 in Fig. 3.2, to the nearest mm, and record them in the table, Fig. 3.3. [2]
- (b) Complete Fig. 3.3, noting that you are required to convert each mass into a force. ($1000\text{ g} = 10\text{ N}$) Calculate the total increase in length of the spring (the extension) for each mass added. [2]

total mass added / g	force / N	height h / mm	total increase in length (extension) / mm
0	0	$h_0 = 270$	0
50	0.5	$h_1 = 233$	37
100	1.0	$h_2 = 195$	75
150		$h_3 =$	
200		$h_4 =$	
250		$h_5 =$	

Fig. 3.3



(c) On the graph grid provided, plot a graph of the extension (vertical axis) against the force (horizontal axis).

Draw the best straight line through these points. [3]

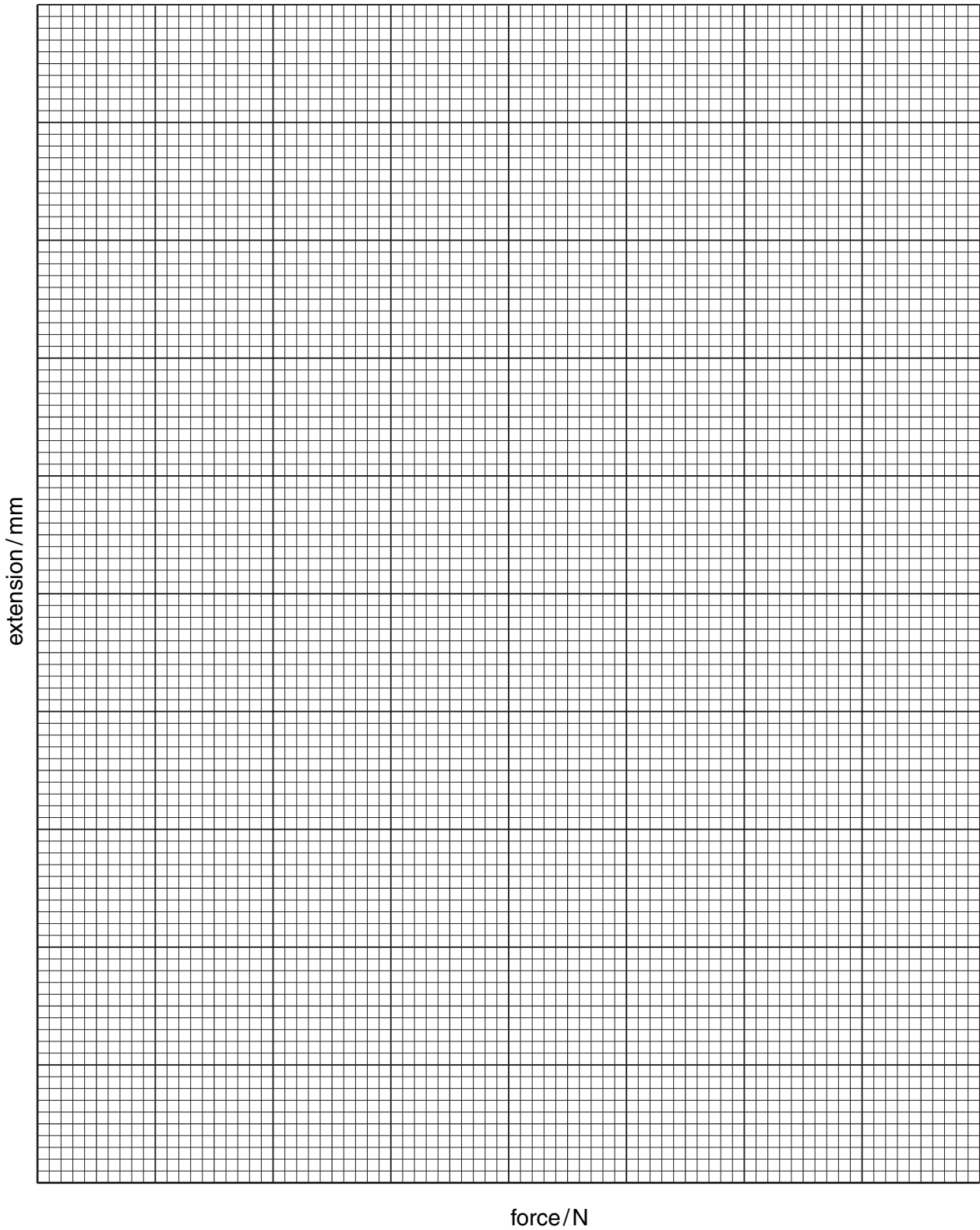

(d) What is the relationship between the applied force and the extension of the spring?

.....[1]

- (e) Describe how you would find the mass of an object using the same apparatus. You need to state the measurements you would make and show how the mass can be calculated.

.....

.....

.....

.....[2]

- 4 A student did an experiment to find out what is produced when bread is burned in air. In some ways the process is similar to respiration in the cells of the body.

He used the apparatus shown in Fig. 4.1(a).

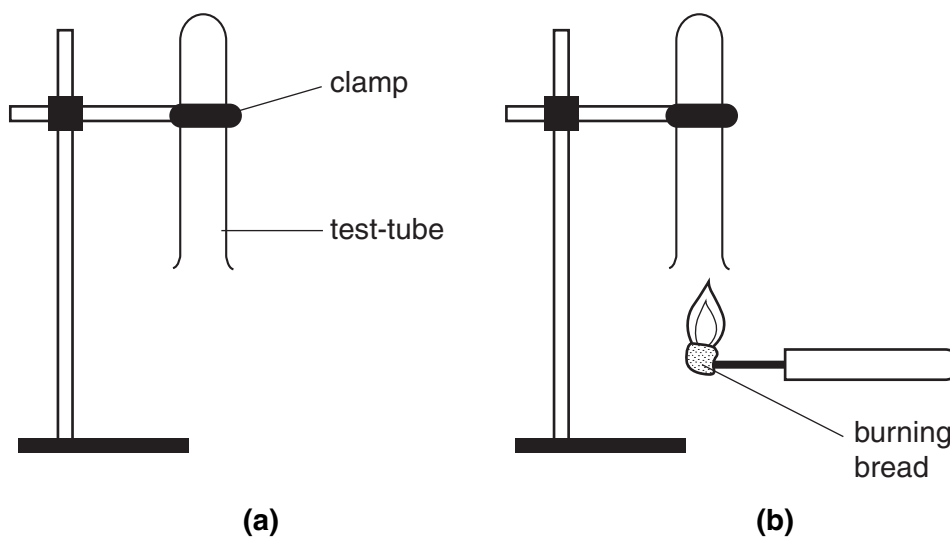

Fig. 4.1

- He pushed a piece of bread onto a mounted needle.
- He set fire to it, then held it beneath the test-tube as shown in Fig. 4.1(b).
- He let it burn for fifteen seconds, then he put out the flame and placed a bung in the tube.
- He then did some tests on the tube and its contents.

(a) (i) Complete the table below.

test	observation	conclusion
he felt the sides of the tube	the sides felt warm	
he looked at the sides of the tube	the sides looked misty	water vapour was produced
he added limewater to the tube and shook it		carbon dioxide was present

[2]

(ii) Describe one way in which respiration in our body cells is different from the burning of bread.

.....
.....[1]

(b) The bread contained starch. The body cannot use starch until it is broken down by enzymes in our digestive system.

The student was given two beakers, **A** and **B**. One beaker contained a starch solution and the other contained protein solution.

He took small amounts of solution from each beaker and added Biuret solution to them. He recorded his conclusions in the table.

(i) Complete the table with his observations.

beaker	colour observed	conclusion
A		no protein
B		protein

[2]

(ii) How could the student confirm that beaker **A** contained starch?

test

result[2]

(c) The student did an experiment to find out if the protein was an enzyme that breaks down starch.

- He mixed equal amounts of solution **A** and **B** in a test-tube.
- He left the tube for five minutes.
- Then he added Benedict's solution to the tube and heated it.

The contents of the test-tube turned red.

(i) What did the red colour indicate?

.....[1]

(ii) Was the protein solution an enzyme? Explain your answer.

.....

.....

.....[2]

- 5 (a) A student placed a crystal of potassium manganate(VII) in a test-tube of water. She stood the test-tube in a rack and left it there. The diagrams, Fig. 5.1, show what the test-tube looked like after two hours and after one day.

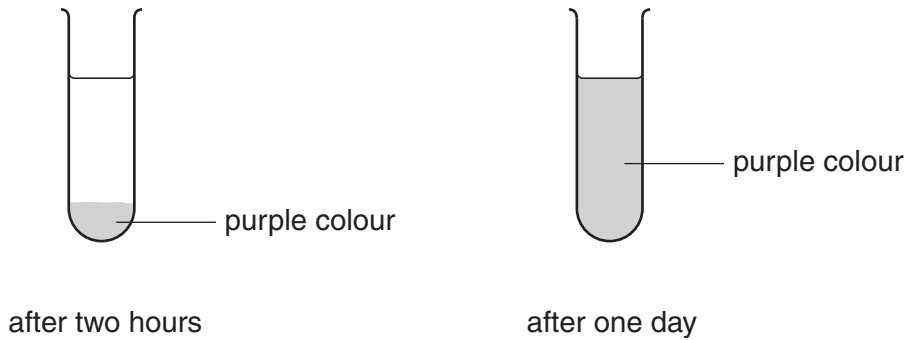

Fig. 5.1

- (i) Explain what happened to the particles in the crystal.

.....

[2]

- (ii) Suggest two ways to speed up the processes happening in the tube.

1.
 2.[2]

- (b) Calcium hydroxide is a white solid that is slightly soluble in water. The student placed some calcium hydroxide into a test-tube with five drops of Universal Indicator. The Universal Indicator turned purple.

What does this colour tell you about the calcium hydroxide?

.....[1]

- (c) The student carefully poured some dilute ethanoic acid into the mixture from (b) the tube in the rack. Fig. 5.2 shows what the tube looked like after a few hours.

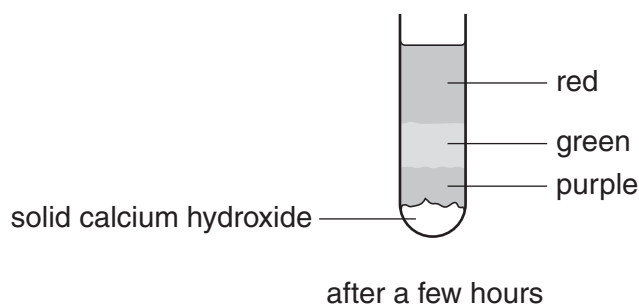

Fig. 5.2

- (i) Explain the meaning of the word *dilute*.
[1]
- (ii) Explain what has happened in the green part of the solution.

[2]
- (iii) Explain what has happened in the purple part of the solution.

[1]
- (iv) Write a word equation for the reaction that has taken place in the tube.
[1]

- 6 A student does an experiment to find out what happens when sodium chloride is dissolved in water. She measures 50 cm^3 of water into a weighed beaker and adds some sodium chloride crystals. Then she stirs the mixture to make the sodium chloride dissolve. The diagrams, Fig. 6.1, show the balance readings for the three weighings.

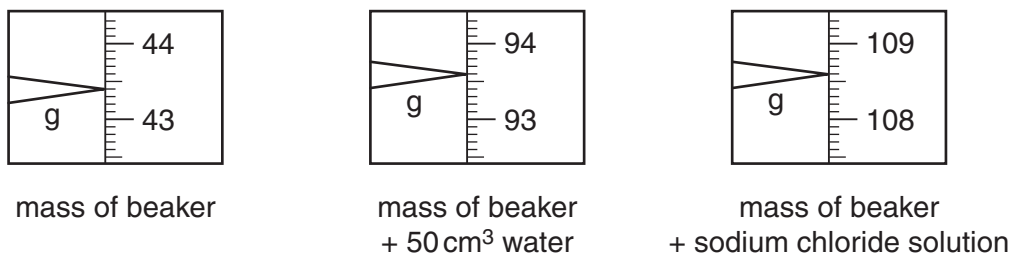

Fig. 6.1

- (a) Record the balance readings.

mass of the beaker = g

mass of the beaker + 50 cm^3 water = g

mass of the beaker + sodium chloride solution = g

[3]

- (b) (i) Calculate the mass of the sodium chloride solution.

mass of sodium chloride solution = g

[1]

- (ii) Calculate the mass of the sodium chloride crystals.

mass of sodium chloride crystals = g

[1]

[Question 6 continues on page 16]

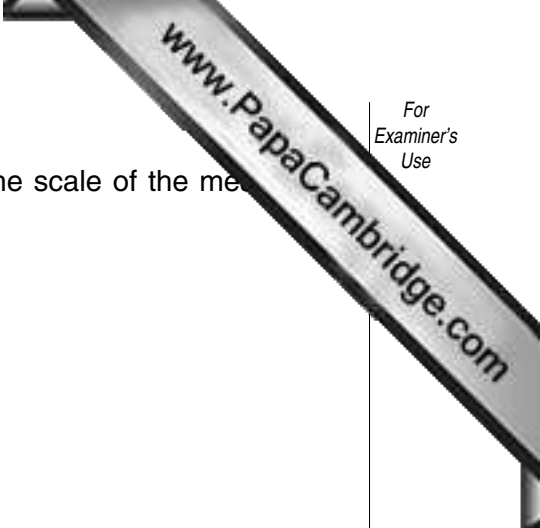

- (c) The student pours the solution into a measuring cylinder. The scale of the measuring cylinder is shown in Fig. 6.2.

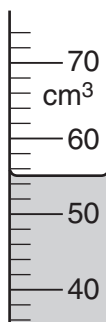

Fig. 6.2

What is the volume of the solution?

..... cm³ [1]

- (d) Which of the experimental results in (a), (b) and (c) must the student use to calculate the **density** of sodium chloride solution?

.....
[1]

- (e) The student wants to do an experiment to find the volume of the solid sodium chloride crystals. The teacher tells her that sodium chloride will not dissolve in hexane, an organic liquid.

Explain how she can use hexane and a 50 cm³ measuring cylinder to find the accurate **volume** of 15 g of sodium chloride crystals.

.....

[3]