



UNIVERSITY OF CAMBRIDGE INTERNATIONAL EXAMINATIONS
International General Certificate of Secondary Education

www.PapaCambridge.com

CO-ORDINATED SCIENCES

0654/01

Paper 1 Multiple Choice

May/June 2008

45 minutes

Additional Materials: Multiple Choice Answer Sheet
Soft clean eraser
Soft pencil (type B or HB is recommended)

* 8 4 3 7 2 3 3 0 2 1 *

READ THESE INSTRUCTIONS FIRST

Write in soft pencil.
Do not use staples, paper clips, highlighters, glue or correction fluid.
Write your name, Centre number and candidate number on the Answer Sheet in the spaces provided unless this has been done for you.

There are **forty** questions on this paper. Answer **all** questions. For each question there are four possible answers **A, B, C** and **D**.
Choose the **one** you consider correct and record your choice in **soft pencil** on the separate Answer Sheet.

Read the instructions on the Answer Sheet very carefully.

Each correct answer will score one mark. A mark will not be deducted for a wrong answer.
Any rough working should be done in this booklet.
A copy of the Periodic Table is printed on page 20.

This document consists of **20** printed pages.



- 1 The diagram shows an animal whose scientific name is *Falco tinniculus*.



To which species does it belong?

- A bird
 - B *Falco*
 - C *tinniculus*
 - D vertebrate
- 2 Which diagram shows the position of the cell wall?

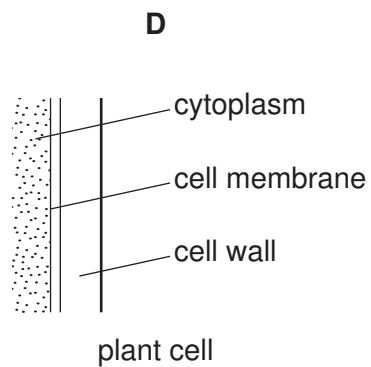
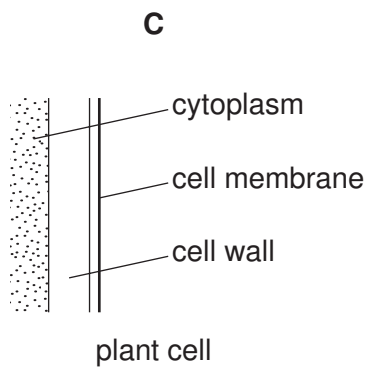
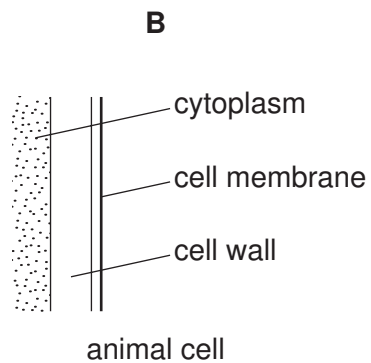
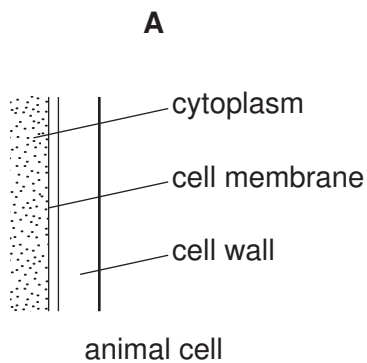

3 Which diagram shows how plants obtain chemicals for making proteins?

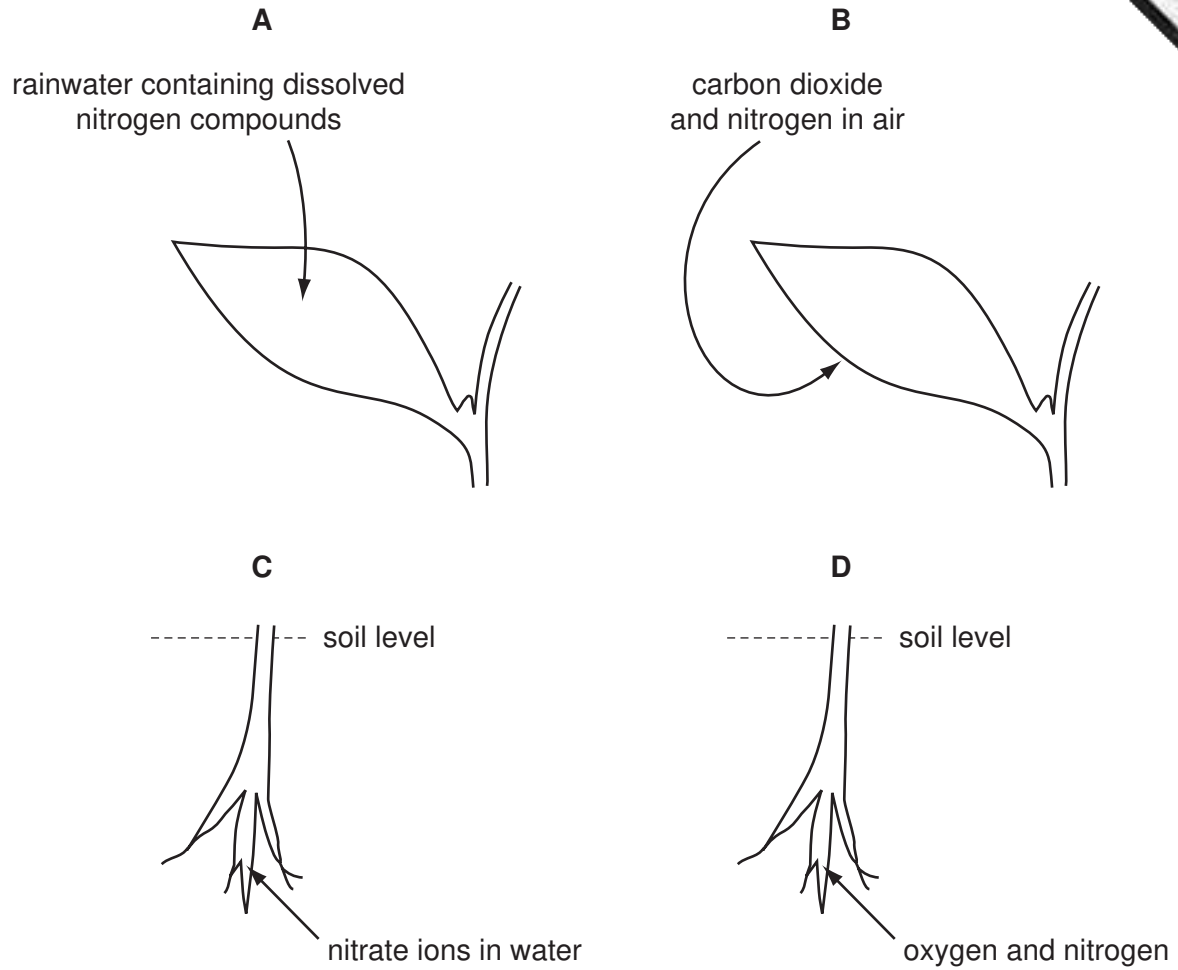

4 What is the purpose of respiration?

- A to improve breathing
- B to produce carbon dioxide
- C to release energy
- D to use up oxygen

- 5 The arrow shows urea leaving a cell and passing into structure P.

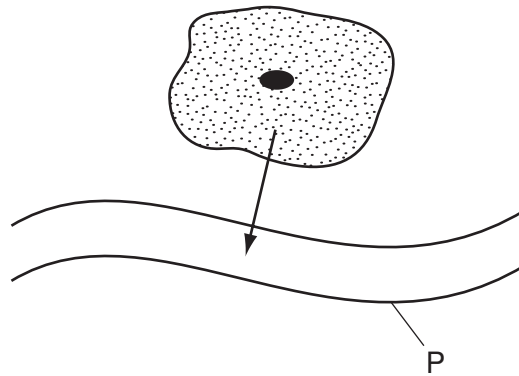

What is P?

- A a capillary
 - B an artery
 - C a vein
 - D the small intestine
- 6 The diagram shows a section through an alveolus and a blood capillary.

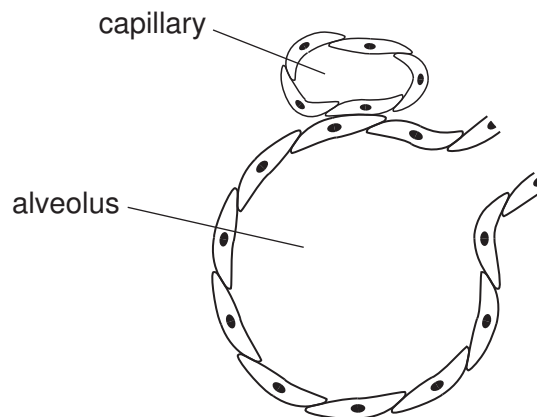

Why does oxygen move from the alveolus to the blood capillary?

- A It diffuses through because of a difference in concentration.
- B It is forced through the wall of the alveolus by air pressure.
- C It passes through because carbon dioxide is coming out.
- D It is sucked in by movement of blood in the capillary.

- 7 Kwashiorkor is a disease that affects young children who do not have enough protein. Which is the best food to add to a diet largely of carbohydrate to prevent kwashiorkor?
- A bread
 - B fish
 - C fruit
 - D rice

- 8 The diagram shows a section through the elbow joint.

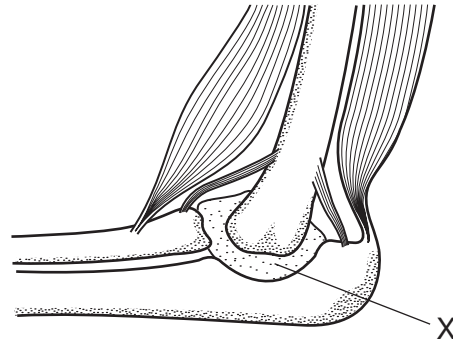

What is the purpose of the liquid at X?

- A to carry oxygen
- B to cause movement
- C to cool the joint
- D to reduce friction

- 9 The graph shows changes in the concentration of sugar in the blood after a person eats a spoonful of honey.

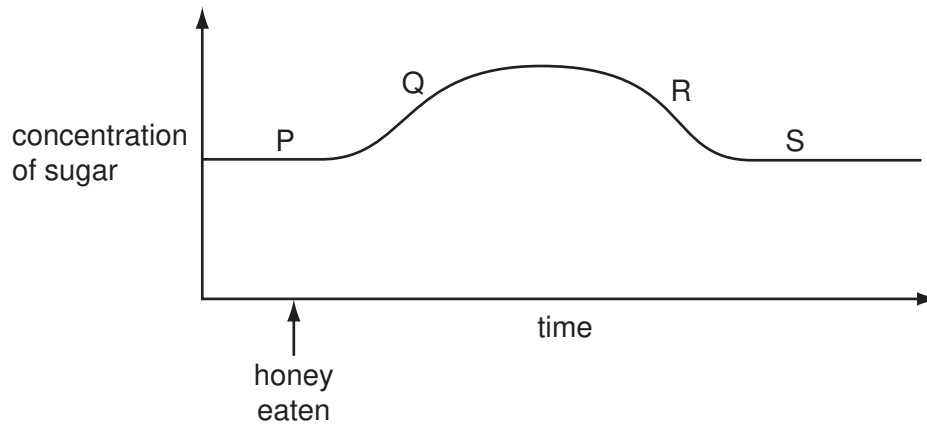

At which points on the curve is insulin being produced?

	P	Q	R	S
A	no	yes	yes	no
B	yes	no	no	no
C	no	yes	no	yes
D	yes	yes	yes	no

- 10 In a plant, what leads to offspring that are identical to the parent?

- A asexual reproduction
- B insect-pollination
- C seed dispersal
- D self-fertilisation

11 The diagram shows a developing fetus attached to the uterus wall.

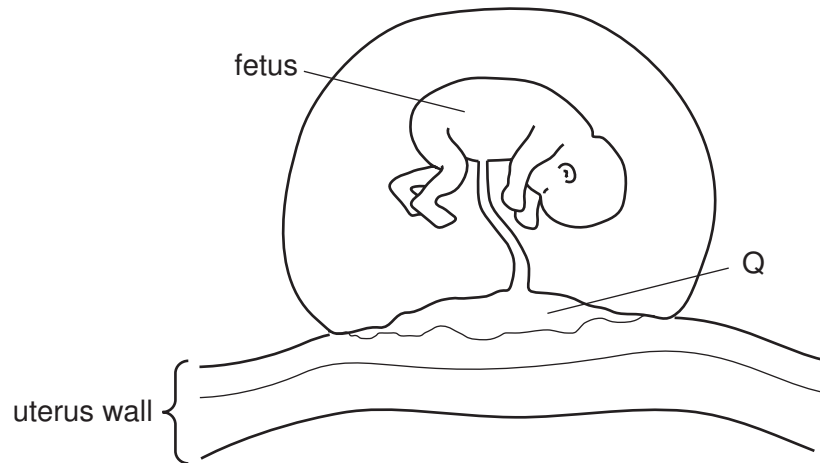

What is the function of Q?

- A filtering amniotic fluid
 - B passing blood from the mother to the fetus
 - C supplying oxygen to the fetus
 - D supplying urea to the fetus
- 12 What, together with the habitat in which it lives, forms an ecosystem?
- A a class
 - B a community
 - C a population
 - D a species
- 13 What must be controlled to protect the habitat of an endangered species?
- A decomposers
 - B nitrogen fixation
 - C pollution
 - D rainfall

14 What do the chemical symbols N_2 and Ni represent?

	N_2	Ni
A	a compound	a compound
B	a compound	an element
C	an element	a compound
D	an element	an element

15 The metal titanium occurs naturally combined with oxygen.

The table shows the combining powers of the elements in this compound.

element	symbol	combining power
oxygen	O	2
titanium	Ti	4

What could be the formula of the compound?

- A** TiO_2 **B** Ti_2O **C** TiO_4 **D** Ti_4O_2

16 Which trends in physical properties are correct for the alkali metals down Group I?

	hardness	melting point
A	decreases	decreases
B	decreases	increases
C	increases	decreases
D	increases	increases

17 Processes used in the petrochemical industry include

- 1 cracking.
- 2 distillation.

For which of these processes is a catalyst used?

- A** both 1 and 2
B 1 only
C 2 only
D neither 1 nor 2

18 The reactions of glucose are shown.

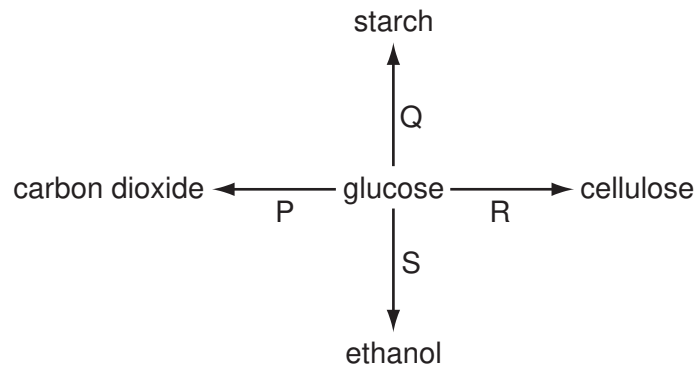

Which two reactions involve polymerisation?

- A** P and Q **B** P and R **C** Q and R **D** R and S

19 An alloy is used for making an aircraft body.

Which properties does this alloy need to have?

	low density	high electrical conductivity
A	no	no
B	no	yes
C	yes	no
D	yes	yes

20 How is carbon (coke) used in the extraction of iron from iron oxide?

- A** as an anode
B as a cathode
C as an oxidising agent
D as a reducing agent

- 21 Molten lead(II) bromide is electrolysed as shown. An element is deposited on an electrode.

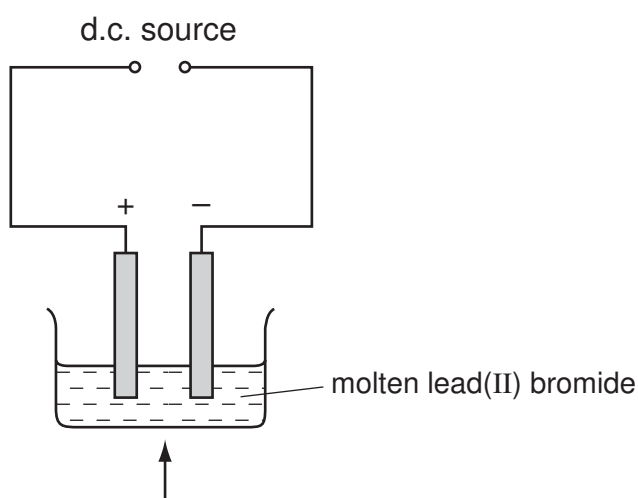

What is the name of the element and of the electrode?

	element	electrode
A	bromine	anode
B	bromine	cathode
C	lead	anode
D	lead	cathode

- 22 Soap solution is gradually added to separate samples of water P, Q, R and S until a lather forms.

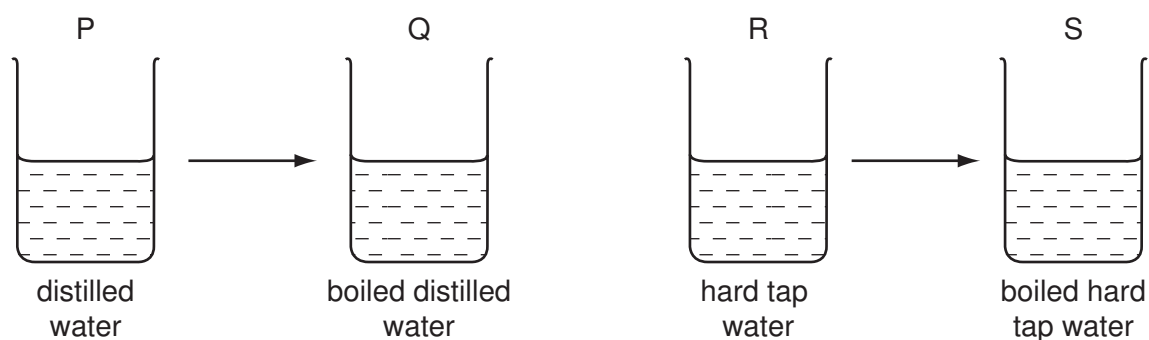

How does boiling affect the volume of soap solution needed for a lather?

	P → Q	R → S
A	no change	S needs less
B	no change	S needs more
C	Q needs more	S needs less
D	Q needs more	S needs more

23 Ammonia and sulphur dioxide are bubbled into separate samples of water.

What are the pH values of the resulting solutions?

	aqueous ammonia	aqueous sulphur dioxide
A	higher than 7	higher than 7
B	higher than 7	lower than 7
C	lower than 7	higher than 7
D	lower than 7	lower than 7

24 Fertilisers are used to supply the essential elements needed for plant growth.

Which compound supplies two of these essential elements?

- A** $\text{Ca}(\text{H}_2\text{PO}_4)_2$
- B** $\text{Ca}(\text{NO}_3)_2$
- C** KNO_3
- D** $(\text{NH}_4)_2\text{SO}_4$

25 The use of1..... to cure2..... is known as3..... .

Which words correctly complete gaps 1, 2 and 3?

	1	2	3
A	drugs	acidity	chromatography
B	drugs	cancer	chemotherapy
C	dyes	acidity	chromatography
D	emulsifiers	pollution	chemotherapy

26 Biogas is a mixture of gases. It is used as a fuel.

The diagram shows a biogas generator.

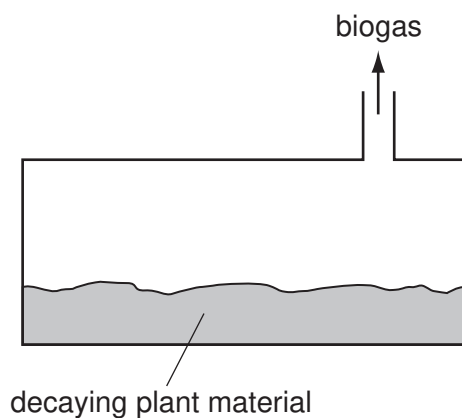

Which gas in the mixture burns?

- A methane
- B nitrogen
- C oxygen
- D water vapour

27 A student tests two solutions.

One solution is an aqueous copper salt. The other is an aqueous sodium salt.

How can the colours of the solutions and of flame tests show which solution is which?

	colour of solution		colour of flame	
	copper	sodium	copper	sodium
A	blue	colourless	blue	colourless
B	blue	colourless	green	yellow
C	green	yellow	blue	colourless
D	green	yellow	green	yellow

28 Some liquid is heated in a flask.

The diagrams show the height of the liquid in the tube when the liquid is cold and when it is hot.

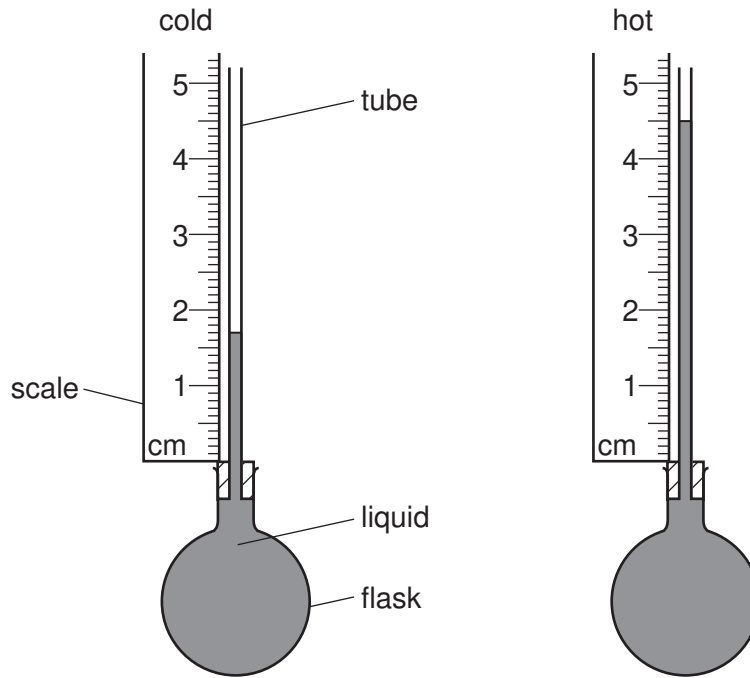

What is the difference in the heights?

- A** 1.7 cm **B** 2.8 cm **C** 3.2 cm **D** 4.5 cm

29 The speed-time graph shown is for a bus travelling between stops.

Where on the graph is the acceleration of the bus the greatest?

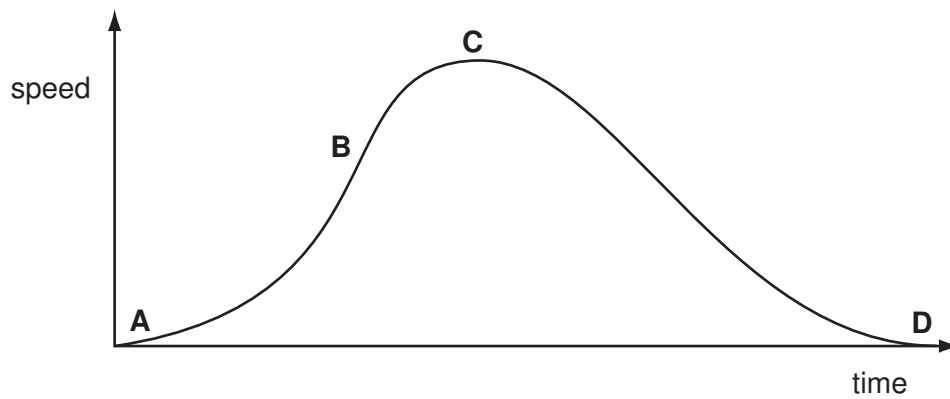

- 30 The circuit of a motor racing track is 3 km in length. In a race, a car goes 25 times round the circuit in 30 minutes.

What is the average speed of the car?

- A 75 km/hour
- B 90 km/hour
- C 150 km/hour
- D 750 km/hour

- 31 The diagram shows a rectangular metal block measuring 10 cm × 5.0 cm × 2.0 cm.

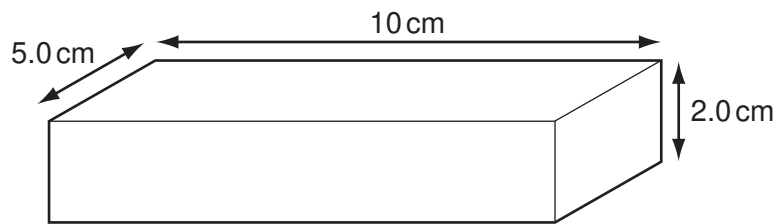

Its mass is 250 g.

What is the density of the metal?

- A 0.20 g/cm^3
- B 0.40 g/cm^3
- C 2.5 g/cm^3
- D 5.0 g/cm^3

32 A stone is thrown from the edge of a cliff. Its path is shown in the diagram.

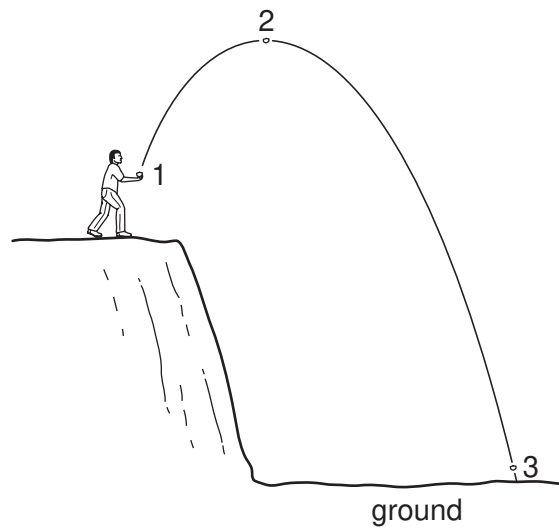

In which position does the stone have its greatest kinetic energy and in which position does it have its lowest potential energy?

	greatest kinetic energy	lowest potential energy
A	1	2
B	2	3
C	3	1
D	3	3

33 A heater is placed in a room.

Which diagram shows the movement of air as the room is heated?

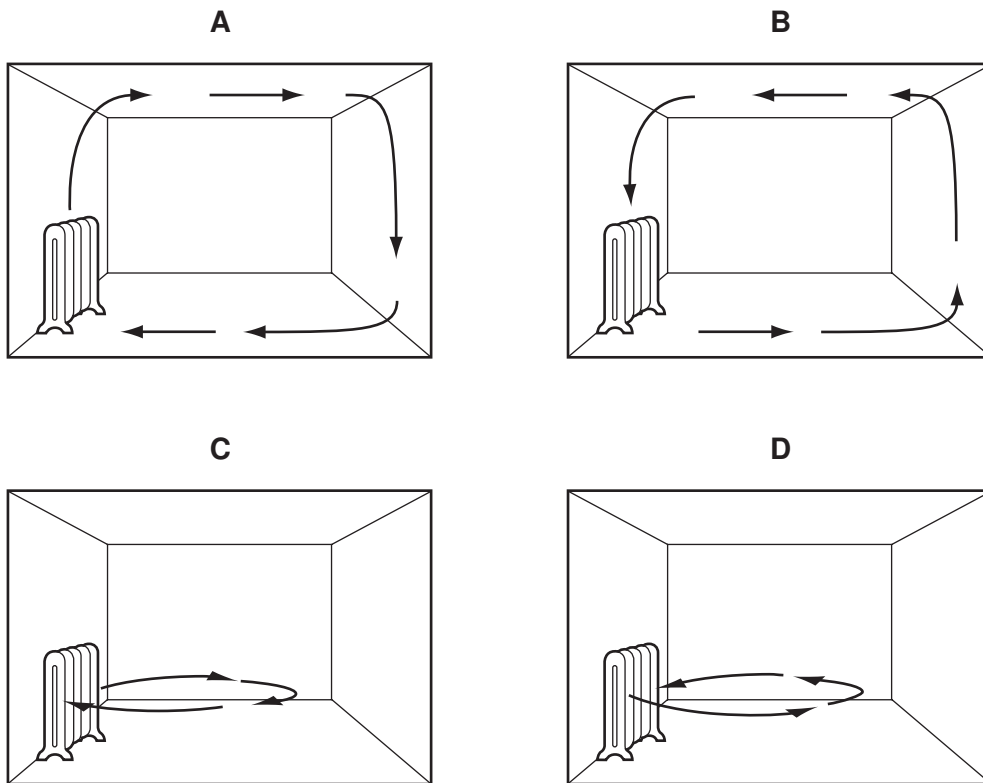

34 The diagram represents water waves about to move into shallow water from deep water.

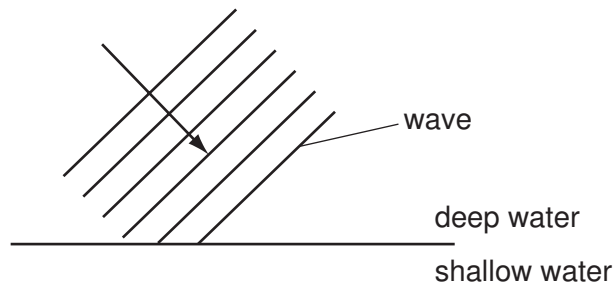

Which property of the waves remains the same after the waves move into shallow water?

- A frequency
- B speed
- C wave direction
- D wavelength

- 35 Rays from the Sun pass through a narrow slit and a spectrum is produced on a screen.

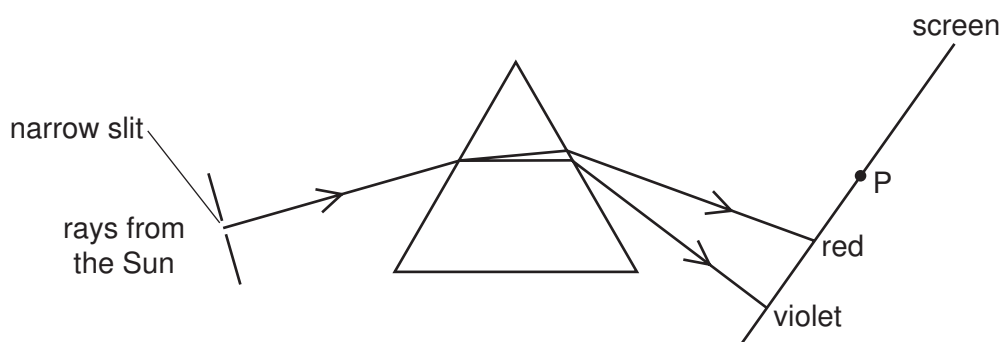

A thermometer placed at P shows a large temperature rise.

Which type of radiation causes this?

- A infra-red
 - B microwave
 - C ultraviolet
 - D visible light
- 36 Two thin converging lenses, X and Y, are used as shown to give a focused image of an illuminated slit. The rays shown are parallel between X and Y.

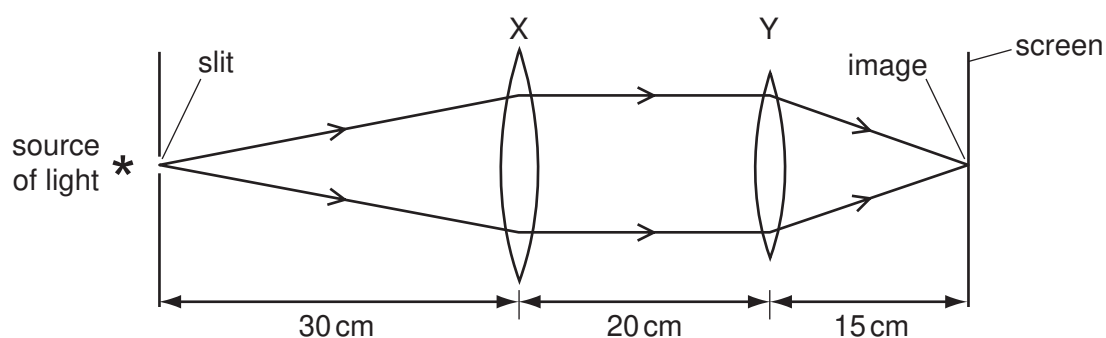

What are the correct values for the focal lengths of X and of Y?

	focal length of X/cm	focal length of Y/cm
A	50	35
B	30	20
C	30	15
D	20	20

- 37 In the circuit shown, the switches S_1 and S_2 may be open (off) or closed (on).

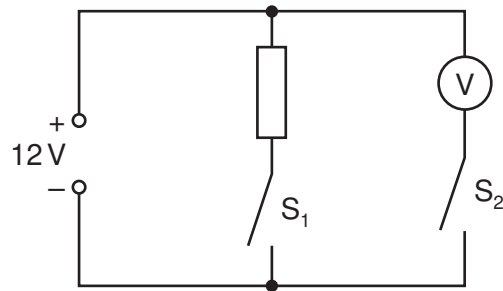

switches shown
open (off)

Which line in the table shows the voltmeter reading for the switch positions given?

	S_1	S_2	voltmeter reading / V
A	open	open	12
B	closed	closed	12
C	open	closed	0
D	closed	open	12

- 38 In order to produce a beam of cathode rays, a heated filament is placed near to an anode in an evacuated glass vessel.

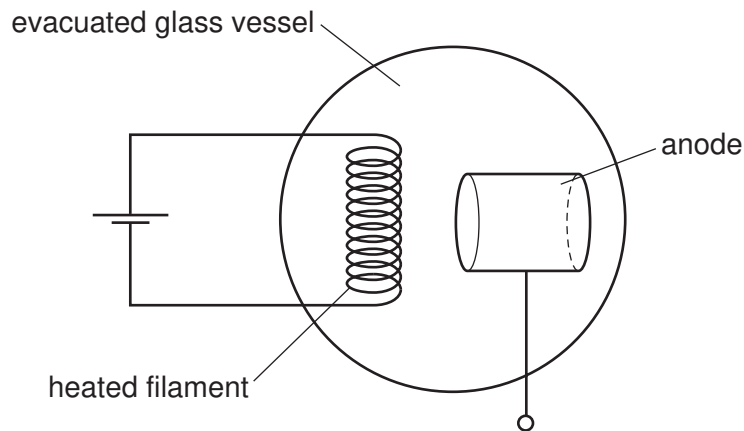

What is the type of charge given to the anode and why is this charge chosen?

	charge	reason
A	negative	to attract electrons
B	negative	to repel electrons
C	positive	to attract electrons
D	positive	to repel electrons

39 There are three types of emission from radioactive substances.

Which types carry an electric charge?

- A alpha radiation and beta radiation only
- B alpha radiation and gamma radiation only
- C beta radiation and gamma radiation only
- D all three types

40 A sample of radioactive uranium has mass 1g. Another sample of the same material has mass 2g.

Which property is the same for both samples?

- A the amount of radiation emitted per second
- B the half-life
- C the number of uranium atoms
- D the volume

DATA SHEET

The Periodic Table of the Elements

Group																									
I	II												III	IV	V	VI	VII	0							
													1 H Hydrogen 1												4 He Helium 2
7 Li Lithium 3	9 Be Beryllium 4												11 B Boron 5	12 C Carbon 6	14 N Nitrogen 7	16 O Oxygen 8	19 F Fluorine 9	20 Ne Neon 10							
23 Na Sodium 11	24 Mg Magnesium 12												27 Al Aluminium 13	28 Si Silicon 14	31 P Phosphorus 15	32 S Sulphur 16	35.5 Cl Chlorine 17	40 Ar Argon 18							
39 K Potassium 19	40 Ca Calcium 20	45 Sc Scandium 21	48 Ti Titanium 22	51 V Vanadium 23	52 Cr Chromium 24	55 Mn Manganese 25	56 Fe Iron 26	59 Co Cobalt 27	59 Ni Nickel 28	64 Cu Copper 29	65 Zn Zinc 30	70 Ga Gallium 31	73 Ge Germanium 32	75 As Arsenic 33	79 Se Selenium 34	80 Br Bromine 35	84 Kr Krypton 36								
85 Rb Rubidium 37	88 Sr Strontium 38	89 Y Yttrium 39	91 Zr Zirconium 40	93 Nb Niobium 41	96 Mo Molybdenum 42	96 Tc Technetium 43	101 Ru Ruthenium 44	103 Rh Rhodium 45	106 Pd Palladium 46	108 Ag Silver 47	112 Cd Cadmium 48	115 In Indium 49	119 Sn Tin 50	122 Sb Antimony 51	128 Te Tellurium 52	127 I Iodine 53	131 Xe Xenon 54								
133 Cs Caesium 55	137 Ba Barium 56	139 La Lanthanum 57 *	178 Hf Hafnium 72	181 Ta Tantalum 73	184 W Tungsten 74	186 Re Rhenium 75	190 Os Osmium 76	192 Ir Iridium 77	195 Pt Platinum 78	197 Au Gold 79	201 Hg Mercury 80	204 Tl Thallium 81	207 Pb Lead 82	209 Bi Bismuth 83	Po Polonium 84	At Astatine 85	Rn Radon 86								
Fr Francium 87	226 Ra Radium 88	227 Ac Actinium 89 †																							

*58-71 Lanthanoid series

†90-103 Actinoid series

Key

a	a = relative atomic mass
X	X = atomic symbol
b	b = proton (atomic) number

140 Ce Cerium 58	141 Pr Praseodymium 59	144 Nd Neodymium 60	Pm Promethium 61	150 Sm Samarium 62	152 Eu Europium 63	157 Gd Gadolinium 64	159 Tb Terbium 65	162 Dy Dysprosium 66	165 Ho Holmium 67	167 Er Erbium 68	169 Tm Thulium 69	173 Yb Ytterbium 70	175 Lu Lutetium 71
232 Th Thorium 90	Pa Protactinium 91	238 U Uranium 92	Np Neptunium 93	Pu Plutonium 94	Am Americium 95	Cm Curium 96	Bk Berkelium 97	Cf Californium 98	Es Einsteinium 99	Fm Fermium 100	Md Mendelevium 101	No Nobelium 102	Lr Lawrencium 103

The volume of one mole of any gas is 24 dm³ at room temperature and pressure (r.t.p.).