

**PHYSICS**

**9702/12**

Paper 1 Multiple Choice

**October/November 2017**

**1 hour 15 minutes**

Additional Materials: Multiple Choice Answer Sheet  
Soft clean eraser  
Soft pencil (type B or HB is recommended)

\* 7 4 7 0 6 9 7 6 2 5 \*

**READ THESE INSTRUCTIONS FIRST**

Write in soft pencil.

Do not use staples, paper clips, glue or correction fluid.

Write your name, Centre number and candidate number on the Answer Sheet in the spaces provided unless this has been done for you.

**DO NOT WRITE IN ANY BARCODES.**

There are **forty** questions on this paper. Answer **all** questions. For each question there are four possible answers **A, B, C** and **D**.

Choose the **one** you consider correct and record your choice in **soft pencil** on the separate Answer Sheet.

**Read the instructions on the Answer Sheet very carefully.**

Each correct answer will score one mark. A mark will not be deducted for a wrong answer.

Any working should be done in this booklet.

Electronic calculators may be used.

This document consists of **20** printed pages.

**Data**

speed of light in free space	$c = 3.00 \times 10^8 \text{ m s}^{-1}$
permeability of free space	$\mu_0 = 4\pi \times 10^{-7} \text{ H m}^{-1}$
permittivity of free space	$\epsilon_0 = 8.85 \times 10^{-12} \text{ F m}^{-1}$ $(\frac{1}{4\pi\epsilon_0} = 8.99 \times 10^9 \text{ m F}^{-1})$
elementary charge	$e = 1.60 \times 10^{-19} \text{ C}$
the Planck constant	$h = 6.63 \times 10^{-34} \text{ J s}$
unified atomic mass unit	$1 \text{ u} = 1.66 \times 10^{-27} \text{ kg}$
rest mass of electron	$m_e = 9.11 \times 10^{-31} \text{ kg}$
rest mass of proton	$m_p = 1.67 \times 10^{-27} \text{ kg}$
molar gas constant	$R = 8.31 \text{ J K}^{-1} \text{ mol}^{-1}$
the Avogadro constant	$N_A = 6.02 \times 10^{23} \text{ mol}^{-1}$
the Boltzmann constant	$k = 1.38 \times 10^{-23} \text{ J K}^{-1}$
gravitational constant	$G = 6.67 \times 10^{-11} \text{ N m}^2 \text{ kg}^{-2}$
acceleration of free fall	$g = 9.81 \text{ m s}^{-2}$

**Formulae**

uniformly accelerated motion	$s = ut + \frac{1}{2}at^2$ $v^2 = u^2 + 2as$
work done on/by a gas	$W = p\Delta V$
gravitational potential	$\phi = -\frac{Gm}{r}$
hydrostatic pressure	$p = \rho gh$
pressure of an ideal gas	$p = \frac{1}{3}\frac{Nm}{V}\langle c^2 \rangle$
simple harmonic motion	$a = -\omega^2 x$
velocity of particle in s.h.m.	$v = v_0 \cos \omega t$ $v = \pm \omega \sqrt{(x_0^2 - x^2)}$
Doppler effect	$f_o = \frac{f_s v}{v \pm v_s}$
electric potential	$V = \frac{Q}{4\pi\epsilon_0 r}$
capacitors in series	$1/C = 1/C_1 + 1/C_2 + \dots$
capacitors in parallel	$C = C_1 + C_2 + \dots$
energy of charged capacitor	$W = \frac{1}{2}QV$
electric current	$I = Anvq$
resistors in series	$R = R_1 + R_2 + \dots$
resistors in parallel	$1/R = 1/R_1 + 1/R_2 + \dots$
Hall voltage	$V_H = \frac{BI}{ntq}$
alternating current/voltage	$x = x_0 \sin \omega t$
radioactive decay	$x = x_0 \exp(-\lambda t)$
decay constant	$\lambda = \frac{0.693}{t_{\frac{1}{2}}}$

1 Which pair of units are **not** the same when expressed in SI base units?

- A  $\text{ms}^{-2}$  and  $\text{Nkg}^{-1}$
- B  $\text{Ns}$  and  $\text{kg ms}^{-1}$
- C  $\text{Pa}$  and  $\text{Nm}^{-2}$
- D  $\text{Vm}^{-2}$  and  $\text{NC}^{-1}$

2 What is the vertical component of this displacement vector?

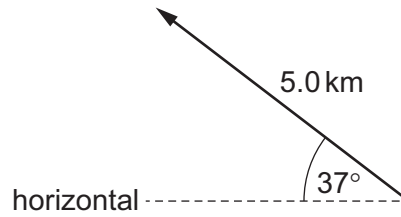

- A 3.0 km
- B 3.8 km
- C 4.0 km
- D 5.0 km

3 The units of specific heat capacity are  $\text{J kg}^{-1} \text{K}^{-1}$ .

What are the SI base units of specific heat capacity?

- A  $\text{ms}^{-2} \text{K}^{-1}$
- B  $\text{ms}^{-1} \text{K}^{-1}$
- C  $\text{m}^2 \text{s}^{-2} \text{K}^{-1}$
- D  $\text{m}^2 \text{s}^{-1} \text{K}^{-1}$

4 A quantity  $y$  is to be determined from the equation shown.

$$y = \frac{px}{q^2}$$

The percentage uncertainties in  $p$ ,  $x$  and  $q$  are shown.

	percentage uncertainty
$p$	6%
$x$	2%
$q$	4%

What is the percentage uncertainty in  $y$ ?

- A 0.5%
- B 0.75%
- C 12%
- D 16%

- 5 A transmitter emits a pulse of electromagnetic waves towards a reflector. The pulse is reflected and returns to the transmitter.

A detector is located at the transmitter. The emitted pulse and the reflected pulse are displayed on a cathode-ray oscilloscope (c.r.o.) as shown.

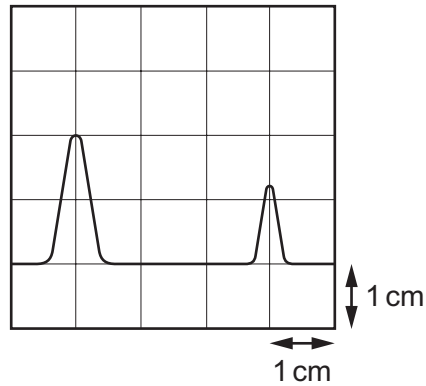

The pulse takes  $6.3 \mu\text{s}$  to travel from the transmitter to the reflector.

What is the time-base setting of the c.r.o.?

- A  $2.1 \mu\text{s cm}^{-1}$     B  $3.2 \mu\text{s cm}^{-1}$     C  $4.2 \mu\text{s cm}^{-1}$     D  $6.3 \mu\text{s cm}^{-1}$
- 6 A hot-air balloon is moving vertically upwards with a constant speed of  $3.00 \text{ m s}^{-1}$ . A sandbag is dropped from the balloon. It takes  $5.00 \text{ s}$  for the sandbag to fall to the ground.

What was the height of the balloon when the sandbag was released?

- A 29 m    B 108 m    C 123 m    D 138 m

- 7 The velocity-time graph for a train starting at one station and stopping at the next is shown.

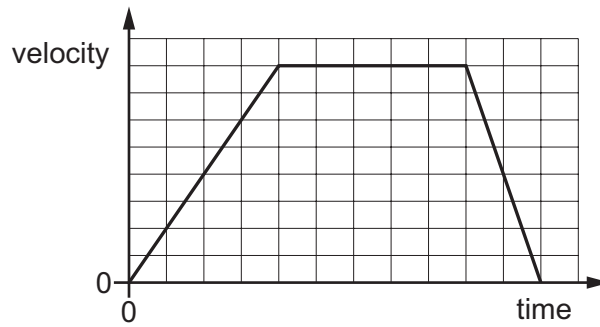

Another train has double the acceleration but the same maximum speed and the same deceleration.

Which velocity-time graph, on the same scale, shows the motion of this train between the same stations?

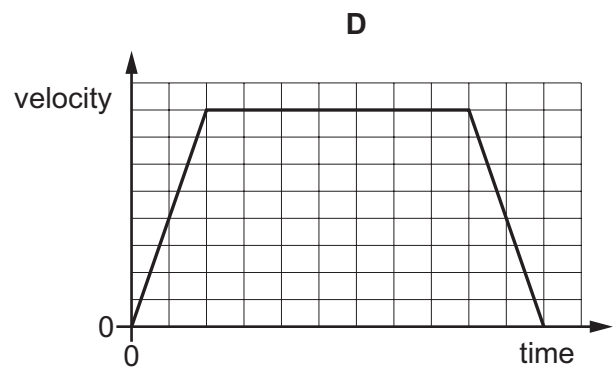
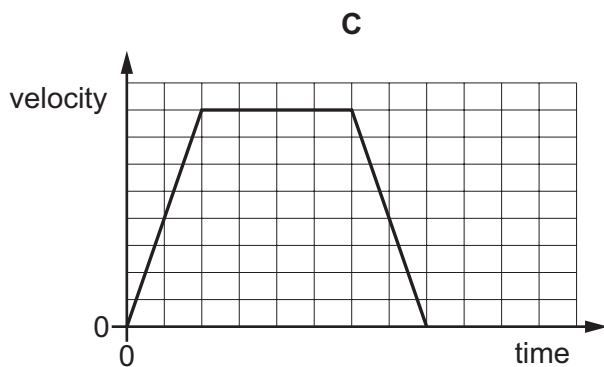
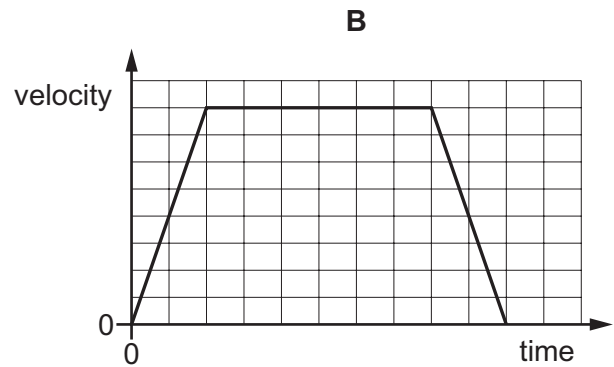
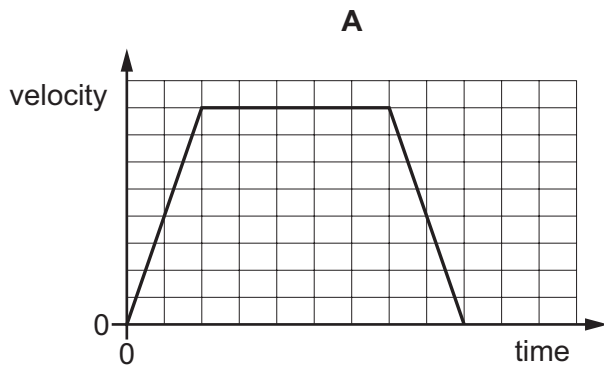

- 8 A stone is released from rest and falls a long distance in air.

Which graph could show the variation with time  $t$  of the acceleration  $a$  of the stone?

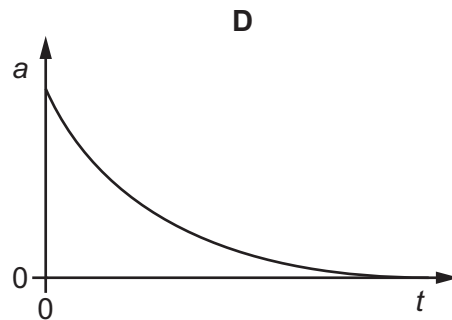
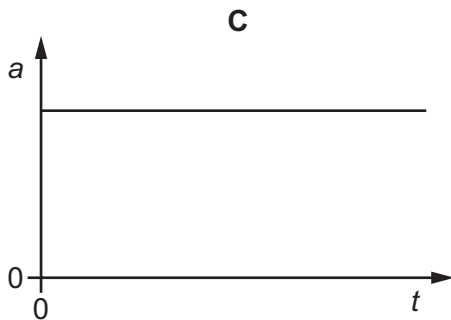
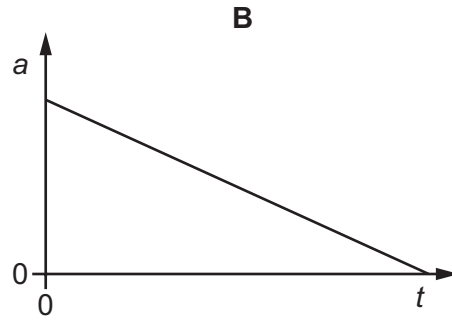
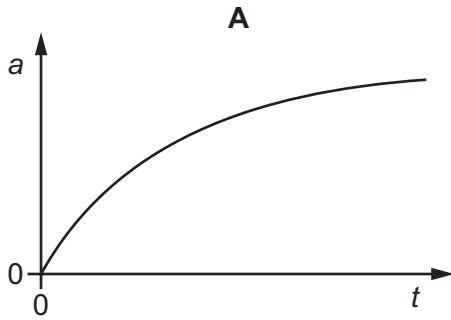

- 9 A slow vehicle and a fast vehicle travel towards each other in a straight line and then collide.

Which outcome is **never** possible, regardless of the masses of the vehicles?

- A** Both vehicles stop.
- B** Only one vehicle stops.
- C** The fast vehicle's speed increases.
- D** The slow vehicle's speed increases.

- 10 Two blocks of masses  $M$  and  $m$  are joined by a thin string which passes over a frictionless pulley, as shown.

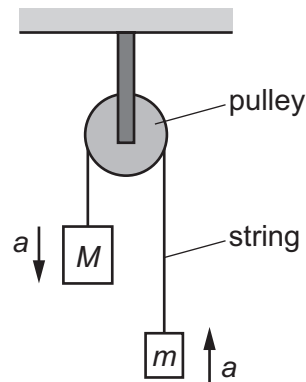

The acceleration of free fall is  $g$ .

What is the acceleration  $a$  of the two blocks?

- A  $\frac{(M+m)}{(M-m)}g$       B  $\frac{(M-m)}{(M+m)}g$       C  $\frac{M}{m}g$       D  $\frac{m}{M}g$

- 11 The diagram shows a block of copper suspended in water.

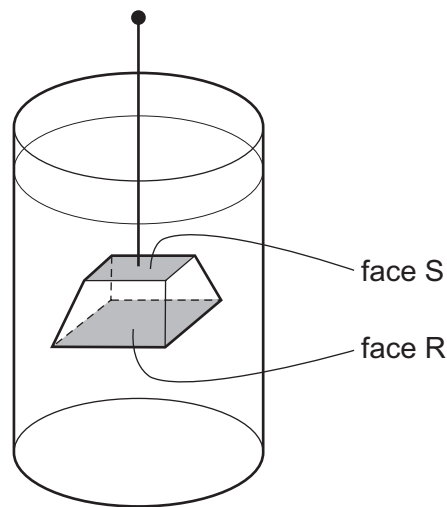

The block experiences an upthrust from the water.

Which statement is the basis of an explanation for this upthrust?

- A Copper is more dense than water.  
 B The area of face R is greater than the area of face S.  
 C The density of water increases with depth.  
 D The pressure of water increases with depth.



- 12 The diagram shows a solid cube with weight  $W$  and sides of length  $L$ . It is supported at rest by a frictionless spindle that passes through the centres of two opposite vertical faces. One of these faces is shaded.

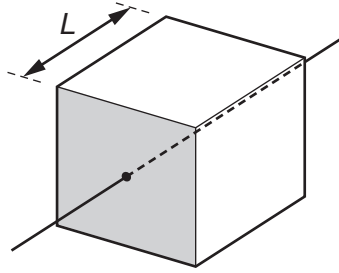

The spindle is now removed and replaced at a distance  $\frac{L}{4}$  to the right of its original position.

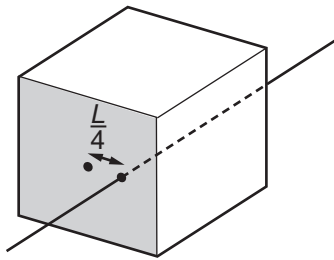

When viewing the shaded face, what is the torque of the couple that will now be needed to keep the cube at rest?

- A  $\frac{WL}{4}$  anticlockwise
- B  $\frac{WL}{4}$  clockwise
- C  $\frac{WL}{2}$  anticlockwise
- D  $\frac{WL}{2}$  clockwise

- 13 A street lamp is fixed to a wall by a metal rod and a cable.

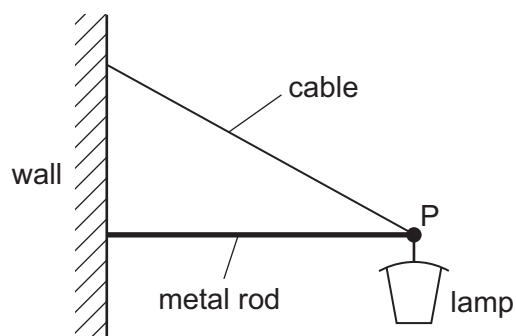

Which vector triangle could represent the forces acting at point P?

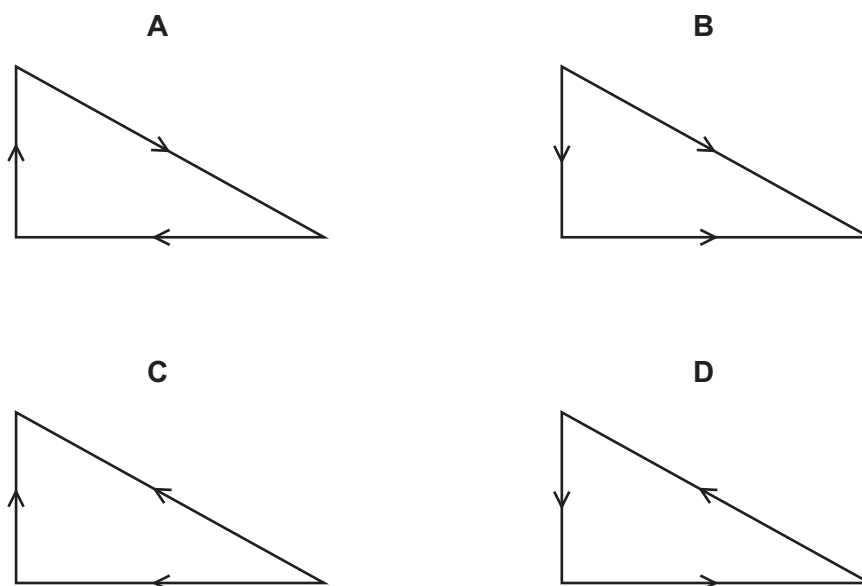

- 14 Two rigid steel beams XY and YZ are fixed at their lower ends and are hinged at Y. Each beam is inclined at  $50^\circ$  to the horizontal, as shown. A weight of  $4.0 \times 10^4 \text{ N}$  hangs from Y. The structure is in equilibrium.

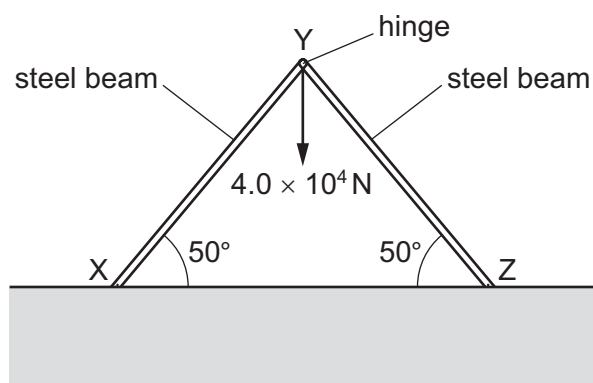

What is the force exerted by each beam on the hinge at Y?

- A**  $2.6 \times 10^4 \text{ N}$     **B**  $3.1 \times 10^4 \text{ N}$     **C**  $5.2 \times 10^4 \text{ N}$     **D**  $6.2 \times 10^4 \text{ N}$

- 15 Air is trapped inside a glass bulb which is immersed in water and attached to a U-tube containing mercury. The densities of water and mercury are  $\rho_w$  and  $\rho_m$  respectively. The surface of the water is open to the atmosphere where atmospheric pressure is  $P$ .

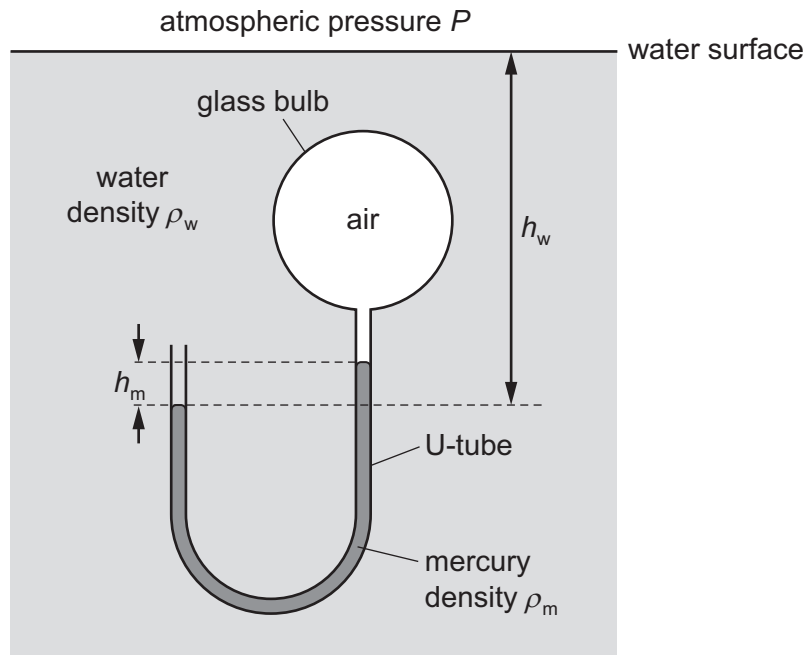

The acceleration of free fall is  $g$ .

What is the pressure of the air in the glass bulb?

- A  $P + g\rho_w h_w + g\rho_m h_m$   
 B  $P + g\rho_w h_w - g\rho_m h_m$   
 C  $g\rho_w h_w + g\rho_m h_m$   
 D  $g\rho_w h_w - g\rho_m h_m$
- 16 A ball of mass  $m$  is thrown up to height  $h$  in air with an initial velocity  $v$ , as shown.

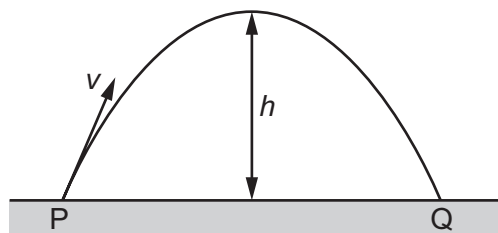

Air resistance is negligible. The acceleration of free fall is  $g$ .

What is the **total** work done by the gravitational force on the ball during its flight from P to Q?

- A zero      B  $\frac{1}{2}mv^2$       C  $mgh$       D  $2mgh$

- 17 A constant force  $F$ , acting on a car of mass  $m$ , moves the car up a slope through a distance  $s$  at constant velocity  $v$ . The angle of the slope to the horizontal is  $\alpha$ .

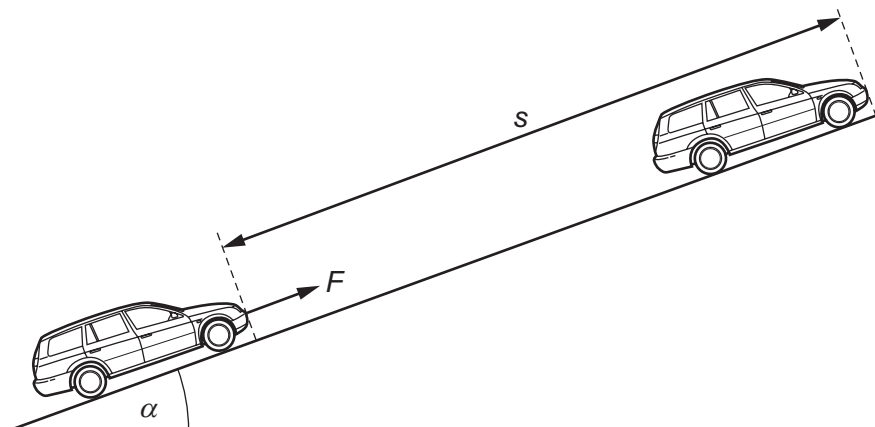

What is the ratio  $\frac{\text{gravitational potential energy gained by car}}{\text{work done by force } F}$ ?

- A  $\frac{mgs \sin \alpha}{Fv}$       B  $\frac{mv}{Fs}$       C  $\frac{mv^2}{2Fs}$       D  $\frac{mg \sin \alpha}{F}$
- 18 Car X is travelling at half the speed of car Y. Car X has twice the mass of car Y.
- Which statement is correct?
- A Car X has half the kinetic energy of car Y.  
 B Car X has one quarter of the kinetic energy of car Y.  
 C Car X has twice the kinetic energy of car Y.  
 D The two cars have the same kinetic energy.
- 19 During refuelling, a petrol car receives 50 litres of fuel in 90 seconds. The petrol has 34 MJ of energy per litre.

For an electric car to receive the same amount of energy in the same time from a 230 V supply, what is the minimum current required?

- A 2700 A      B  $8.2 \times 10^4$  A      C  $7.4 \times 10^6$  A      D  $6.6 \times 10^8$  A

- 20 A bolt is subjected to a tensile force, as shown.

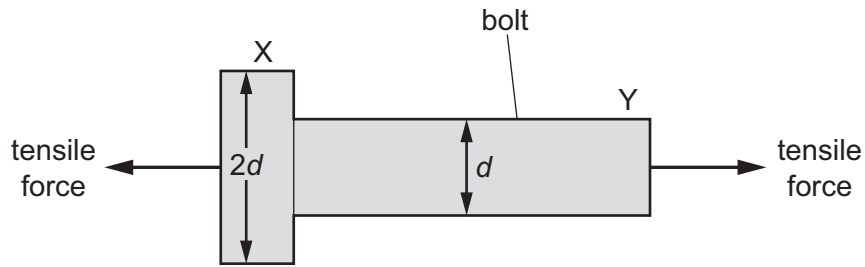

The bolt has a circular cross-section. At end X the diameter is  $2d$ . At end Y the diameter is  $d$ .

What is the ratio  $\frac{\text{stress at Y}}{\text{stress at X}}$ ?

- A 0.25      B 0.50      C 2.0      D 4.0
- 21 A rectangular block of steel supporting a very large component of a bridge has a height of 15 cm and a cross-section of  $20\text{ cm} \times 12\text{ cm}$ . It is designed to compress 1 mm when under maximum, evenly distributed, load.

The Young modulus of steel is  $2.0 \times 10^{11}\text{ N m}^{-2}$ .

What is the maximum load it can support?

- A 32 MN      B 56 GN      C 720 GN      D 32 TN

- 22 When sound travels through air, the air particles vibrate. A graph of displacement against time for a single air particle is shown.

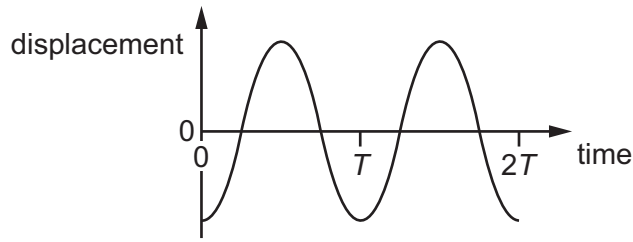

Which graph best shows how the kinetic energy of the air particle varies with time?

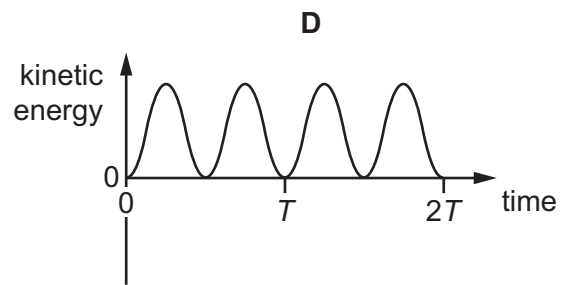
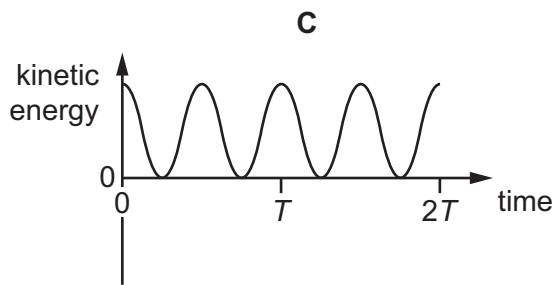
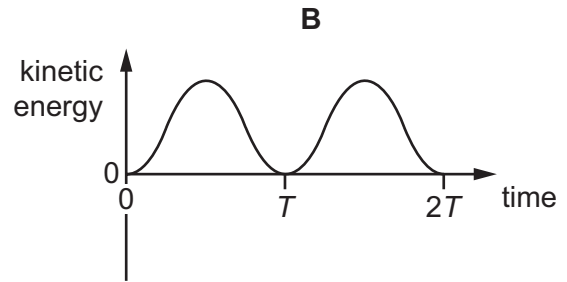
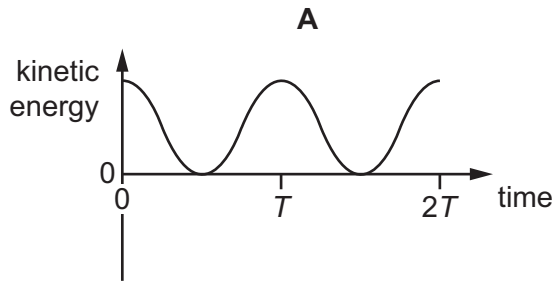

- 23 Which wave is a longitudinal wave?

- A** a light wave travelling through air
- B** a radio wave from a broadcasting station
- C** a ripple on the surface of water
- D** a sound wave travelling through air

- 24 A vibrating tuning fork is held above a glass cylinder filled to the top with water. The water level is steadily lowered. A loud sound is first heard when the water level is 83.5 cm above the bench. The next loud sound is heard when the water level is 17.1 cm above the bench.

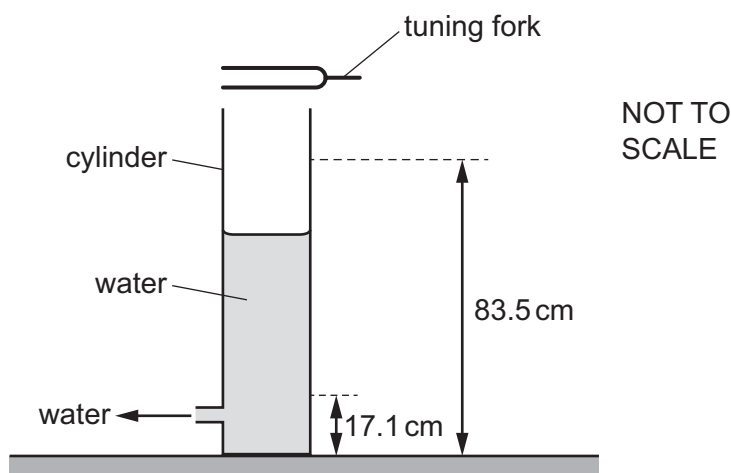

The speed of sound in air is  $340 \text{ m s}^{-1}$ .

What is the frequency of the tuning fork?

- A** 128 Hz      **B** 256 Hz      **C** 384 Hz      **D** 512 Hz
- 25 A train that is moving in a straight line along a railway track has a whistle that continuously emits sound of frequency  $f$ .

A woman standing by the side of the track hears sound of frequency  $0.85f$ .

The speed of sound in the air is  $340 \text{ m s}^{-1}$ .

What is the velocity of the train?

- A**  $51 \text{ m s}^{-1}$  away from the woman  
**B**  $51 \text{ m s}^{-1}$  towards the woman  
**C**  $60 \text{ m s}^{-1}$  away from the woman  
**D**  $60 \text{ m s}^{-1}$  towards the woman
- 26 Orange light in a vacuum has a wavelength of 600 nm.

What is the frequency of this light?

- A** 180 Hz      **B**  $5.0 \times 10^5 \text{ Hz}$       **C**  $1.8 \times 10^{11} \text{ Hz}$       **D**  $5.0 \times 10^{14} \text{ Hz}$
- 27 A stationary sound wave has a series of nodes. The distance between the first and the sixth node is 30.0 cm.

What is the wavelength of the sound wave?

- A** 5.0 cm      **B** 6.0 cm      **C** 10.0 cm      **D** 12.0 cm

28 Which diagram shows the diffraction of water waves in a ripple tank?

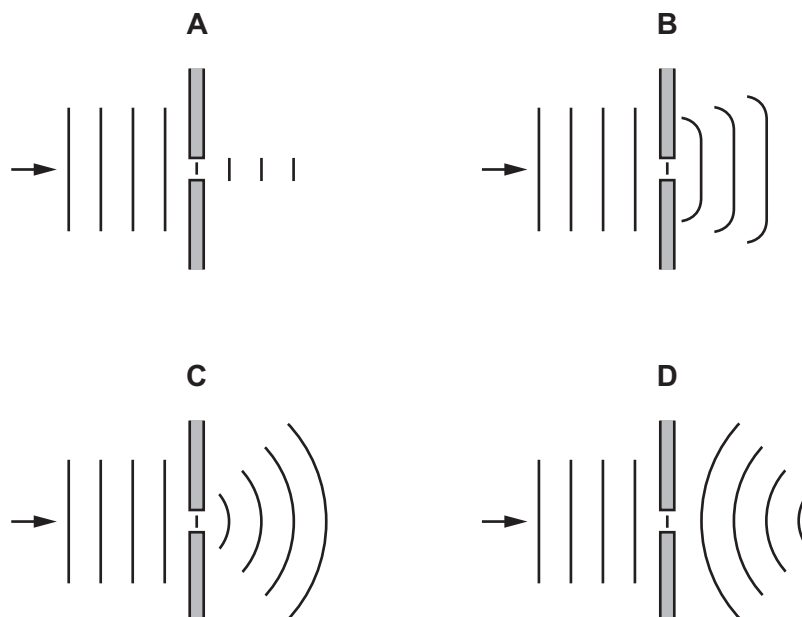

29 A hill stands between a radio transmitter and a house, as shown.



The radio transmitter cannot be seen from the house, but radio waves from the transmitter are received at the house.

Why is this?

- A** The wavelength of light is longer than the wavelength of radio waves so there is more diffraction of light over the hill.
- B** The wavelength of light is shorter than the wavelength of radio waves so there is more diffraction of light over the hill.
- C** The wavelength of radio waves is longer than the wavelength of light so there is more diffraction of radio waves over the hill.
- D** The wavelength of radio waves is shorter than the wavelength of light so there is more diffraction of radio waves over the hill.



- 30 In an experiment to demonstrate double-slit interference using light, the distance from the slits to the screen is doubled and the slit separation is halved. The wavelength of the light is kept constant.

By which factor does the separation of adjacent bright fringes change?

- A  $\frac{1}{4}$       B  $\frac{1}{2}$       C 2      D 4

- 31 The diagram shows two metal plates connected to a constant high voltage.

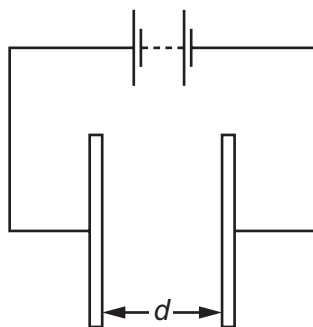

Which graph shows the variation of the electric field strength  $E$  midway between the two plates as the distance  $d$  between the two plates is increased?

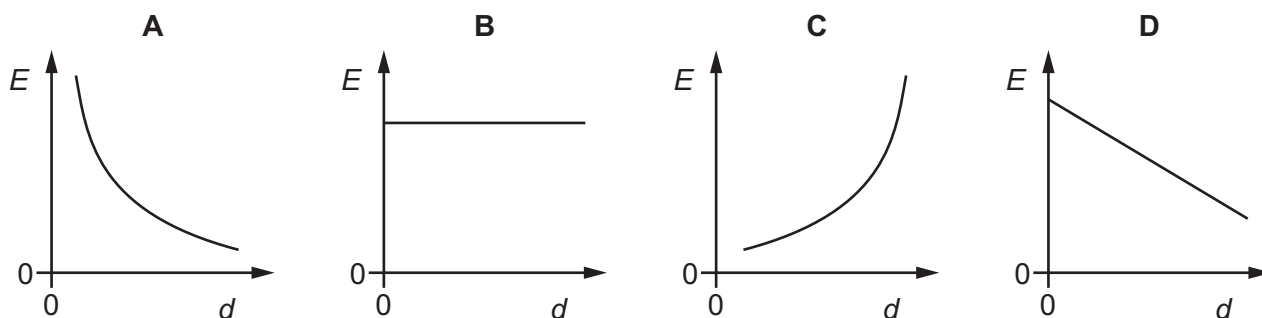

- 32 An electron moves between two points X and Y in a uniform electric field, as shown.

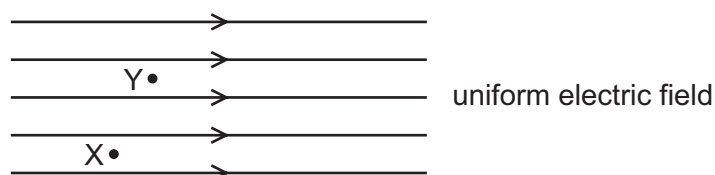

The distance between X and Y is 4.0 cm and the line XY is at an angle of  $60^\circ$  to the direction of the field.

The field exerts the only force on the electron.

The field strength is  $100 \text{ NC}^{-1}$ .

What is the change in the kinetic energy of the electron as it moves from X to Y?

- A  $-4 \text{ eV}$       B  $-2 \text{ eV}$       C  $+2 \text{ eV}$       D  $+4 \text{ eV}$

- 33 Two copper wires are joined together and carry a current, as shown.

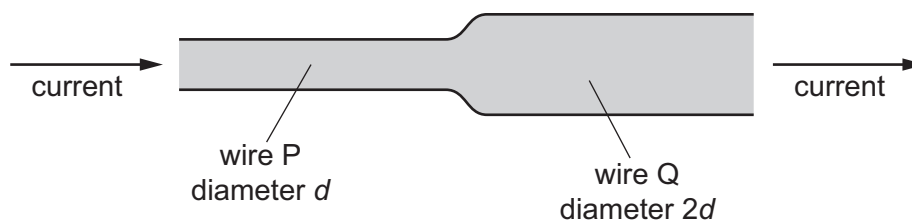

Wire P has diameter  $d$  and wire Q has diameter  $2d$ .

What is the ratio  $\frac{\text{average drift speed of the free electrons in wire P}}{\text{average drift speed of the free electrons in wire Q}}$ ?

- A  $\frac{1}{4}$                       B  $\frac{1}{2}$                       C 2                      D 4
- 34 A cell of negligible internal resistance is connected to resistors  $R_1$ ,  $R_2$  and  $R_3$ , as shown. The cell provides power to the circuit and power is dissipated in the resistors.

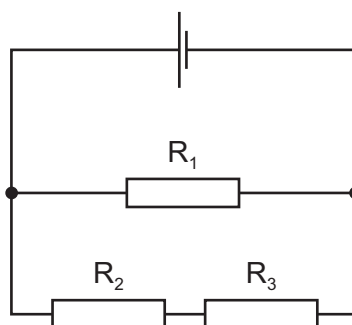

Which word equation **must** be correct?

- A power loss in  $R_1 = \text{power loss in } R_2 + \text{power loss in } R_3$   
 B power loss in  $R_2 = \text{power loss in } R_3$   
 C power output of cell = power loss in  $R_1 + \text{power loss in } R_2 + \text{power loss in } R_3$   
 D power output of cell = power loss in  $R_1$
- 35 Which graph represents a metallic conductor, where the resistance of the conductor is given by the gradient of the graph?

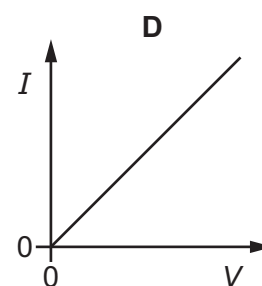
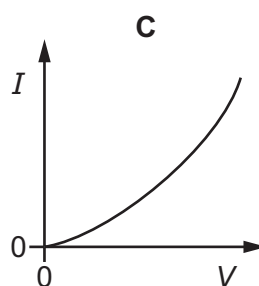
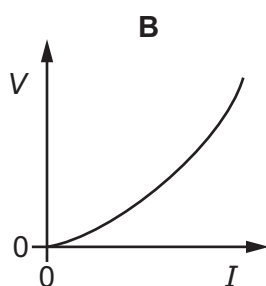
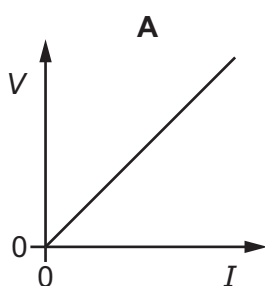

- 36 A typical mobile phone battery has an e.m.f. of 5.0V and an internal resistance of 200 m $\Omega$ .

What is the terminal p.d. of the battery when it supplies a current of 500 mA?

- A 4.8V      B 4.9V      C 5.0V      D 5.1V

- 37 The circuit shown contains a resistor S that is neither in series nor in parallel with the other resistors.

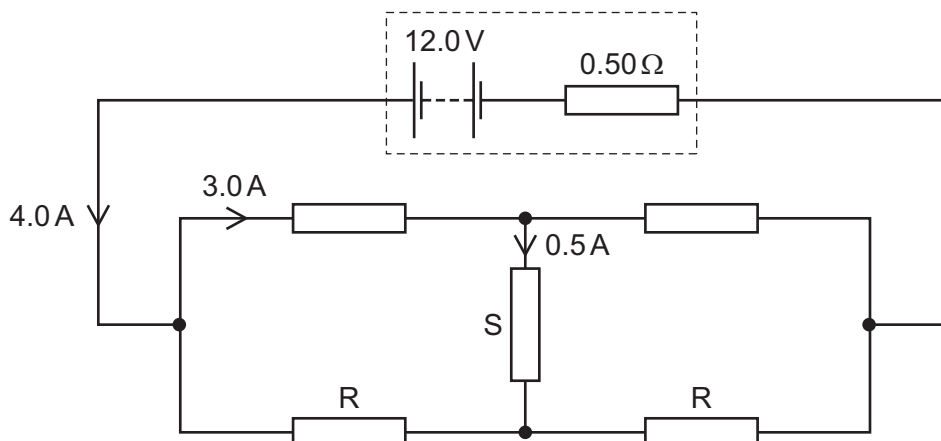

Kirchhoff's laws can be used with the data in the diagram to deduce the resistance of each of the two identical resistors labelled R.

What is the resistance of each resistor R?

- A 3.0 $\Omega$       B 4.0 $\Omega$       C 4.8 $\Omega$       D 5.0 $\Omega$

- 38 The diagram shows a potential divider connected to a 12V supply of negligible internal resistance.

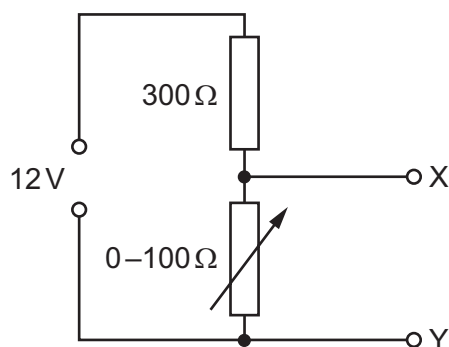

Which range of voltages can be obtained between X and Y?

- A 0 to 3V      B 0 to 4V      C 0 to 8V      D 0 to 9V

- 39 The diagram shows a sequence of radioactive decays involving three  $\alpha$ -particles and a  $\beta^-$  particle.

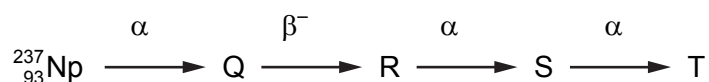

What is nuclide T?

- A  ${}_{88}^{225}\text{Ra}$       B  ${}_{88}^{231}\text{Ra}$       C  ${}_{90}^{225}\text{Th}$       D  ${}_{90}^{229}\text{Th}$
- 40 Which combination of up (u) and down (d) quarks forms a neutron?

- A u u u      B u u d      C u d d      D d d d

---

Permission to reproduce items where third-party owned material protected by copyright is included has been sought and cleared where possible. Every reasonable effort has been made by the publisher (UCLES) to trace copyright holders, but if any items requiring clearance have unwittingly been included, the publisher will be pleased to make amends at the earliest possible opportunity.

To avoid the issue of disclosure of answer-related information to candidates, all copyright acknowledgements are reproduced online in the Cambridge International Examinations Copyright Acknowledgements Booklet. This is produced for each series of examinations and is freely available to download at [www.cie.org.uk](http://www.cie.org.uk) after the live examination series.

Cambridge International Examinations is part of the Cambridge Assessment Group. Cambridge Assessment is the brand name of University of Cambridge Local Examinations Syndicate (UCLES), which is itself a department of the University of Cambridge.