

CANDIDATE
NAME

CENTRE
NUMBER

--	--	--	--	--	--

CANDIDATE
NUMBER

--	--	--	--

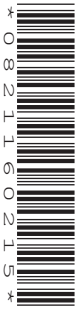

PHYSICS

9702/31

Paper 3 Advanced Practical Skills 1

October/November 2017

2 hours

Candidates answer on the Question Paper.

Additional Materials: As listed in the Confidential Instructions.

READ THESE INSTRUCTIONS FIRST

Write your Centre number, candidate number and name on all the work you hand in.

Write in dark blue or black pen.

You may use an HB pencil for any diagrams or graphs.

Do not use staples, paper clips, glue or correction fluid.

DO **NOT** WRITE IN ANY BARCODES.

Answer **both** questions.

You will be allowed to work with the apparatus for a maximum of one hour for each question.

You are expected to record all your observations as soon as these observations are made, and to plan the presentation of the records so that it is not necessary to make a fair copy of them.

You are reminded of the need for good English and clear presentation in your answers.

Electronic calculators may be used.

You may lose marks if you do not show your working or if you do not use appropriate units.

Additional answer paper and graph paper should be used only if it becomes necessary to do so.

At the end of the examination, fasten all your work securely together.

The number of marks is given in brackets [] at the end of each question or part question.

For Examiner's Use	
1	
2	
Total	

This document consists of **12** printed pages.

You may not need to use all of the materials provided.

- 1** In this experiment, you will investigate the motion of a Y-shaped pendulum.
- (a)** You have been provided with two pieces of string. The longer piece of string has a loop at each end. The shorter piece of string is attached to a bob.

Set up the apparatus as shown in Fig. 1.1.

Attach the shorter string to the middle of the longer string with a knot.

Ensure the two rods of the clamps are at the same height above the bench.

Position the stands approximately 35 cm apart.

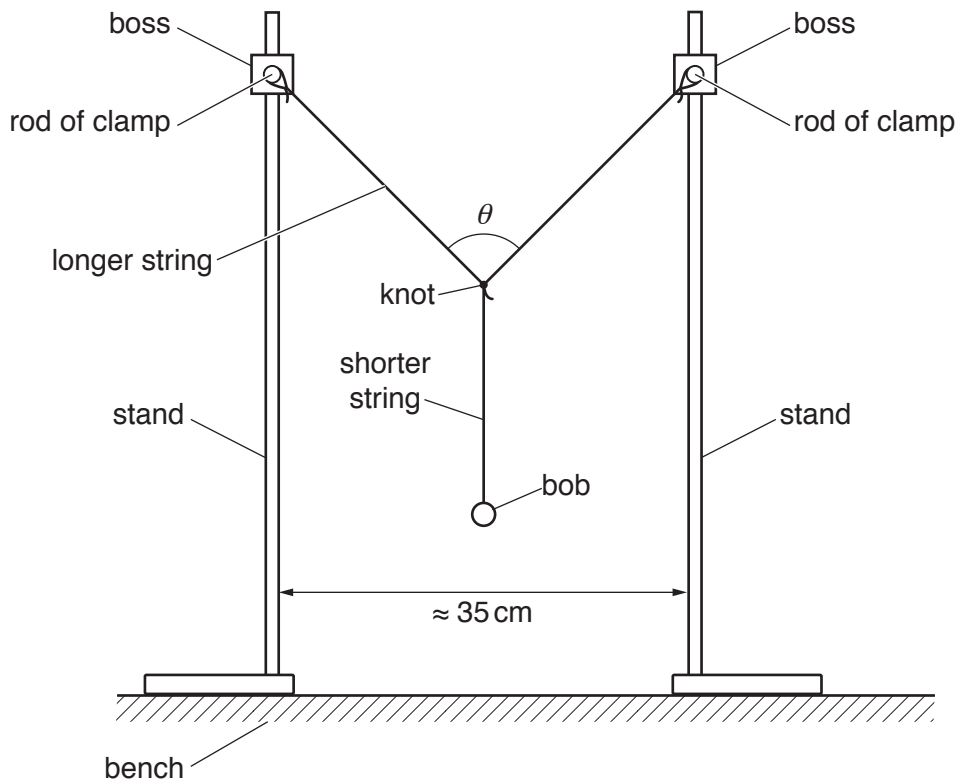

Fig. 1.1

The angle θ is the angle between the two halves of the longer string.

(b) Measure and record θ .

$\theta = \dots\dots\dots$ [1]

(c) Pull the bob a short distance towards you. Release the bob. The bob will oscillate.

Determine the period T of these oscillations.

$T = \dots\dots\dots$ [1]

- (d) Vary the distance between the stands and repeat (b) and (c) until you have six sets of values of θ and T .

Record your results in a table. Include values of $\cos\left(\frac{\theta}{2}\right)$ and T^2 in your table.

--

[10]

- (e) (i) Plot a graph of T^2 on the y -axis against $\cos\left(\frac{\theta}{2}\right)$ on the x -axis. [3]

- (ii) Draw the straight line of best fit. [1]

- (iii) Determine the gradient and y -intercept of this line.

gradient =

y -intercept =

[2]

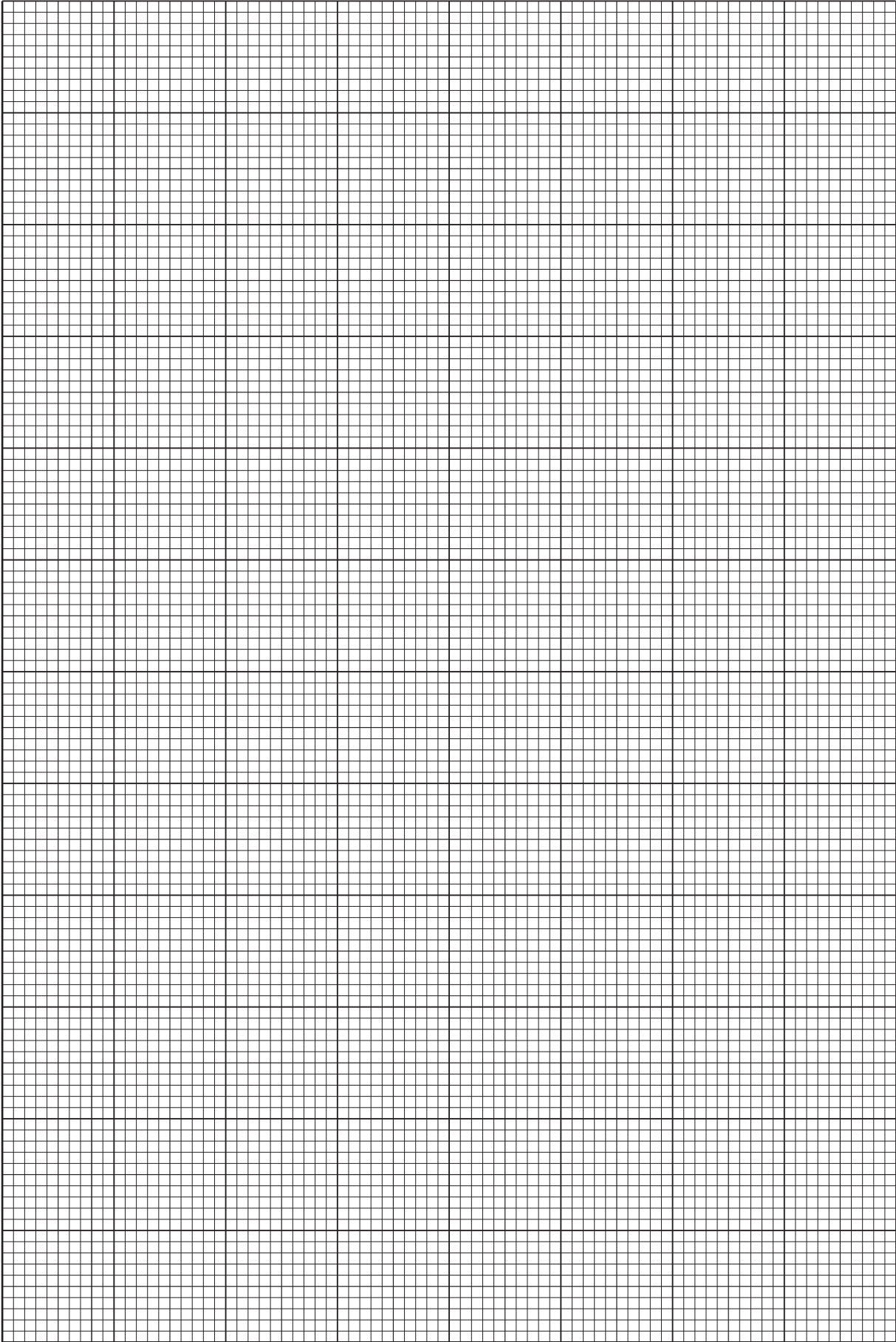

- (f) It is suggested that the quantities T and θ are related by the equation

$$T^2 = P \cos\left(\frac{\theta}{2}\right) + Q$$

where P and Q are constants.

Using your answers in (e)(iii), determine the values of P and Q .
Give appropriate units.

$P =$

$Q =$

[2]

[Total: 20]

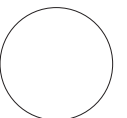

You may not need to use all of the materials provided.

- 2 In this experiment, you will investigate the appearance of a line viewed through a jar containing water.

- (a) You have been provided with an empty glass jar.

The thickness of the glass is t .

Measure and record t .

$t = \dots\dots\dots$ cm [1]

- (b) (i) The outer diameter of the glass jar is d as shown in Fig. 2.1.



Fig. 2.1

Measure and record d .

$d = \dots\dots\dots$ [1]

- (ii) Calculate the inner diameter D of the jar where

$$D = d - 2t.$$

$D = \dots\dots\dots$

- (c) (i) Add water to the jar until it is approximately three-quarters full.
 (ii) The height h of water in the jar is shown in Fig. 2.2.

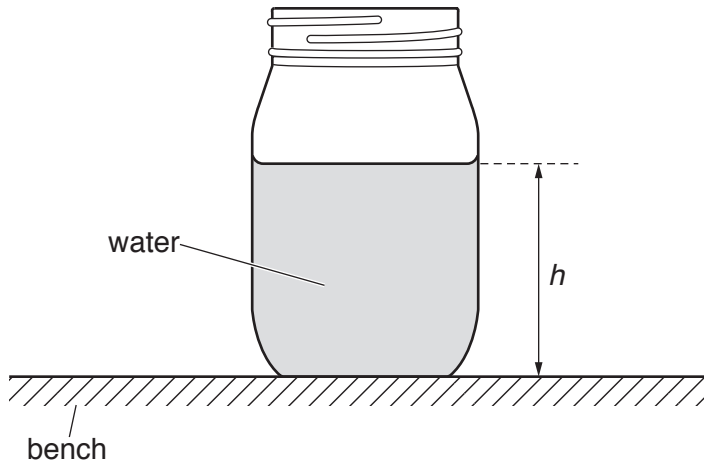

Fig. 2.2

Measure and record h .

$h = \dots\dots\dots$ [1]

- (iii) Calculate the approximate volume V of water in the jar using

$$V = \frac{\pi D^2 h}{4}$$

$V = \dots\dots\dots$ [1]

- (iv) Justify the number of significant figures that you have given for your value of V .

.....

 [1]

- (d) Draw a straight line of approximate length 25 cm in the centre of the A4 sheet of paper.

- (e) (i) Place the jar centrally on the line as shown in Fig. 2.3.

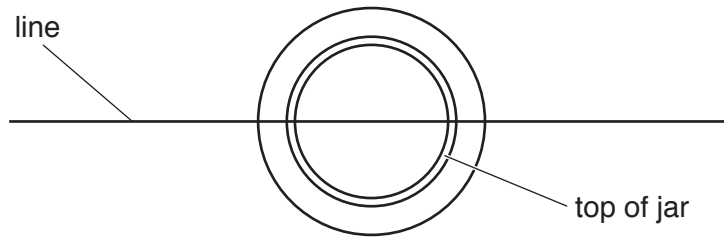

Fig. 2.3

Look down on the jar from directly above. The line should appear to pass through the centre of the jar as an unbroken straight line.

- (ii) Move your head backwards and forwards.

When viewed through the water, the line (shown dotted) appears to move as shown in Fig. 2.4.

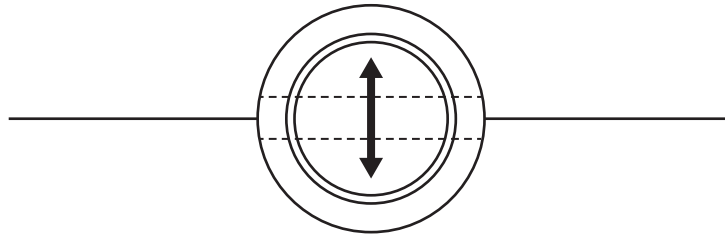

Fig. 2.4

- (iii) Place the nails on the line either side of the jar as shown in Fig. 2.5.

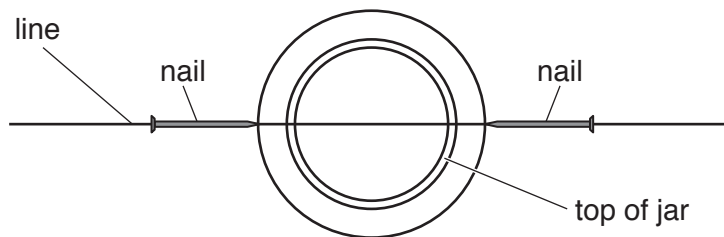

Fig. 2.5

- (iv) For a particular height of the nails, the nails and the line viewed through the water appear to move together when you move your head backwards and forwards.

Raise the nails to this height.

- (v) The distance between the surface of the water and the nails is y as shown in Fig. 2.6.

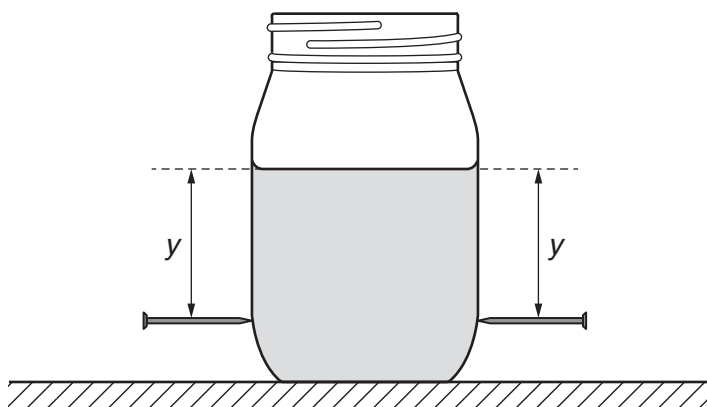

Fig. 2.6

Measure and record y .

$y = \dots\dots\dots$ [1]

- (f) Estimate the percentage uncertainty in your value of y .

percentage uncertainty = $\dots\dots\dots$ [1]

- (g) Pour water out of the jar until it is approximately half full. Repeat (c)(ii), (c)(iii) and (e).

$h = \dots\dots\dots$

$V = \dots\dots\dots$

$y = \dots\dots\dots$

[3]

(h) It is suggested that the relationship between y and V is

$$y = kV$$

where k is a constant.

(i) Using your data, calculate two values of k .

first value of $k =$

second value of $k =$

[1]

(ii) Explain whether your results support the suggested relationship.

.....
.....
.....
.....

[1]

(i) (i) Describe four sources of uncertainty or limitations of the procedure for this experiment.

- 1.
.....
- 2.
.....
- 3.
.....
- 4.
.....

[4]

(ii) Describe four improvements that could be made to this experiment. You may suggest the use of other apparatus or different procedures.

- 1.
.....
- 2.
.....
- 3.
.....
- 4.
.....

[4]

[Total: 20]

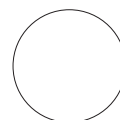

Permission to reproduce items where third-party owned material protected by copyright is included has been sought and cleared where possible. Every reasonable effort has been made by the publisher (UCLES) to trace copyright holders, but if any items requiring clearance have unwittingly been included, the publisher will be pleased to make amends at the earliest possible opportunity.

To avoid the issue of disclosure of answer-related information to candidates, all copyright acknowledgements are reproduced online in the Cambridge International Examinations Copyright Acknowledgements Booklet. This is produced for each series of examinations and is freely available to download at www.cie.org.uk after the live examination series.

Cambridge International Examinations is part of the Cambridge Assessment Group. Cambridge Assessment is the brand name of University of Cambridge Local Examinations Syndicate (UCLES), which is itself a department of the University of Cambridge.