

**PHYSICS**

**0625/51**

Paper 5 Practical Test

**October/November 2017**

CONFIDENTIAL INSTRUCTIONS

**Great care should be taken to ensure that any confidential information given does not reach the candidates either directly or indirectly.**

If you have any queries regarding these Confidential Instructions, please contact Cambridge stating the Centre number, the nature of the query and the syllabus number quoted above.

email [info@cie.org.uk](mailto:info@cie.org.uk)

phone +44 1223 553554

fax +44 1223 553558



The syllabus is approved for use in England, Wales and Northern Ireland as a Cambridge International Level 1/Level 2 Certificate.

This document consists of **7** printed pages and **1** blank page.

### Instructions for preparing apparatus

The Supervisor is **not** allowed to consult the Question Paper before the examination. This teacher should, as part of the preparation of the examination requirements, test the apparatus in order to ensure that it is satisfactory.

The Supervisor is asked to give (and attach to the Supervisor's Report printed on pages 7 and 8) a *brief* description of the apparatus supplied, mentioning any points that are likely to be of importance to the Examiner in marking the answers. The Supervisor should also report any assistance given to candidates. All reports should be signed by the Supervisor.

In addition to the usual equipment of a physics laboratory, each candidate will require the apparatus specified in these Confidential Instructions. If a candidate breaks any of the apparatus, or loses any of the material supplied, the matter should be rectified and a note made in the Supervisor's Report.

### Number of sets of apparatus

As a *minimum*, the number of sets of apparatus provided should be  $N/3$ , where  $N$  is the number of candidates (per session). A few spare sets should, preferably, be available to avoid any candidate being delayed when moving to another question.

The order in which a given candidate attempts the four questions is immaterial. It is suggested that candidates spend **about 20 minutes on each of questions 1 to 3 and about 15 minutes on question 4.**

### Assistance to candidates

The purpose of the Physics Practical Test is to find out whether the candidates can carry out simple practical work themselves. The Examiners are aware that candidates may sometimes be unable to show their practical ability through failure to understand some point in the theory of the experiment. If an Examiner were present in the laboratory, he/she would be willing to give a hint to enable such a candidate to get on with an experiment. In order to overcome this difficulty, the Supervisor is asked to cooperate with the Examiners to the extent of being ready to give (or allow the physics teacher to give) a hint to a candidate who is unable to proceed.

The following regulations must be strictly adhered to.

- (i) No hint may be announced to the candidates as a whole.
- (ii) A candidate who is unable to proceed and requires assistance must come up to the Supervisor and state the difficulty. Candidates should be told that the Examiners will be informed of any assistance given in this way.
- (iii) A report must be made of any assistance given to the candidate, with the name and candidate number of the candidate.

It is suggested that the following announcement be made to the candidates.

'The Examiners do not want you to waste time through inability to get on with an experiment. Any candidate, therefore, who is unable to get on with the experiment after spending five minutes at it may come to me and ask for help. I shall report to the Examiners any help given in this way, and some marks may be lost for the help given. You may ask me for additional apparatus which you think would improve the accuracy of your experiments, and you should say, on your script, how you use any such apparatus supplied.'

**Question 1****Items to be supplied by the Centre (per set of apparatus, unless otherwise specified)**

- (i) Metre rule with a mm scale. See note 1.
- (ii) Triangular block to act as a pivot for the metre rule. This block is to stand on the bench.
- (iii) A 200g mass, labelled **P**. See notes 2 and 3.
- (iv) Masses of 100g, 200g, 300g, 400g and 500g labelled **1.0N**, **2.0N**, **3.0N**, **4.0N** and **5.0N**, respectively. See note 2.

**Notes**

1. If the metre rule has two scales in opposite directions, one scale must be taped over.
2. Any suitable masses that can rest on the metre rule can be used.
3. The value of the mass of **P** must **not** be visible to the candidates.

**Action at changeover**

Remove the masses from the rule.

Remove the metre rule from the pivot.

Check that the apparatus is ready for the next candidate.

## Question 2

### Items to be supplied by the Centre (per set of apparatus, unless otherwise specified)

- (i) Power supply of approximately 1.5V–3V. Where candidates are provided with a power supply with a variable output voltage, the voltage must be set by the Supervisor and fixed (e.g. taped). See note 2.
- (ii) Three resistors of nominal value  $4.7\ \Omega$  with a power rating of at least 2W. See note 3.
- (iii) Switch. The switch may be an integral part of the power supply.
- (iv) Ammeter capable of reading up to 1.00A, with a resolution of at least 0.05A. See note 4.
- (v) Voltmeter capable of measuring the supply p.d. with a resolution of at least 0.1 V. See note 4.
- (vi) Sufficient connecting leads to construct the circuit shown in Fig. 2.1, with two additional leads.

### Notes

1. The circuit is to be connected by the Supervisor as shown in Fig. 2.1.

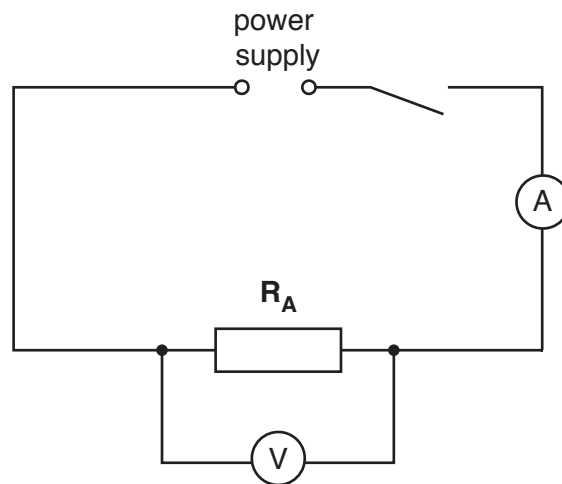

Fig. 2.1

2. If cells are to be used, they must remain adequately charged throughout the examination. Spare cells must be available.
3. The resistors must be labelled  $R_A$ ,  $R_B$  and  $R_C$ . The values of resistance must **not** be visible to the candidates. The resistors must have suitable terminals so that candidates are able easily and quickly to rearrange the circuit.
4. Either analogue or digital meters are suitable. Any variable settings must be set by the Supervisor and fixed (e.g. taped). Spare meters should be available.
5. Spare leads should be available.

### Action at changeover

Set up the circuit so that it is arranged as shown in Fig. 2.1.  
Check that the circuit works. Switch off.

### Question 3

#### Items to be supplied by the Centre (per set of apparatus, unless otherwise specified)

- (i) Converging lens, focal length approximately 15 cm, with a suitable holder.
- (ii) Illuminated object with a triangular hole of height 1.5 cm (see Fig. 3.1). The hole is to be covered with thin, translucent paper (e.g. tracing paper). See note 2.
- (iii) Metre rule with a mm scale.
- (iv) Screen. A white sheet of stiff card approximately 15 cm × 15 cm, fixed to a wooden support is suitable. See Fig. 3.2.
- (v) A 12 V, 24 W lamp and holder. A 12 V power supply. Spare lamps should be available.

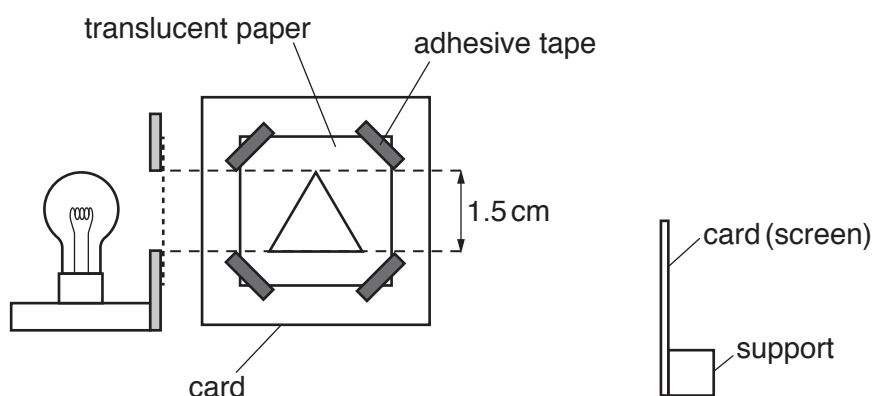

Fig. 3.1

Fig. 3.2

#### Notes

1. The lamp for the illuminated object should be a low voltage lamp, approximately 24 W or higher power (a car headlamp bulb is suitable), with a suitable power supply.
2. The centre of the hole which forms the object, the lamp filament and the centre of the lens in its holder are all to be at the same height above the bench.
3. The apparatus is to be situated away from direct sunlight.

#### Action at changeover

Check that the apparatus is ready for the next candidate.

### Question 4

No apparatus is required for this question.

**BLANK PAGE**

---

Permission to reproduce items where third-party owned material protected by copyright is included has been sought and cleared where possible. Every reasonable effort has been made by the publisher (UCLES) to trace copyright holders, but if any items requiring clearance have unwittingly been included, the publisher will be pleased to make amends at the earliest possible opportunity.

To avoid the issue of disclosure of answer-related information to candidates, all copyright acknowledgements are reproduced online in the Cambridge International Examinations Copyright Acknowledgements Booklet. This is produced for each series of examinations and is freely available to download at [www.cie.org.uk](http://www.cie.org.uk) after the live examination series.

Cambridge International Examinations is part of the Cambridge Assessment Group. Cambridge Assessment is the brand name of University of Cambridge Local Examinations Syndicate (UCLES), which is itself a department of the University of Cambridge.

**This form must be completed and returned with the scripts.**

### **SUPERVISOR'S REPORT**

#### *General*

The Supervisor is invited to give details of any difficulties experienced by particular candidates giving their names and candidate numbers. These should include reference to:

- (a) difficulties due to faulty apparatus;
- (b) accidents to apparatus or materials;
- (c) any other information that is likely to assist the Examiner, especially if this cannot be discovered in the scripts;
- (d) any help given to a candidate.

#### *Information required*

A plan of workbenches, giving details by candidate number of the places occupied by the candidates for each experiment for each session, must be enclosed with the scripts.

*Information required (cont.)*

A list by name and candidate number of candidates requiring help, with details of the help provided.

CENTRE NO. ....

NAME OF CENTRE .....

*Declaration (to be signed by the Supervisor).*

The preparation of the practical examination has been carried out so as to maintain fully the security of the examination.

SIGNED .....  
Supervisor