



Cambridge International Examinations
Cambridge International General Certificate of Secondary Education

BIOLOGY

0610/23

Paper 2 Multiple Choice (Extended)

October/November 2017

45 minutes

Additional Materials: Multiple Choice Answer Sheet
Soft clean eraser
Soft pencil (type B or HB is recommended)

* 0 2 8 8 6 8 5 3 2 9 *

READ THESE INSTRUCTIONS FIRST

Write in soft pencil.

Do not use staples, paper clips, glue or correction fluid.

Write your name, Centre number and candidate number on the Answer Sheet in the spaces provided unless this has been done for you.

DO NOT WRITE IN ANY BARCODES.

There are **forty** questions on this paper. Answer **all** questions. For each question there are four possible answers **A, B, C** and **D**.

Choose the **one** you consider correct and record your choice in **soft pencil** on the separate Answer Sheet.

Read the instructions on the Answer Sheet very carefully.

Each correct answer will score one mark. A mark will not be deducted for a wrong answer.

Any rough working should be done in this booklet.

Electronic calculators may be used.

The syllabus is approved for use in England, Wales and Northern Ireland as a Cambridge International Level 1/Level 2 Certificate.

This document consists of **17** printed pages and **3** blank pages.

- 1 The plant *Mimosa pudica* has leaves that fold in when touched.

This demonstrates movement and which other characteristic?

- A excretion
- B growth
- C nutrition
- D sensitivity

- 2 The diagram shows a section of DNA from a chimpanzee.

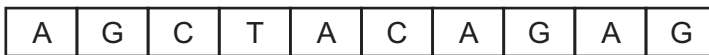

Which diagram shows a section of DNA from the organism that is most closely related to the chimpanzee?



3 The diagrams show structures associated with a leaf.

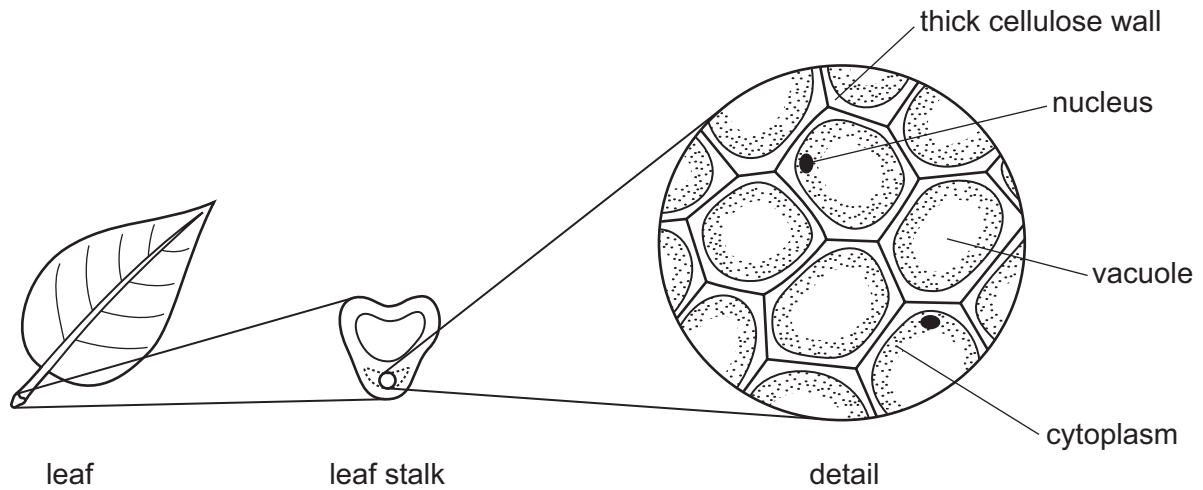

What is the level of organisation of the part shown in detail?

- A cell
- B organ
- C organ system
- D tissue

4 The diagram shows a pollen grain of a rice plant. The size of the image is 40 mm

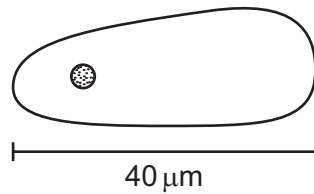

The actual length of the pollen grain is 40 μm.

By how many times has the diagram been magnified?

- A ×1
- B ×10
- C ×100
- D ×1000

- 5 Three equally sized pieces of potato were put into different concentrations of sucrose solution. One piece of potato was put into distilled water.

The concentrations of sucrose solution were 0.2 g dm^{-3} , 0.4 g dm^{-3} and 0.6 g dm^{-3} .

The graph shows the change in mass of the potato pieces over a period of 60 minutes.

Which piece of potato was put into distilled water?

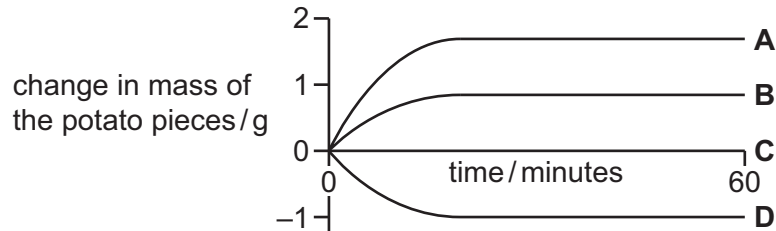

- 6 A red blood cell and a palisade mesophyll cell are placed in a solution which has a higher water potential than the cells.

What will happen to each cell?

	red blood cell	palisade mesophyll cell
A	bursts	bursts
B	bursts	gains mass
C	loses mass	gains mass
D	loses mass	loses mass

- 7 The diagram shows an evolutionary tree based on a computer-generated study of different sea mammals.

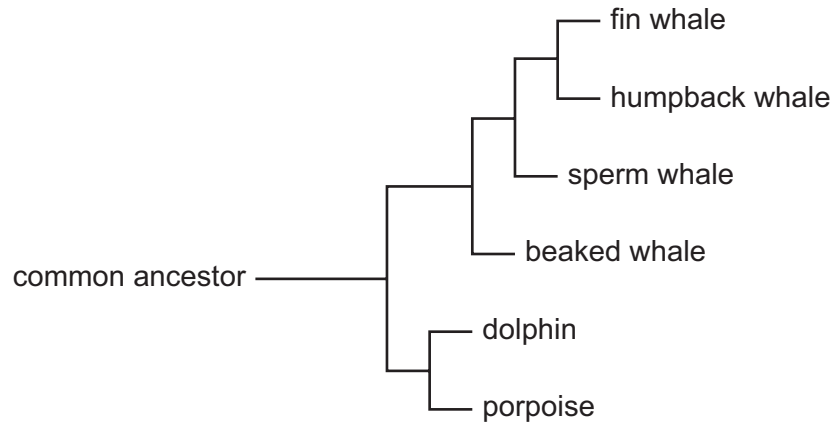

According to this evolutionary tree, which whale has DNA base sequences that are **least** shared with the other whales?

- A beaked whale
 - B fin whale
 - C humpback whale
 - D sperm whale
- 8 What is the colour change shown by Benedict's solution when heated with a reducing sugar?
- A blue to purple
 - B blue to red
 - C brown to blue-black
 - D red to yellow

9 Into which part of the alimentary canal is the enzyme that digests starch secreted?

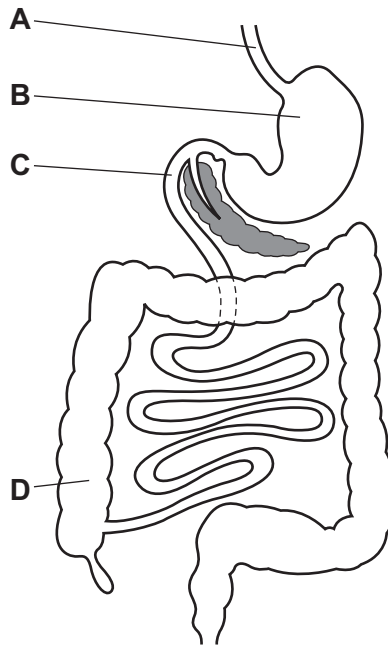

10 The diagram shows an enzyme with its substrate and product molecules.

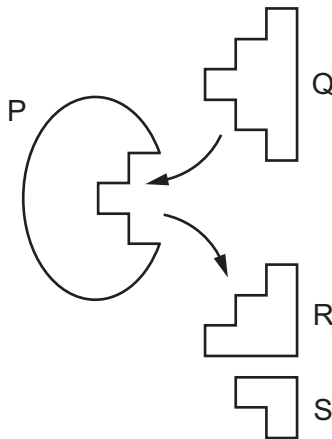

Which form an enzyme-substrate complex?

- A** P and Q **B** Q and R **C** R and S **D** S and P

- 11 The diagram shows the apparatus at the beginning of an investigation into temperature change during the germination of seeds. The temperature at the start of the investigation was 25 °C in both flasks.

After two days the temperature in flask 1 is 25 °C. The temperature in flask 2 is 28 °C.

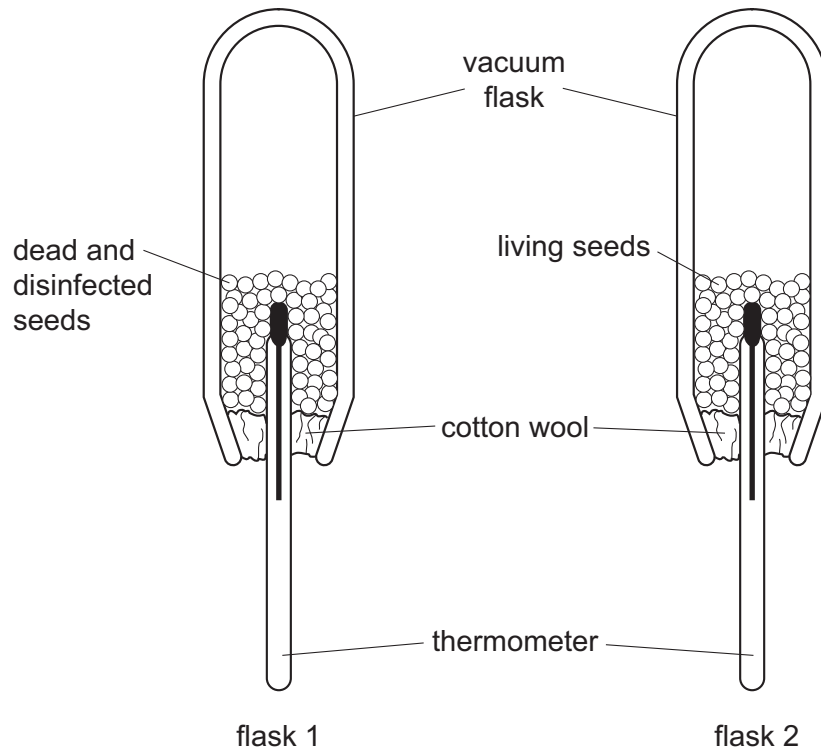

Which characteristic of living organisms is shown in this experiment?

- A excretion
 - B growth
 - C reproduction
 - D respiration
- 12 What must be increased in the diet of a person suffering from constipation?
- A fats
 - B fibre
 - C iron
 - D protein

13 Which substrate, enzyme and product are correctly named?

	substrate	enzyme	product
A	amino acids	trypsin	protein
B	amylase	maltose	glucose
C	lipase	lipid	fatty acids and glycerol
D	maltose	maltase	glucose

14 The diagram shows the human alimentary canal, with a string marked in metres beside it.

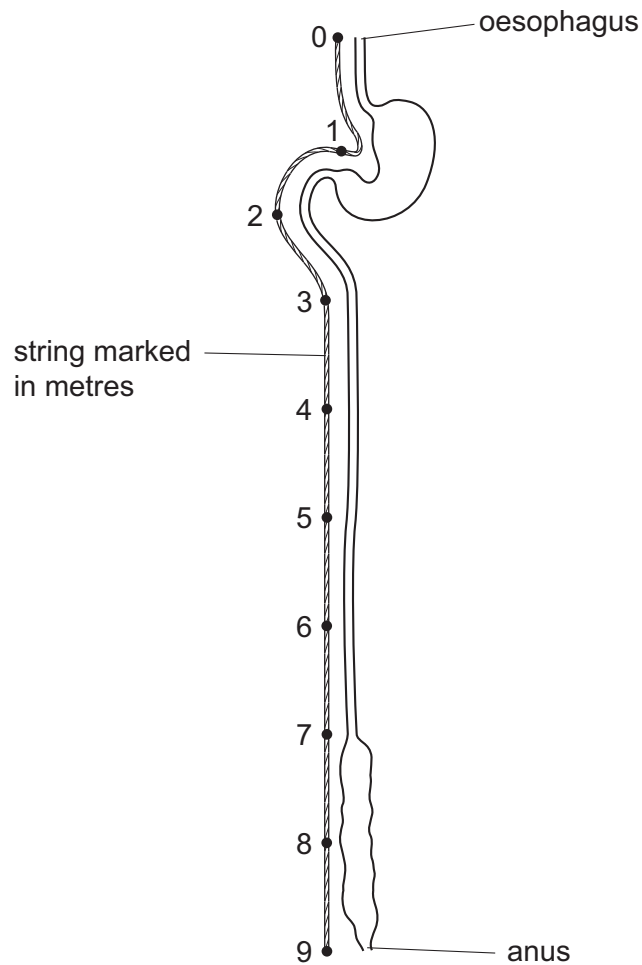

How long is the small intestine?

- A** 2m **B** 6m **C** 8m **D** 9m

15 What is **not** a use of water by plants?

- A acting as a solvent
- B cooling the plant
- C dissolving cellulose cell walls
- D raw material in photosynthesis

16 What is a description of transpiration?

- A exchange of gases between the leaf and the atmosphere
- B loss of water vapour from the leaves and stems of a plant
- C movement of water from the roots to the leaves
- D movement of water through the cells of the leaf

17 The diagram represents the circulatory system of a mammal.

In which chamber of the heart are the muscle walls thickest?

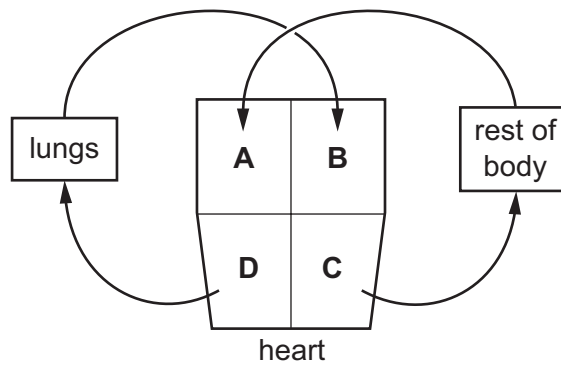

18 The diagram shows a cross-section through a human blood vessel.

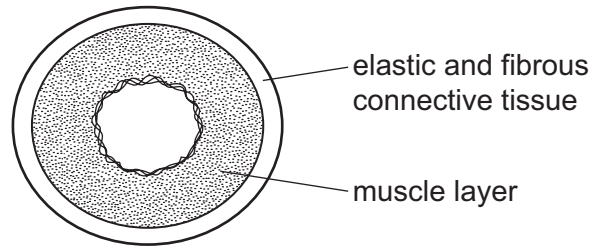

Which type of blood vessel does the diagram show?

- A an artery
 - B a capillary
 - C a vein
 - D a ventricle
- 19 What can be passed from one person to another during blood transfusion?
- A cholera
 - B chronic obstructive pulmonary disease (COPD)
 - C HIV
 - D scurvy
- 20 The table shows some of the changes that occur during breathing.

	from contracted to relaxed	from relaxed to contracted
diaphragm	P	X
external intercostals	Q	Y
internal intercostals	R	Z

Which changes occur to cause inspiration?

- A P, Q and Z
- B X, Q and R
- C X, Y and R
- D X, Y and Z

21 In an experiment to investigate anaerobic respiration, two bottles are set up in a warm room, as shown.

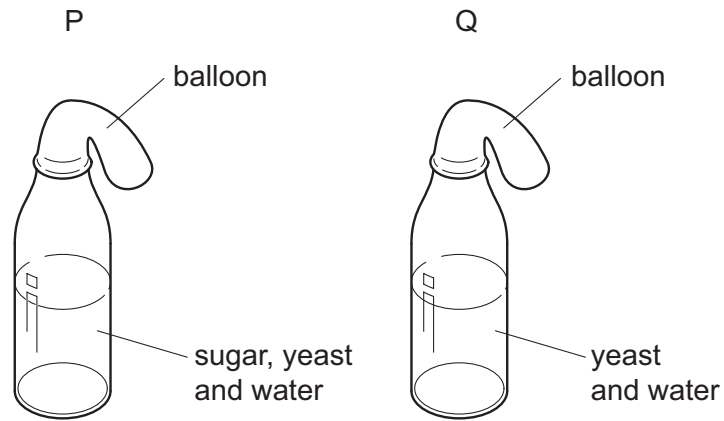

What would happen to each balloon after one day?

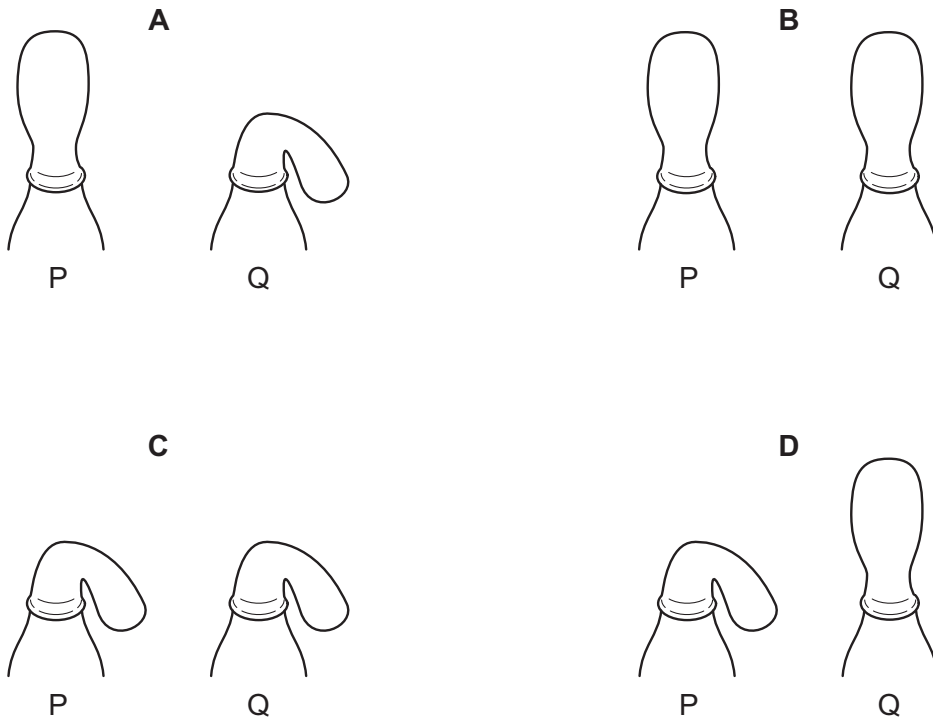

22 Two pieces of an aquatic plant were placed into two different test-tubes, P and Q.

Each test-tube contained hydrogencarbonate indicator and was sealed and kept at 20 °C.

Test-tube P was kept in the light and test-tube Q was kept in the dark.

The table shows the effect of carbon dioxide on the colour of the hydrogencarbonate indicator.

less carbon dioxide	more carbon dioxide
dark red	orange

What would the colour of the indicator be after 12 hours?

	P	Q
A	dark red	orange
B	dark red	dark red
C	orange	dark red
D	orange	orange

23 What is the most important function of sweating?

- A** to remove excess heat from the body
- B** to remove excess salts from the body
- C** to remove excess urea from the body
- D** to remove excess water from the body

24 A student begins to lose control of her bicycle while travelling down a hill at speed.

The concentration of which substance will begin to increase rapidly in her blood?

- A** adrenaline
- B** insulin
- C** oestrogen
- D** testosterone

25 The diagram shows a person sweating in hot weather.



What part is played by sweat glands during the process of sweating?

- A effector
- B receptor
- C sense organ
- D stimulus

26 The diagram shows a synapse in a reflex arc.

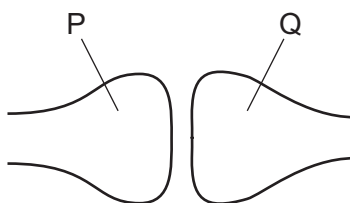

What are the identities of the two neurones and in which direction does the neurotransmitter pass?

	neurone P	neurone Q	direction of passage of neurotransmitter
A	motor	relay	P → Q
B	motor	sensory	P → Q
C	relay	motor	Q → P
D	relay	sensory	Q → P

27 Which process occurring at a synapse is prevented by the presence of heroin?

- A the binding of a neurotransmitter with receptors
- B the diffusion of a neurotransmitter across the gap
- C the formation of a neurotransmitter
- D the stimulation of vesicles by an impulse

28 The diagram shows half a flower.

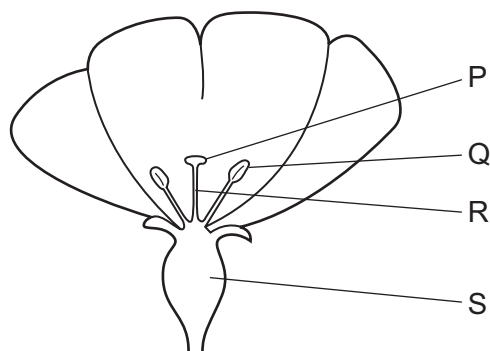

After pollination, where would pollen grains be found?

- A** P and Q **B** Q and R **C** R and S **D** S and P

29 Which environmental factor is **not** always a requirement for seed germination?

- A** light
B oxygen
C suitable temperature
D water

30 A pure-breeding white rat was crossed with a pure-breeding black rat. All their offspring were black.

One of the offspring was bred with a pure-breeding white rat.

What is the most likely percentage of black rats in the offspring?

- A** 25 **B** 50 **C** 75 **D** 100

31 An organism is heterozygous for a gene with the alleles T and t.

Which diagram represents a diploid cell from this organism?

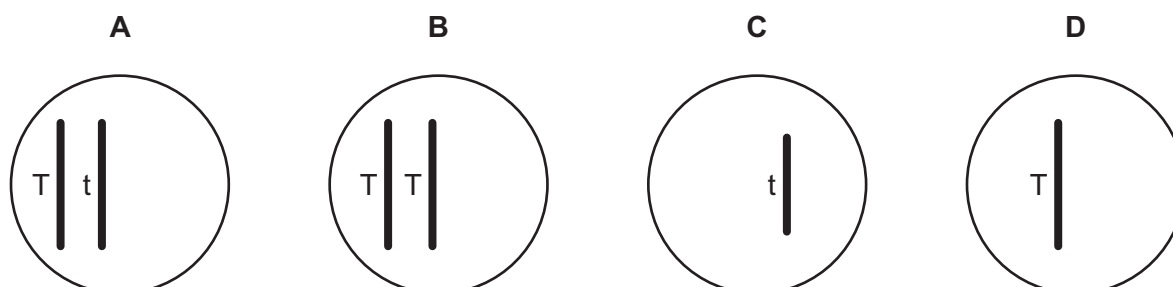

32 Red-green colour blindness is a sex-linked characteristic caused by a recessive allele.

Which prediction can be made about the children of a woman who is colour-blind and a man with normal vision?

- A Boys will be colour-blind, girls will have a 50% chance of being colour-blind.
- B Boys will be colour-blind, girls will have normal vision.
- C Girls will be colour-blind, boys will have a 50% chance of being colour-blind.
- D Girls will be colour-blind, boys will have normal vision.

33 The diagram shows a vertical section through a leaf.

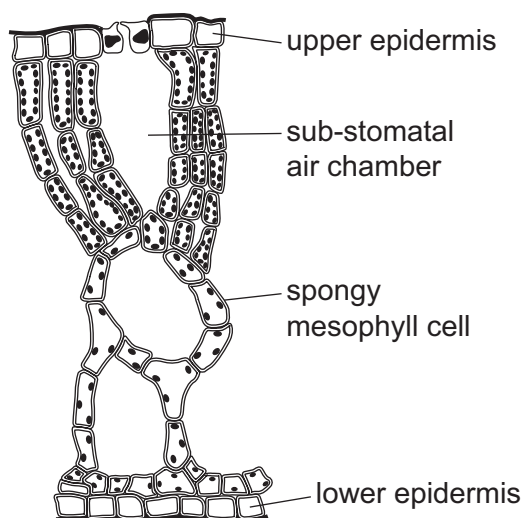

Which diagram shows the plant that the leaf was taken from?

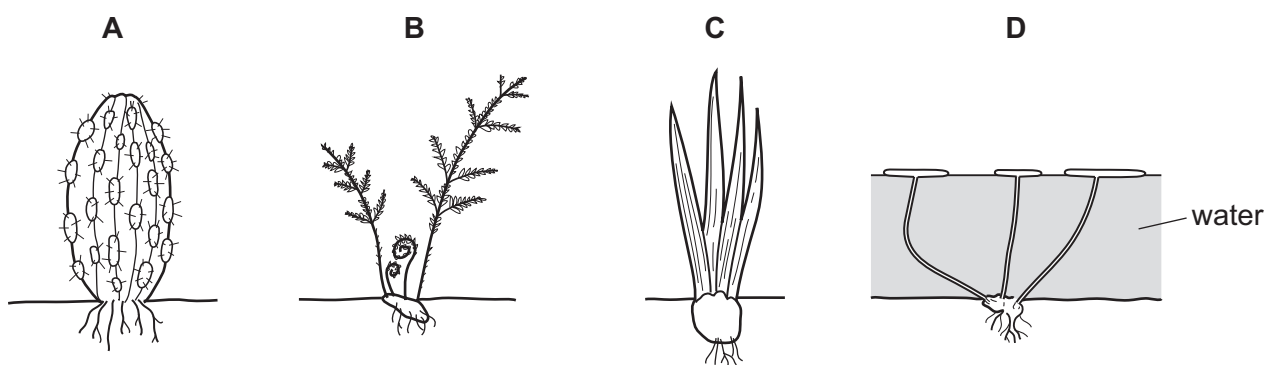

34 What is a mutation?

- A a change in appearance
- B a change in a gene
- C a change in behaviour
- D a change in the environment

- 35 The biomass at each trophic level in an ecosystem is measured. The results are shown in the table.

Which trophic level contains herbivores?

trophic level	mass / g m ⁻³
A	0.1
B	0.6
C	1.2
D	17.9

- 36 The diagram shows a food web.

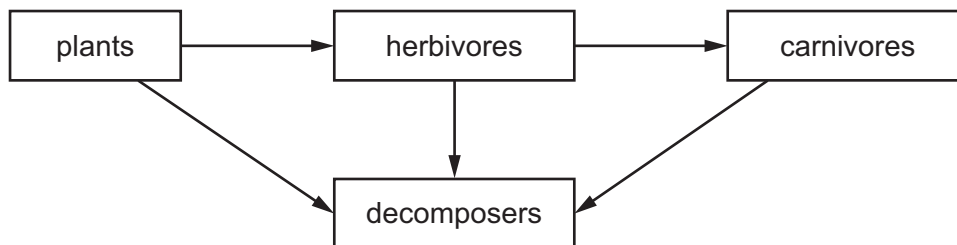

What do the arrows represent?

- A** the absorption of oxygen
 - B** the absorption of water
 - C** the flow of energy
 - D** the release of carbon dioxide
- 37 Ligase enzymes are used in genetic engineering to
- A** cut open plasmid DNA.
 - B** insert plasmids into bacteria.
 - C** isolate the DNA making up a human gene.
 - D** join human DNA to plasmid DNA.
- 38 With which kingdoms do bacteria share the same genetic code?
- A** animal, plant, fungus and protist
 - B** animal, plant and fungus only
 - C** animal and plant only
 - D** animal only

39 What is a direct result of deforestation?

- A decreased leaching of mineral salts
- B increased loss of soil
- C increased production of methane
- D increased recycling of important minerals

40 The table shows the ability of three species of fish and their eggs to survive in water at different pH levels.

If the eggs do not survive offspring cannot be produced.

	pH						key
	6.5	6.0	5.5	5.0	4.5	4.0	
trout	✓	✓	✓	✓	✓	✗	✓ = survive ✗ = do not survive
sea bass	✓	✓	✓	✗	✗	✗	
perch	✓	✓	✓	✓	✗	✗	
fish eggs	✓	✓	✓	✗	✗	✗	

A lake at pH 6.0 contains breeding populations of all three fish.

If acid rain causes the pH to fall to 5.0, which outcome would be likely to occur?

- A Trout and perch will survive and produce offspring.
- B Trout and perch will survive but only perch will produce offspring.
- C Trout and perch will survive but produce no offspring.
- D Trout, sea bass and perch will survive but produce no offspring.

BLANK PAGE

Permission to reproduce items where third-party owned material protected by copyright is included has been sought and cleared where possible. Every reasonable effort has been made by the publisher (UCLES) to trace copyright holders, but if any items requiring clearance have unwittingly been included, the publisher will be pleased to make amends at the earliest possible opportunity.

To avoid the issue of disclosure of answer-related information to candidates, all copyright acknowledgements are reproduced online in the Cambridge International Examinations Copyright Acknowledgements Booklet. This is produced for each series of examinations and is freely available to download at www.cie.org.uk after the live examination series.

Cambridge International Examinations is part of the Cambridge Assessment Group. Cambridge Assessment is the brand name of University of Cambridge Local Examinations Syndicate (UCLES), which is itself a department of the University of Cambridge.