

CANDIDATE  
NAME

CENTRE  
NUMBER

--	--	--	--	--

CANDIDATE  
NUMBER

--	--	--	--



**PHYSICS**

Paper 6 Alternative to Practical

**0625/62**

**February/March 2017**

**1 hour**

Candidates answer on the Question Paper.

No Additional Materials are required.

**READ THESE INSTRUCTIONS FIRST**

Write your Centre number, candidate number and name on all the work you hand in.

Write in dark blue or black pen.

You may use an HB pencil for any diagrams or graphs.

Do not use staples, paper clips, glue or correction fluid.

**DO NOT WRITE IN ANY BARCODES.**

Answer **all** questions.

Electronic calculators may be used.

You may lose marks if you do not show your working or if you do not use appropriate units.

At the end of the examination, fasten all your work securely together.

The number of marks is given in brackets [ ] at the end of each question or part question.

- 1 Some students are investigating how the surrounding temperature affects the rate at which water cools.

They are using the apparatus shown in Fig. 1.1.

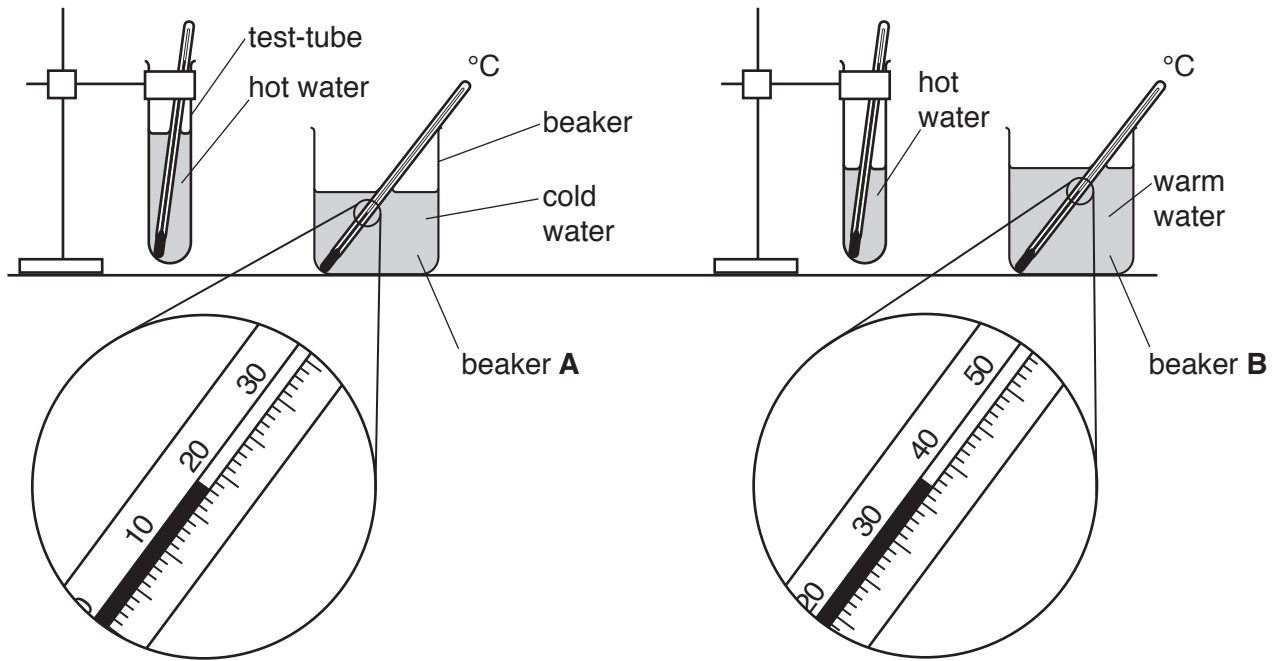

Fig. 1.1

(a) Using Fig. 1.1

- record the temperature  $\theta_A$  of the cold water in beaker **A**,

$\theta_A = \dots\dots\dots$

- record the temperature  $\theta_B$  of the warm water in beaker **B**.

$\theta_B = \dots\dots\dots$

[1]

(b) The test-tubes of hot water are placed into beakers **A** and **B**.

The students record the temperatures  $\theta$  of the water in the test-tubes every 30s. Their readings are shown in Table 1.1.

Complete the units and the time column in Table 1.1.

**Table 1.1**

time	tube in beaker <b>A</b> with cold water	tube in beaker <b>B</b> with warm water
$t/$	$\theta/$	$\theta/$
0	80.5	81.0
	52.5	64.5
	42.0	55.0
	36.0	50.5
	32.5	48.0
	30.5	46.5
	29.0	45.5

[2]

(c) Describe **two** precautions that you would take, before reading the thermometer, to ensure that the temperature readings are as accurate as possible in the experiment.

1. ....  
.....
2. ....  
.....

[2]

(d) Write a conclusion stating how increasing the temperature of the surrounding water affects the rate of cooling of the water in the test-tube.

Justify your answer by reference to the results in Table 1.1.

.....  
.....  
.....  
.....

[2]

- (e) Suggest **one** change to the experiment shown in Fig. 1.1 to ensure that the comparison of the effect of surrounding temperature on cooling is a fair test.

Explain why the change is an improvement.

change .....

.....

explanation .....

.....

[2]

- (f) The students use a measuring cylinder to measure 200 cm<sup>3</sup> of cold water.

Describe briefly how to read a measuring cylinder to obtain an accurate value for the volume of water. You may draw a diagram.

.....

.....

.....

..... [2]

[Total: 11]

- 2 A student is investigating the resistance of three wires **A**, **B** and **C**. He is using the circuit shown in Fig. 2.1.

The circuit is set up to test wire **A**. The length,  $l$  of each wire is measured and recorded.

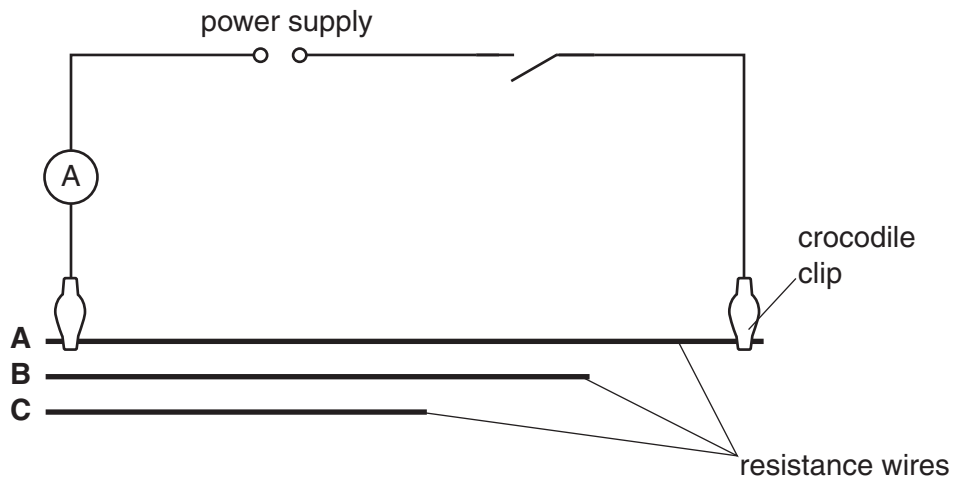

**Fig. 2.1**

- (a) On Fig. 2.1, draw a voltmeter connected so that it will measure the potential difference across wire **A**. [1]

- (b) In the first line of Table 2.1, record the potential difference  $V$  and current  $I$  for wire **A**, as shown in Figs. 2.2 and 2.3. [2]

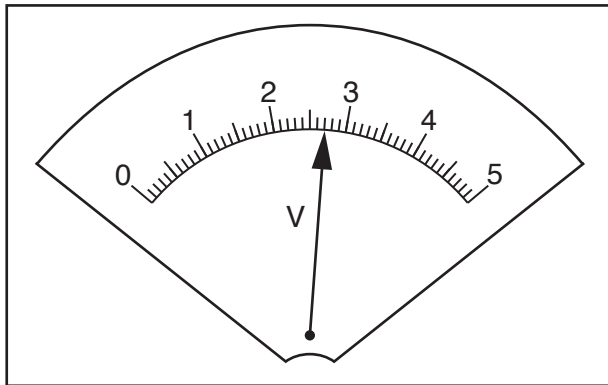

Fig. 2.2

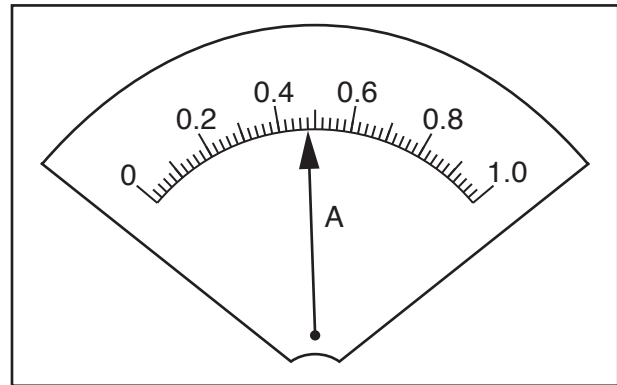

Fig. 2.3

Table 2.1

wire	$l/m$	$V/V$	$I/A$	$R/\Omega$
<b>A</b>	0.900			
<b>B</b>	0.500	2.4	0.75	
<b>C</b>	0.400	2.2	0.85	

- (c) The student connects the crocodile clips to wire **B** and then wire **C** in turn. His readings of potential difference and current are shown in Table 2.1.

Calculate, and record in Table 2.1, the resistance  $R$  of each wire.

Use the equation  $R = \frac{V}{I}$ .

[2]

- (d) (i) Calculate the resistance per unit length  $r$  of each wire using the equation  $r = \frac{R}{l}$ . Include the unit.

$r$  for wire **A** = .....

$r$  for wire **B** = .....

$r$  for wire **C** = .....

[2]

- (ii) Another student suggests that  $r$  should be the same for each wire.

State whether your results support this suggestion. Justify your statement with reference to your results.

statement .....

justification .....

.....

.....[2]

- (e) The student measures the length of each wire to be tested.

On Fig. 2.4, draw an arrow ( $\longleftrightarrow$ ) to indicate **precisely** between which two points he should measure  $l$ .

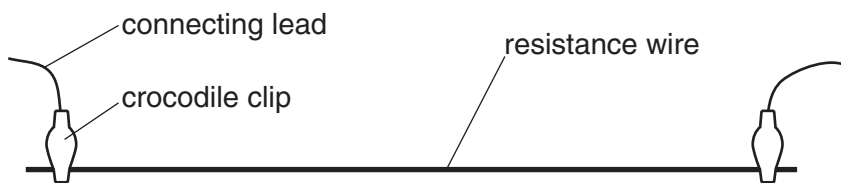

Fig. 2.4

[1]

- (f) One possible problem with this type of experiment is heating of the resistance wires.

Suggest a precaution that could be taken to reduce this.

.....

.....

.....[1]

[Total: 11]

[Turn over

- 3 Some students are investigating the magnification produced by a converging lens.

They are using the apparatus shown in Fig. 3.1.

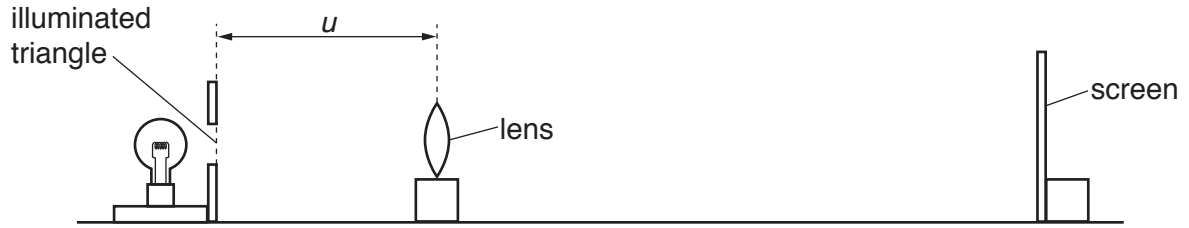

Fig. 3.1

- (a) A student sets the distance  $u$  between the illuminated triangle and the lens to 20.0 cm. She moves the screen until a sharp image of the triangle is seen on the screen.

The student measures the height of the illuminated triangle  $h_0$ .

$$h_0 = \dots\dots\dots 1.5 \text{ cm} \dots\dots\dots$$

Measure and record, in Table 3.1, the height of the image of the triangle  $h_1$  on the screen, as shown in Fig. 3.2. [1]

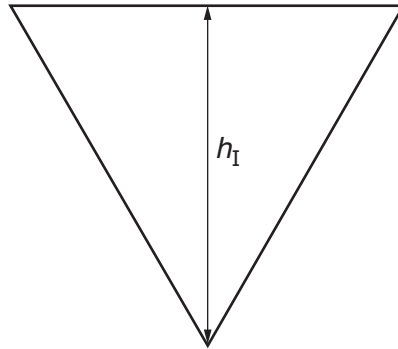

Fig. 3.2

Table 3.1

$u/\text{cm}$	$h_1/\text{cm}$	$M$
20.0		
25.0	2.25	
35.0	1.10	
45.0	0.75	
55.0	0.55	



- (b) The student measures the height  $h_I$  of the image for  $u$  values of 25.0 cm, 35.0 cm, 45.0 cm and 55.0 cm. Her results are shown in Table 3.1.

For each value of  $u$ , calculate and record in Table 3.1 a value for the magnification  $M$ .

Use the equation  $M = \frac{h_I}{h_O}$  and the value of  $h_O$  from (a). [1]

- (c) Plot a graph of  $M$  ( $y$ -axis) against  $u/\text{cm}$  ( $x$ -axis).

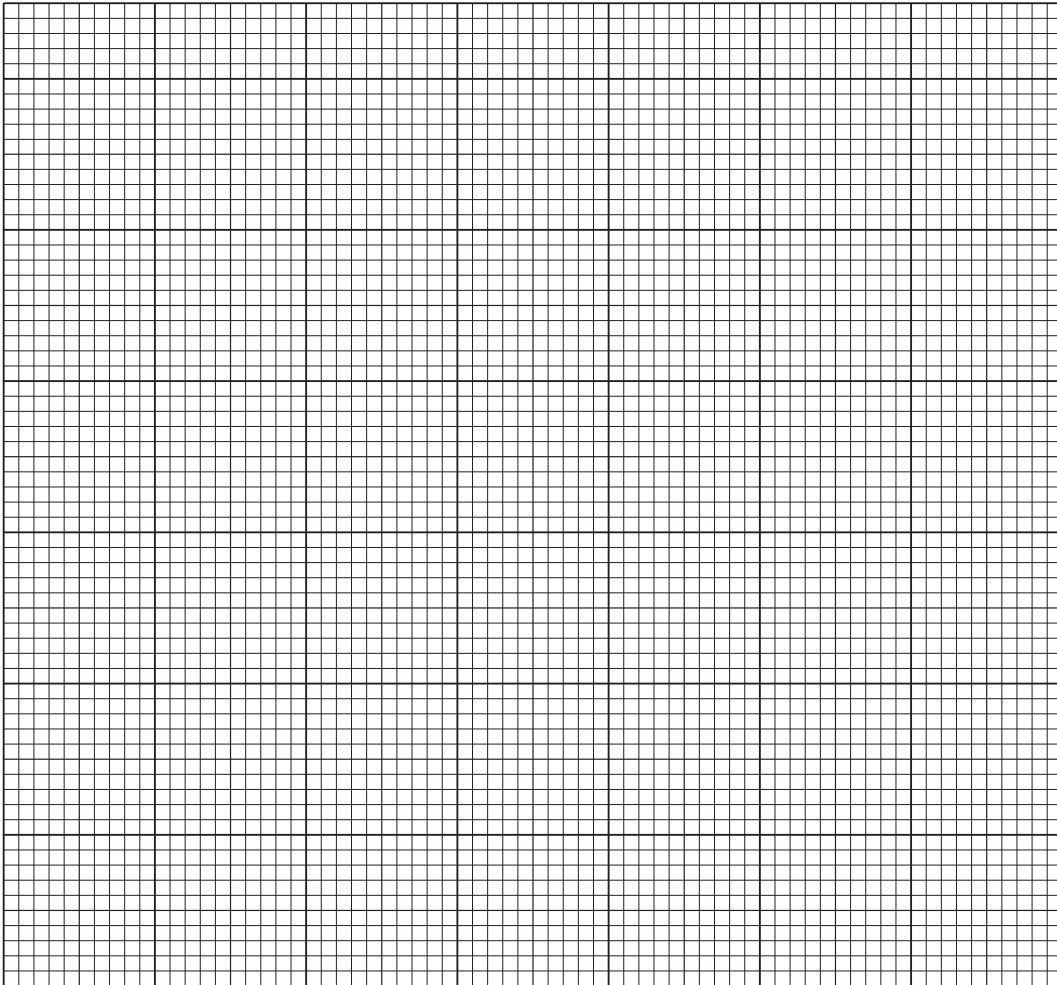

[4]

- (d) From your graph, determine the value of  $u$  when  $M = 1.0$ . Show clearly on your graph how you obtained the information.

$u = \dots\dots\dots$  [2]

- (e) Describe **one** difficulty that might be experienced when measuring the height of the image in this experiment. Suggest **one** improvement to the apparatus to overcome this.

difficulty .....

.....

improvement .....

.....

[2]

- (f) When setting up the apparatus, the student makes sure that the card with the illuminated triangle, the lens and the screen are all perpendicular to the bench.

Explain why this is an important precaution in this experiment.

.....

.....

.....[1]

[Total: 11]

- 4 A student is investigating how the material of a spring affects its behaviour when stretched.

The following apparatus is available to the student:

wires of different thickness, length and material  
a set of 10g masses and a set of 100g masses, both with hangers  
a wooden rod approximately 1 cm in diameter  
other standard laboratory equipment.

Plan an experiment which will enable you to test the extension of springs made from different types of wire.

In your plan, you should include:

- instructions for making a spring from the wire that is provided,
- what you will measure,
- instructions for carrying out the experiment,
- the variables you will keep the same to ensure the comparison is a fair test,
- any precaution which should be taken or difficulty which might occur,
- how you will present your results.

You may draw a diagram if it helps to explain your plan.

.....  
.....

