



Cambridge International Examinations
Cambridge International General Certificate of Secondary Education

CHEMISTRY

0620/13

Paper 1 Multiple Choice

May/June 2014

45 Minutes

Additional Materials: Multiple Choice Answer Sheet
 Soft clean eraser
 Soft pencil (type B or HB is recommended)

* 8 9 7 8 7 2 2 6 9 5 *

READ THESE INSTRUCTIONS FIRST

Write in soft pencil.
Do not use staples, paper clips, glue or correction fluid.
Write your name, Centre number and candidate number on the Answer Sheet in the spaces provided unless this has been done for you.
DO NOT WRITE IN ANY BARCODES.

There are **forty** questions on this paper. Answer **all** questions. For each question there are four possible answers **A, B, C** and **D**.
Choose the **one** you consider correct and record your choice in **soft pencil** on the separate Answer Sheet.

Read the instructions on the Answer Sheet very carefully.

Each correct answer will score one mark. A mark will not be deducted for a wrong answer.
Any rough working should be done in this booklet.
A copy of the Periodic Table is printed on page 16.
Electronic calculators may be used.

The syllabus is approved for use in England, Wales and Northern Ireland as a Cambridge International Level 1/Level 2 Certificate.

This document consists of **15** printed pages and **1** blank page.

- 1 The diagram shows the result of dropping a purple crystal into water.

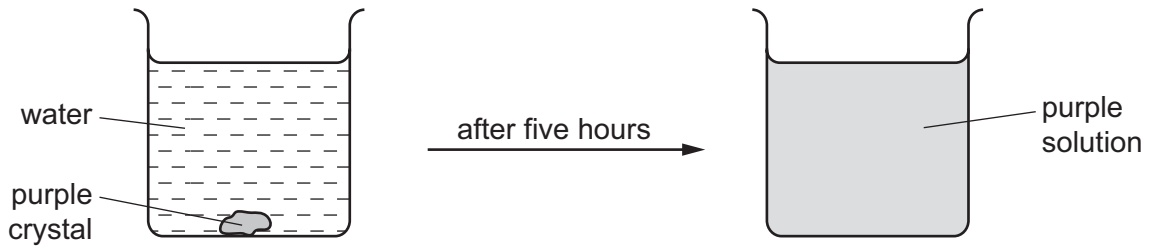

Which processes take place in this experiment?

	chemical reaction	diffusing	dissolving
A	✓	✓	✓
B	✓	x	✓
C	x	x	✓
D	x	✓	✓

- 2 Alcohol and water are completely miscible. This means when mixed together they form only one liquid layer.

Which method is used to separate alcohol from water?

- A** crystallisation
- B** filtration
- C** fractional distillation
- D** precipitation

3 The four pieces of apparatus shown below are used in chemical experiments.



burette

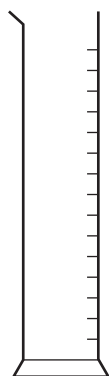

measuring
cylinder



pipette



thermometer

Which statement about the apparatus is correct?

- A The burette measures the volume of liquid added in a titration.
- B The measuring cylinder measures the mass of a substance used in an experiment.
- C The pipette measures the volume of gas given off in a reaction.
- D The thermometer measures the density of a solution.

4 The diagram shows the structure of an atom of element X.

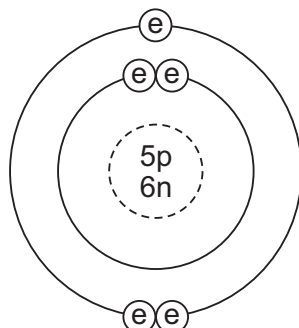

key

⊙ = electron

n = neutron

p = proton

⊙ = nucleus

What is X?

- A boron
- B carbon
- C sodium
- D sulfur

- 5 The 'lead' in a pencil is made of a mixture of graphite and clay.

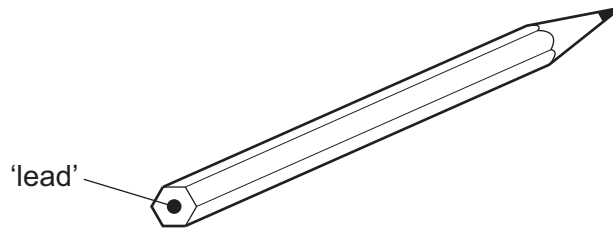

When the percentage of graphite is increased, the pencil slides across the paper more easily.

Which statement explains this observation?

- A** Graphite has a high melting point.
B Graphite is a form of carbon.
C Graphite is a lubricant.
D Graphite is a non-metal.
- 6 The diagrams show four particles.

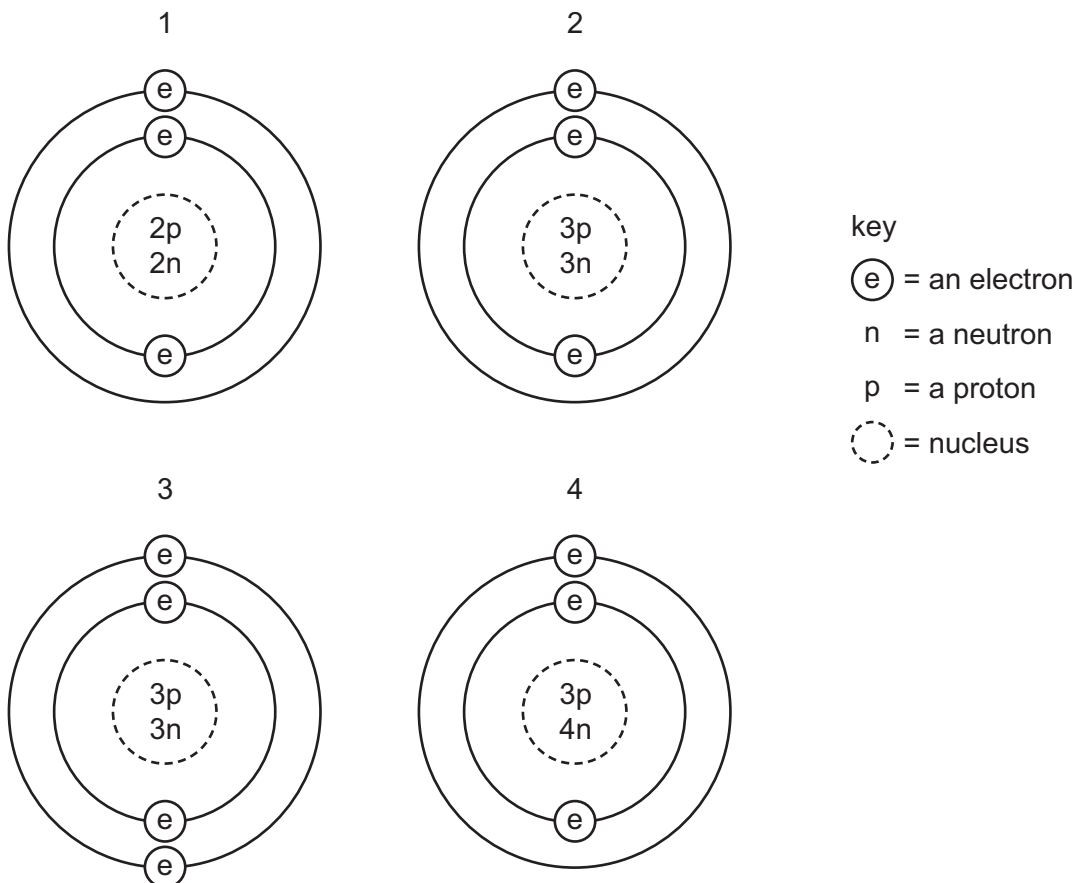

Which two diagrams show **atoms** that are isotopes of each other?

- A** 1 and 2 **B** 1 and 3 **C** 2 and 3 **D** 2 and 4

- 7 Solid F is an element.
Solid G is a compound.
Neither solid conducts electricity but G conducts electricity when dissolved in water.

These properties suggest that F is1..... and that G is2..... with3..... bonds.

Which words correctly complete gaps 1, 2 and 3?

	1	2	3
A	diamond	$AgCl$	covalent
B	diamond	$NaCl$	ionic
C	graphite	$AgCl$	ionic
D	graphite	$NaCl$	covalent

- 8 In athletics, banned drugs such as nandrolone have been taken illegally to improve performance. Nandrolone has the molecular formula $C_{18}H_{26}O_2$.

What is the relative molecular mass, M_r , of nandrolone?

(Relative atomic mass: H = 1; C = 12; O = 16)

- A** 46 **B** 150 **C** 274 **D** 306
- 9 A compound contains one atom of calcium, two atoms of hydrogen and two atoms of oxygen.
What is the correct chemical formula of the compound?
- A** CaO_2H_2 **B** $HOCaOH$ **C** H_2CaO_2 **D** $Ca(OH)_2$
- 10 Element X is in Group I of the Periodic Table. X reacts with element Y to form an ionic compound.

Which equation shows the process that takes place when X forms ions?

- A** $X + e^- \rightarrow X^+$
B $X - e^- \rightarrow X^-$
C $X + e^- \rightarrow X^-$
D $X - e^- \rightarrow X^+$

- 11 Which substance will **not** conduct electricity?

- A** aluminium
B copper
C plastic
D steel

12 Two chemical processes are described below.

- In the combustion of methane, energy is1..... .
- In the electrolysis of molten lead(II) bromide, energy is2..... .

Which words correctly complete gaps 1 and 2?

	1	2
A	given out	given out
B	given out	taken in
C	taken in	given out
D	taken in	taken in

13 Which equation shows an oxidation reaction?

- A** $C + O_2 \rightarrow CO_2$
- B** $CaCO_3 \rightarrow CaO + CO_2$
- C** $CaO + 2HCl \rightarrow CaCl_2 + H_2O$
- D** $N_2O_4 \rightarrow 2NO_2$

14 Some reactions are endothermic.

How does the temperature and energy change in an endothermic reaction?

	temperature change	energy change
A	decreases	energy taken in
B	decreases	energy given out
C	increases	energy taken in
D	increases	energy given out

15 Which products are formed at the anode and cathode when electricity is passed through molten lead(II) bromide?

	anode (+)	cathode (-)
A	bromide ions	lead ions
B	bromine molecules	lead atoms
C	lead atoms	bromine molecules
D	lead ions	bromide ions

- 16 An experiment is carried out to investigate the rate of reaction when calcium carbonate is reacted with hydrochloric acid.

The volume of carbon dioxide gas given off is measured at different intervals of time.

The diagram shows pieces of apparatus used to collect gases.

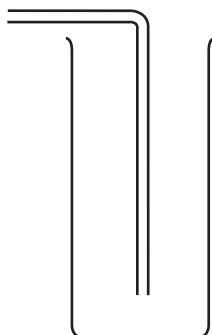

1
downward delivery



2
gas measuring
syringe

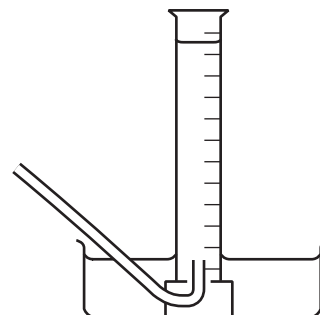

3
over water in
graduated tube

Which apparatus is suitable to collect and measure the volume of the carbon dioxide?

- A** 1, 2 and 3 **B** 2 and 3 only **C** 1 only **D** 3 only
- 17 In separate experiments, a catalyst is added to a reaction mixture and the temperature of the mixture is decreased.

What are the effects of these changes on the rate of the reaction?

	catalyst added	temperature decreased
A	faster	faster
B	faster	slower
C	slower	faster
D	slower	slower

- 18 Which statements about alkalis are correct?

- 1 When reacted with an acid, the pH of the alkali increases.
- 2 When tested with litmus, the litmus turns blue.
- 3 When warmed with an ammonium salt, ammonia gas is given off.

- A** 1, 2 and 3 **B** 1 and 2 only **C** 1 and 3 only **D** 2 and 3 only

19 Which acid reacts with ammonia to produce the salt ammonium sulfate?

- A hydrochloric
- B nitric
- C phosphoric
- D sulfuric

20 The equation shows a reaction that is reversed by changing the conditions.

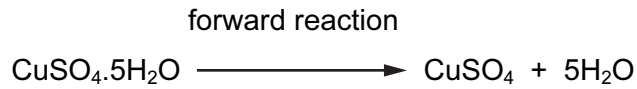

How can the forward reaction be reversed?

	by adding water	by heating
A	✓	✓
B	✓	x
C	x	✓
D	x	x

21 Only two elements are liquid at 20°C. One of these elements is shiny and conducts electricity.

This suggests that this element is a1..... and therefore its oxide is2..... .

Which words correctly complete gaps 1 and 2?

	1	2
A	metal	acidic
B	metal	basic
C	non-metal	acidic
D	non-metal	basic

- 26 In an experiment, three test-tubes labelled X, Y and Z were half-filled with dilute hydrochloric acid. A different metal was added to each test-tube. After a few minutes the following observations were made.

In tube X, bubbles slowly rose to the surface.

In tube Y, there was a rapid release of bubbles.

In tube Z, no bubbles were produced.

Which three metals match the observations?

	tube X	tube Y	tube Z
A	copper	zinc	iron
B	magnesium	iron	copper
C	zinc	magnesium	copper
D	zinc	magnesium	iron

- 27 The diagrams show two items that may be found in the home. Each item contains zinc.

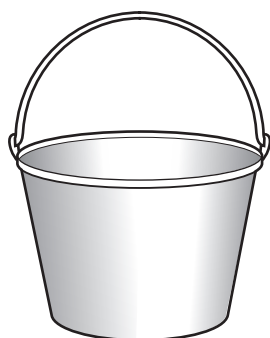

zinc plated bucket



brass door-knocker

In which is zinc used as an alloy?

	bucket	door-knocker
A	✓	✓
B	✓	x
C	x	✓
D	x	x

28 The diagram shows some uses of water in the home.

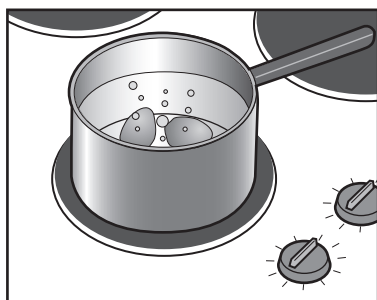

1

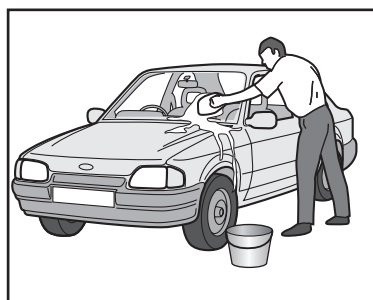

2



3

For which uses is it important for the water to have been treated?

- A** 1 only **B** 2 only **C** 3 only **D** 1, 2 and 3

29 The table shows properties of four metals.

Which metal is the most suitable for aircraft construction?

	density	strength	resistance to corrosion
A	high	high	low
B	high	low	low
C	low	high	high
D	low	low	high

30 The diagram shows a blast furnace.

In which part is iron ore changed to iron?

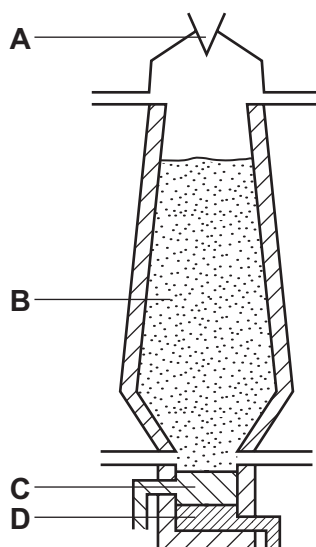

31 Acid rain is formed when sulfur dioxide and oxides of nitrogen dissolve in rain water.

Which problem is **not** caused by acid rain?

- A breathing difficulties
- B dying trees
- C erosion of statues
- D lowered pH of lakes

32 Which compound contains two of the three essential elements needed for a complete fertiliser?

- A ammonium chloride
- B ammonium nitrate
- C ammonium phosphate
- D ammonium sulfate

33 Four steel paper clips are treated as described before being placed in a beaker of water.

Which paper clip rusts most quickly?

- A coated with grease
- B dipped in paint and allowed to dry
- C electroplated with zinc
- D washed with soap and rinsed

34 When compound X is heated, it changes colour from green to black. Compound Y is formed and a gas is given off which turns limewater milky.

What are X and Y?

	X	Y
A	calcium carbonate	calcium oxide
B	copper carbonate	carbon
C	copper carbonate	copper oxide
D	copper sulfate	copper oxide

35 Which type of compound is shown?

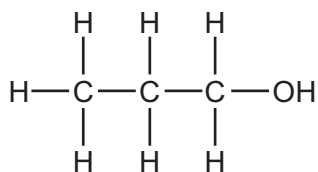

- A alcohol
- B alkane
- C alkene
- D carboxylic acid

36 The table shows the composition of four different types of petroleum (crude oil).

fraction	Arabian Heavy / %	Arabian Light / %	Iranian Heavy / %	North Sea / %
gasoline	18	21	21	23
kerosene	11.5	13	13	15
diesel oil	18	20	20	24
fuel oil	52.5	46	46	38

Which type of petroleum is best for the motor vehicle industry?

- A Arabian Heavy
- B Arabian Light
- C Iranian Heavy
- D North Sea

37 Which pollutant gas is produced by the decomposition of vegetation?

- A carbon monoxide
- B methane
- C nitrogen oxide
- D sulfur dioxide

38 X, Y and Z are three hydrocarbons.

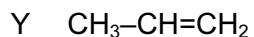
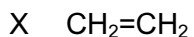

What do compounds X, Y and Z have in common?

- 1 They are all alkenes.
- 2 They are all part of the same homologous series.
- 3 They all have the same boiling point.

A 1, 2 and 3 **B** 1 and 2 only **C** 1 and 3 only **D** 2 and 3 only

39 Alkenes are manufactured by cracking hydrocarbons obtained from petroleum.

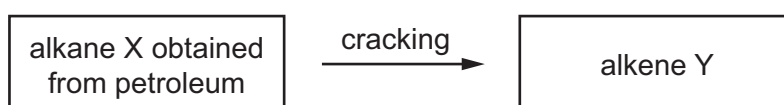

Which row describes the process of cracking?

	size of X molecules	size of Y molecules	catalyst required	temperature required
A	large	small	no	low
B	large	small	yes	high
C	small	large	no	low
D	small	large	yes	high

40 Which statements about ethanol are correct?

- 1 It can be made by fermentation.
- 2 It is an unsaturated compound.
- 3 It burns in air and can be used as a fuel.

A 1, 2 and 3 **B** 1 and 2 only **C** 1 and 3 only **D** 2 and 3 only

DATA SHEET

The Periodic Table of the Elements

Group																					
I	II											III	IV	V	VI	VII	0				
										1 H Hydrogen 1											4 He Helium 2
7 Li Lithium 3	9 Be Beryllium 4											11 B Boron 5	12 C Carbon 6	14 N Nitrogen 7	16 O Oxygen 8	19 F Fluorine 9	20 Ne Neon 10				
23 Na Sodium 11	24 Mg Magnesium 12											27 Al Aluminium 13	28 Si Silicon 14	31 P Phosphorus 15	32 S Sulfur 16	35.5 Cl Chlorine 17	40 Ar Argon 18				
39 K Potassium 19	40 Ca Calcium 20	45 Sc Scandium 21	48 Ti Titanium 22	51 V Vanadium 23	52 Cr Chromium 24	55 Mn Manganese 25	56 Fe Iron 26	59 Co Cobalt 27	59 Ni Nickel 28	64 Cu Copper 29	65 Zn Zinc 30	70 Ga Gallium 31	73 Ge Germanium 32	75 As Arsenic 33	79 Se Selenium 34	80 Br Bromine 35	84 Kr Krypton 36				
85 Rb Rubidium 37	88 Sr Strontium 38	89 Y Yttrium 39	91 Zr Zirconium 40	93 Nb Niobium 41	96 Mo Molybdenum 42	96 Tc Technetium 43	101 Ru Ruthenium 44	103 Rh Rhodium 45	106 Pd Palladium 46	108 Ag Silver 47	112 Cd Cadmium 48	115 In Indium 49	119 Sn Tin 50	122 Sb Antimony 51	128 Te Tellurium 52	127 I Iodine 53	131 Xe Xenon 54				
133 Cs Caesium 55	137 Ba Barium 56	139 La Lanthanum 57 *	178 Hf Hafnium 72	181 Ta Tantalum 73	184 W Tungsten 74	186 Re Rhenium 75	190 Os Osmium 76	192 Ir Iridium 77	195 Pt Platinum 78	197 Au Gold 79	201 Hg Mercury 80	204 Tl Thallium 81	207 Pb Lead 82	209 Bi Bismuth 83	209 Po Polonium 84	209 At Astatine 85	209 Rn Radon 86				
87 Fr Francium	226 Ra Radium	227 Ac Actinium 89 †																			

140 Ce Cerium 58	141 Pr Praseodymium 59	144 Nd Neodymium 60	147 Pm Promethium 61	150 Sm Samarium 62	152 Eu Europium 63	157 Gd Gadolinium 64	159 Tb Terbium 65	162 Dy Dysprosium 66	165 Ho Holmium 67	167 Er Erbium 68	169 Tm Thulium 69	173 Yb Ytterbium 70	175 Lu Lutetium 71
232 Th Thorium 90	238 Pa Protactinium 91	238 U Uranium 92	238 Np Neptunium 93	238 Pu Plutonium 94	238 Am Americium 95	238 Cm Curium 96	238 Bk Berkelium 97	238 Cf Californium 98	238 Es Einsteinium 99	238 Fm Fermium 100	238 Md Mendelevium 101	238 No Nobelium 102	238 Lr Lawrencium 103

*58-71 Lanthanoid series

†90-103 Actinoid series

Key

a
X
b

a = relative atomic mass
X = atomic symbol
b = proton (atomic) number

The volume of one mole of any gas is 24 dm³ at room temperature and pressure (r.t.p.).

Permission to reproduce items where third-party owned material protected by copyright is included has been sought and cleared where possible. Every reasonable effort has been made by the publisher (UCLES) to trace copyright holders, but if any items requiring clearance have unwittingly been included, the publisher will be pleased to make amends at the earliest possible opportunity.
 Cambridge International Examinations is part of the Cambridge Assessment Group. Cambridge Assessment is the brand name of University of Cambridge Local Examinations Syndicate (UCLES), which is itself a department of the University of Cambridge.