



UNIVERSITY OF CAMBRIDGE INTERNATIONAL EXAMINATIONS  
International General Certificate of Secondary Education

CANDIDATE  
NAME

CENTRE  
NUMBER

--	--	--	--	--

CANDIDATE  
NUMBER

--	--	--	--



**PHYSICS**

**0625/61**

Paper 6 Alternative to Practical

**May/June 2012**

**1 hour**

Candidates answer on the Question Paper.

No Additional Materials are required.

**READ THESE INSTRUCTIONS FIRST**

Write your Centre number, candidate number and name on all the work you hand in.

Write in dark blue or black pen.

You may use a pencil for any diagrams or graphs.

Do not use staples, paper clips, highlighters, glue or correction fluid.

**DO NOT WRITE IN ANY BARCODES.**

Answer **all** questions.

At the end of the examination, fasten all your work securely together.

The number of marks is given in brackets [ ] at the end of each question or part question.

For Examiner's Use	
1	
2	
3	
4	
5	
<b>Total</b>	

This document consists of **12** printed pages.



1 An IGCSE student is determining the mass of a metre rule using a balancing method.

For  
Examiner's  
Use

Fig. 1.1 shows the apparatus.

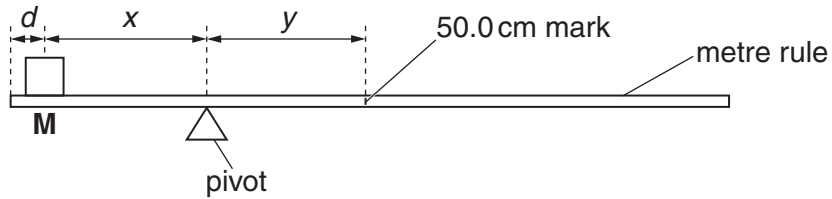

**Fig. 1.1**

Mass **M** is placed on the rule. The position of the pivot is adjusted until the rule balances.

(a) The student chooses a mass **M** which is similar to the mass of the metre rule. Suggest a suitable value for the mass.

suitable mass = ..... [1]

(b) The mass is cylindrical and has a diameter slightly larger than the width of the metre rule.

Describe briefly how you would place the mass so that its centre of mass is exactly over the 90.0 cm mark on the metre rule. You should draw a diagram and mark the position of the centre of mass on the cylinder.

.....  
 .....  
 ..... [2]

(c) From your experience of carrying out balancing experiments of this type, suggest one difficulty that you are likely to come across that could make the final result inaccurate.

.....  
 .....  
 ..... [1]

- (d) The student takes a reading of  $x$  and the corresponding reading of  $y$ . He then calculates the mass of the metre rule.

Suggest how you would improve the reliability of the value of the mass of the metre rule, using this method.

.....  
..... [1]

- (e) Another student carries out a similar experiment to determine the mass of a 50 cm metal strip. She calculates the mass and writes down “mass = 234.872 g”.

She checks the mass on an accurate balance. The value is 235 g. She thinks she must have made a mistake in her experiment.

Write a brief comment on the accuracy of her experimental result.

.....  
.....  
..... [1]

[Total: 6]

2 The IGCSE class is investigating the heating of a thermometer bulb.

The apparatus is shown in Figs. 2.1, 2.2 and 2.3.

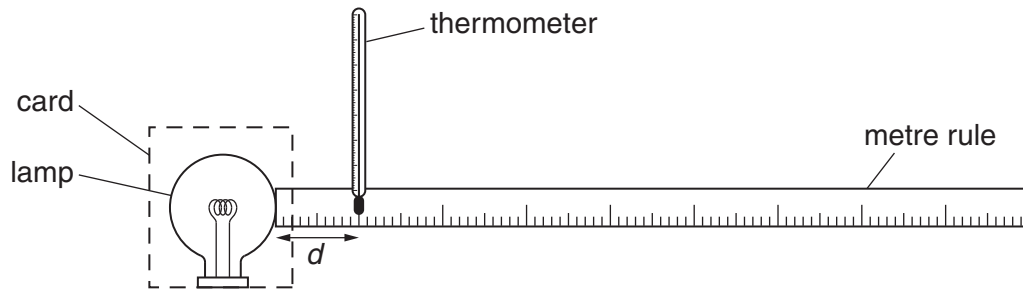

Fig. 2.1

(a) Record the value of room temperature  $\theta_R$  shown on the thermometer.

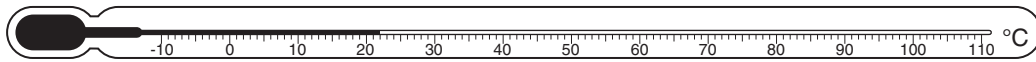

Fig. 2.2

$$\theta_R = \dots\dots\dots [1]$$

(b) A student switches on the lamp and places the thermometer so that its bulb is a horizontal distance  $d = 100$  mm from the surface of the lamp, as shown in Fig. 2.1. She records the distance  $d$  between the thermometer bulb and the surface of the lamp. She also records the temperature  $\theta$  shown on the thermometer. She repeats the procedure using values of  $d$  of 80 mm, 60 mm, 40 mm, 20 mm and 10 mm. The temperature readings are shown in Table 2.1.

- (i) Record the  $d$  values in the table.  
(ii) Complete the column headings in the table.

Table 2.1

$d/$	$\theta/$
	52
	56
	61
	67
	75
	86

[2]

- (c) The student moves the thermometer away from the lamp and waits for about a minute for the thermometer to cool. She places the thermometer so that its bulb is a vertical distance  $d_V = 100\text{ mm}$  from the top surface of the lamp, as shown in Fig. 2.3.

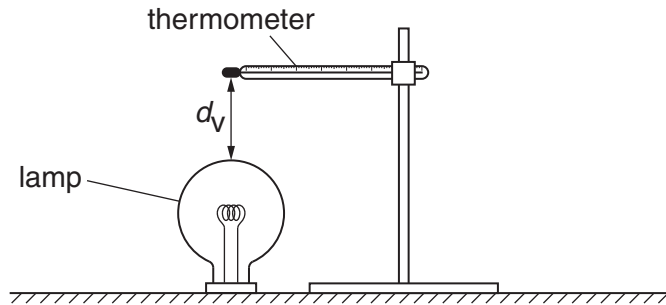

Fig. 2.3

She records the temperature  $\theta_V$  shown on the thermometer:  $\theta_V = 55^\circ\text{C}$ .

Calculate the difference between  $\theta_V$  and the thermometer reading  $\theta_H$  at a horizontal distance of 100 mm from the lamp. State whether  $\theta_V$  is higher, lower or the same as  $\theta_H$ .

temperature difference = .....

$\theta_V$  is ..... [1]

- (d) A student suggests that  $\theta_V$  will be higher than the thermometer reading  $\theta_H$  because thermal energy will travel by infra-red radiation and convection to the thermometer bulb above the lamp but by infra-red radiation only when the bulb is to one side of the lamp.

If the experiment were to be repeated in order to investigate this suggestion it would be important to control the conditions. Suggest two such conditions, relevant to this investigation, that should be controlled.

1. ....

2. ....

[2]

- (e) Briefly describe a precaution that you would take in this experiment in order to obtain a reliable result.

.....

.....

..... [1]

[Total: 7]

- 3 The IGCSE class is determining the resistance of a fixed resistor in a circuit.

The circuit is shown in Fig. 3.1.

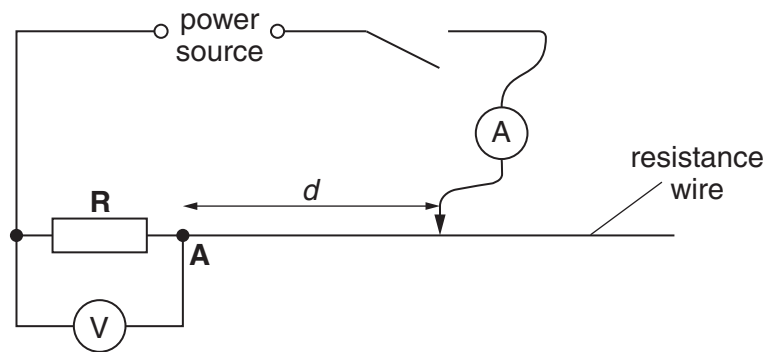

**Fig. 3.1**

- (a) A student places the sliding contact on the resistance wire at a distance  $d = 10.0$  cm from point **A**. He measures the current  $I$  in the circuit and the p.d.  $V$  across the resistor **R**. He repeats the procedure using  $d$  values of 30.0 cm, 50.0 cm, 70.0 cm and 90.0 cm.

The readings are shown in Table 3.1.

**Table 3.1**

	$V/V$	$I/A$
10.0	1.7	1.13
30.0	1.3	0.87
50.0	1.0	0.67
70.0	0.8	0.53
90.0	0.7	0.47

- (i) Complete the column headings in the table.

- (ii) Plot a graph of  $V/V$  ( $y$ -axis) against  $I/A$  ( $x$ -axis). You do not need to include the origin  $(0, 0)$  on your graph.

For  
Examiner's  
Use

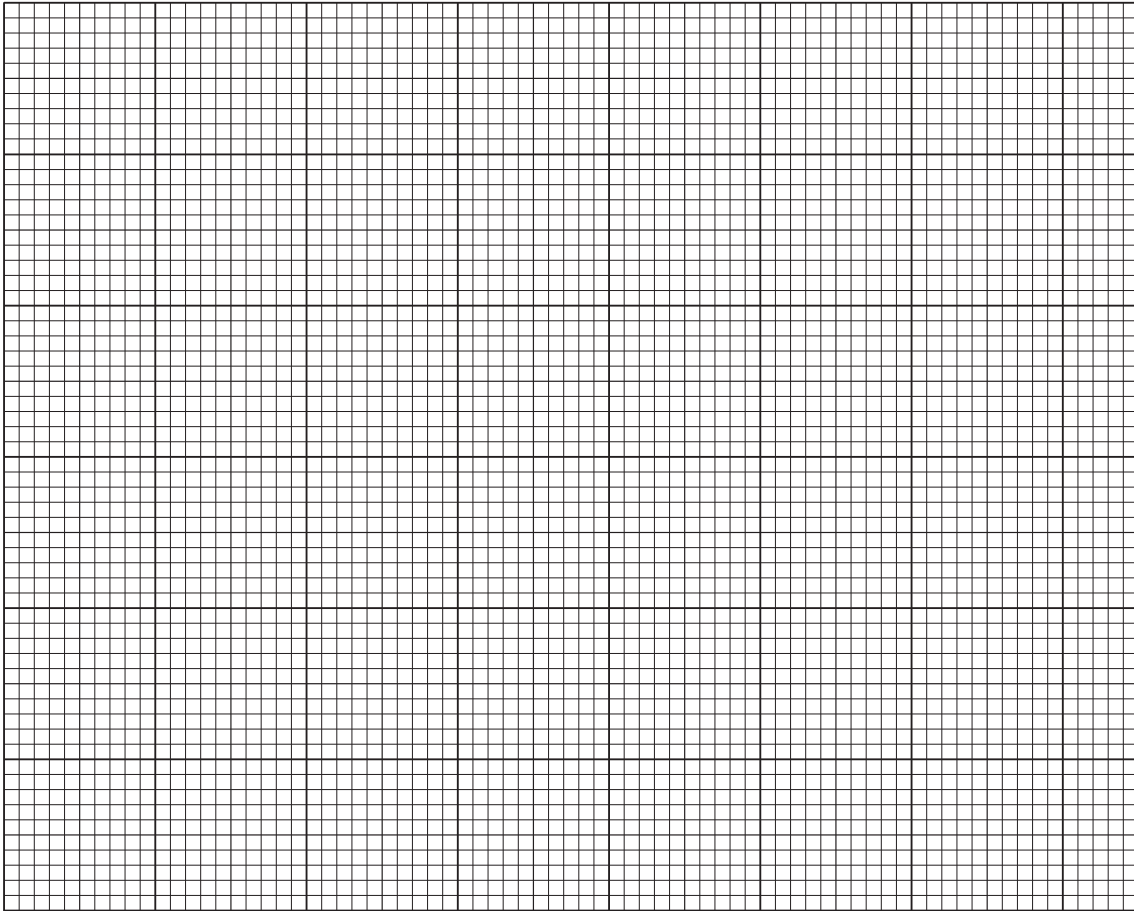

[5]

- (iii) Determine the gradient  $G$  of the graph. Show clearly on the graph how you obtained the necessary information.

$$G = \dots\dots\dots [3]$$

- (b) The gradient  $G$  of the graph is numerically equal to the resistance  $R$  of the resistor  $R$ .

Write a value for the resistance  $R$  to a suitable number of significant figures for this experiment.

$$R = \dots\dots\dots [2]$$

[Total: 10]

- 4 The IGCSE class is determining the focal length of a lens.

The apparatus is shown in Fig. 4.1.

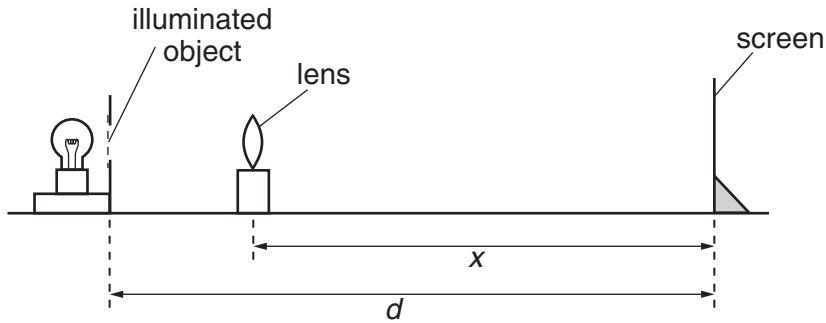

Fig. 4.1

- (a) A student places the lens between the object and the screen and close to the object. She moves the lens towards the screen until a clearly focused, **enlarged** image is formed on the screen.

- (i) On Fig. 4.1, measure and record the distance  $d$  between the object and the screen.

$d =$  .....

- (ii) On Fig. 4.1, measure and record the distance  $x$  between the centre of the lens and the screen.

$x =$  .....

[2]

- (iii) Fig. 4.1 is drawn one tenth actual size.

1. Calculate the actual distance  $D$  between the object and the screen.

$D =$  .....

2. Calculate the actual distance  $X$  between the centre of the lens and the screen.

$X =$  .....

[1]

- (b) Without moving the illuminated object or the screen, the student moves the lens towards the screen until a clearly focused, **diminished** image is formed on the screen. She measures the distance  $Y$  between the centre of the lens and the screen:  $Y = 19.0$  cm.

Calculate the focal length  $f$  of the lens using the equation  $f = \frac{XY}{D}$ .

$f =$  ..... [2]



- (c) The student turns the lens through an angle of  $180^\circ$  and repeats the procedure obtaining a value for the focal length  $f = 14.7$  cm.

Theory suggests that the two values of the focal length  $f$  should be the same. State whether the results support this theory and justify your answer by reference to the results.

statement .....

justification .....

.....

[2]

- (d) Briefly describe a precaution that you would take in this experiment in order to obtain a reliable result.

.....

.....

..... [1]

[Total: 8]

- 5 The IGCSE class is determining the internal volume of a test-tube using two displacement methods.

For  
Examiner's  
Use

The apparatus used is shown in Figs. 5.1, 5.2 and 5.3.

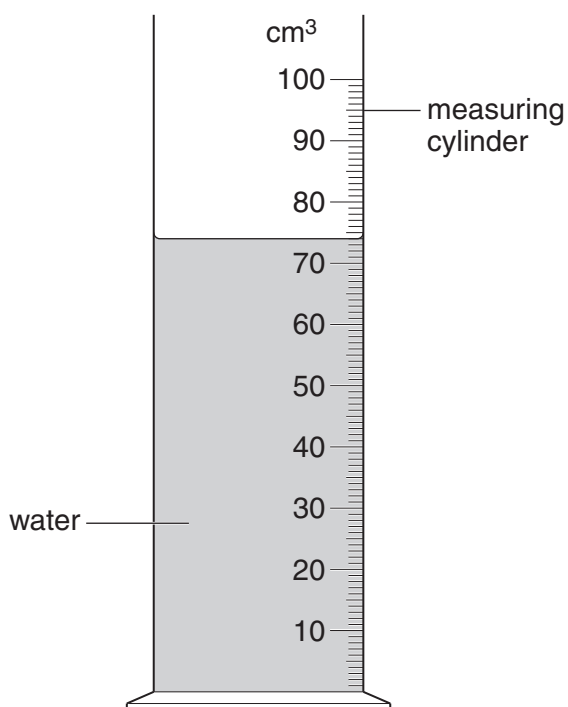

Fig. 5.1

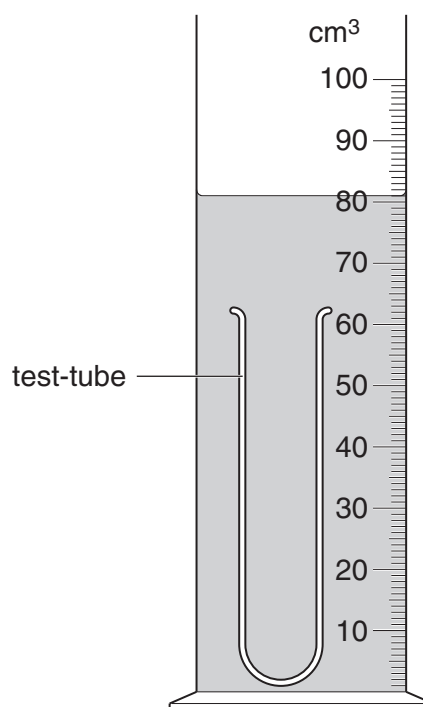

Fig. 5.2

- (a) (i) Fig. 5.1 shows water in a measuring cylinder. Record the volume  $V_1$  of the water.

$$V_1 = \dots\dots\dots [1]$$

- (ii) On Fig. 5.1, show clearly the line of sight that you would use to obtain an accurate volume reading. [2]

- (b) (i) A student lowers a test-tube, closed end first, into the water in the measuring cylinder and pushes the tube down until it is filled with water. From Fig. 5.2, record the new water level  $V_2$ .

$$V_2 = \dots\dots\dots$$

- (ii) Calculate the volume  $V_G$  of the glass of the test-tube using the equation  $V_G = (V_2 - V_1)$ .

$$V_G = \dots\dots\dots [2]$$

- (c) The student removes the test-tube from the measuring cylinder and empties the water back into the measuring cylinder. He then puts the test-tube, open end first, into the water in the measuring cylinder and carefully pushes it down with his finger until it is covered with water as shown in Fig. 5.3.

For  
Examiner's  
Use

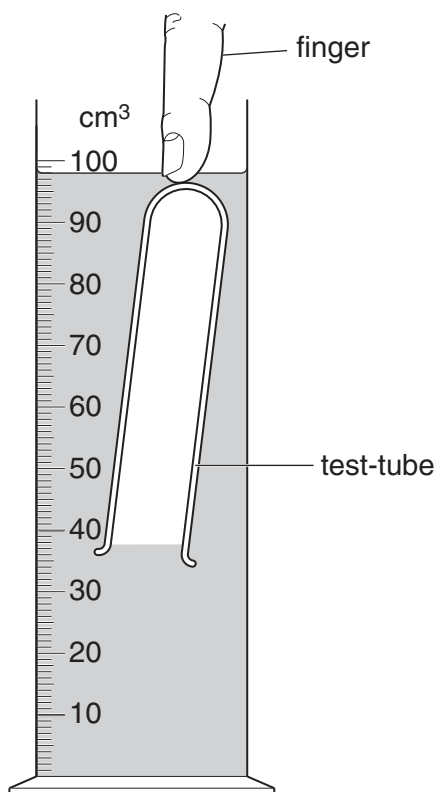

**Fig. 5.3**

- (i) Record the new water level  $V_3$ .

$$V_3 = \dots\dots\dots$$

- (ii) Calculate the increase in water level ( $V_3 - V_1$ ).

$$(V_3 - V_1) = \dots\dots\dots$$

- (iii) Calculate the volume  $V_A$  of air in the test-tube using the equation  $V_A = (V_3 - V_1) - V_G$ .

$$V_A = \dots\dots\dots [1]$$

- (d) The student removes the test-tube from the measuring cylinder and fills the test-tube with water from a beaker. He pours the water from the test-tube into an empty measuring cylinder and records the volume  $V_W$  of water:

$$V_W = \dots 18\text{cm}^3 \dots$$

The student has attempted to determine the internal volume of the test-tube by two methods. His two values for the internal volume are  $V_A$  and  $V_W$ .

Assuming that the experiments have been carried out correctly and carefully and that the measuring cylinder scale is accurate, suggest two reasons why the value  $V_A$  may be inaccurate and two reasons why the value  $V_W$  may be inaccurate.

$V_A$ :

reason 1 .....

.....

reason 2 .....

.....

$V_W$ :

reason 1 .....

.....

reason 2 .....

.....

[3]

[Total: 9]