



UNIVERSITY OF CAMBRIDGE INTERNATIONAL EXAMINATIONS
International General Certificate of Secondary Education

CANDIDATE
NAME

CENTRE
NUMBER

--	--	--	--	--

CANDIDATE
NUMBER

--	--	--	--



GEOGRAPHY

Paper 2

0460/02

May/June 2008

1 hour 30 minutes

Candidates answer on the Question Paper.

Additional Materials: Ruler
 Protractor
 Plain paper

1:25 000 Survey Map Extract is enclosed with this question paper.

READ THESE INSTRUCTIONS FIRST

Write your Centre number, candidate number and name on all the work you hand in.
Write in dark blue or black pen.
You may use a soft pencil for any diagrams, graphs or rough working.
Do not use staples, paper clips, highlighters, glue or correction fluid.
DO NOT WRITE ON ANY BARCODES.

Answer **all** questions.
The Insert contains Photograph A for Question 3.
Sketch maps and diagrams should be drawn whenever they serve to illustrate an answer.

The Survey Map Extract and the Insert are **not** required by the Examiner.

At the end of the examination, fasten all your work securely together.
The number of marks is given in brackets [] at the end of each question or part question.

For Examiner's Use	
Q1	
Q2	
Q3	
Q4	
Q5	
Q6	
Total	

This document consists of **15** printed pages, **1** blank page and **1** Insert.



1 The map extract shows part of the island of Mauritius. The scale is 1:25 000.

(a) Fig. 1 shows the positions of some features in the north east of the map extract.

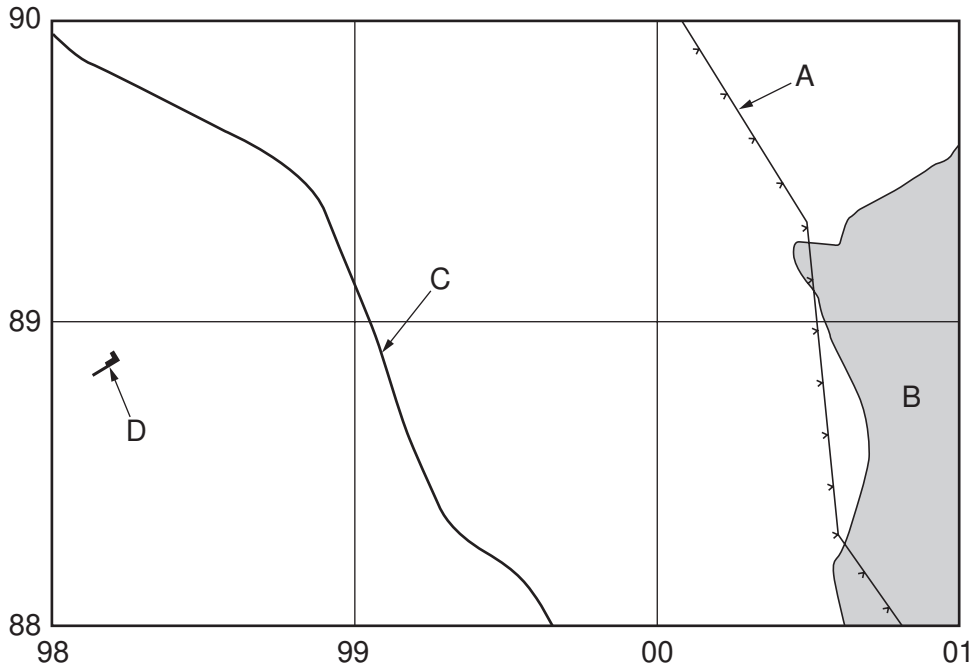

Fig. 1

Study the map and Fig. 1 and name the following features:

(i) feature A;

..... [1]

(ii) the plantation crop at B;

..... [1]

(iii) the class of road at C;

..... [1]

(iv) the named or public building at D.

..... [1]

(b) Describe the overall street pattern in the built-up areas of the map.

.....
..... [1]

(c) Look at the B4 St Paul Road from the junction with the B3 at Vacoas (954884) to the junction with the A10 at St Paul (981898).

(i) Measure the distance along the road. Give your answer in metres.

..... metres

(ii) Measure the bearing, from grid north, of the road from Vacoas to St Paul.

..... degrees

[2]

(d) State the six figure grid reference of the roundabout (circle) at the junction of the B5 and A10 roads at Curepipe.

.....

[1]

- (e) Fig. 2 shows two settlement areas shown on the map. These are grid square 9787 at Floreal and grid square 9986 at Curepipe.

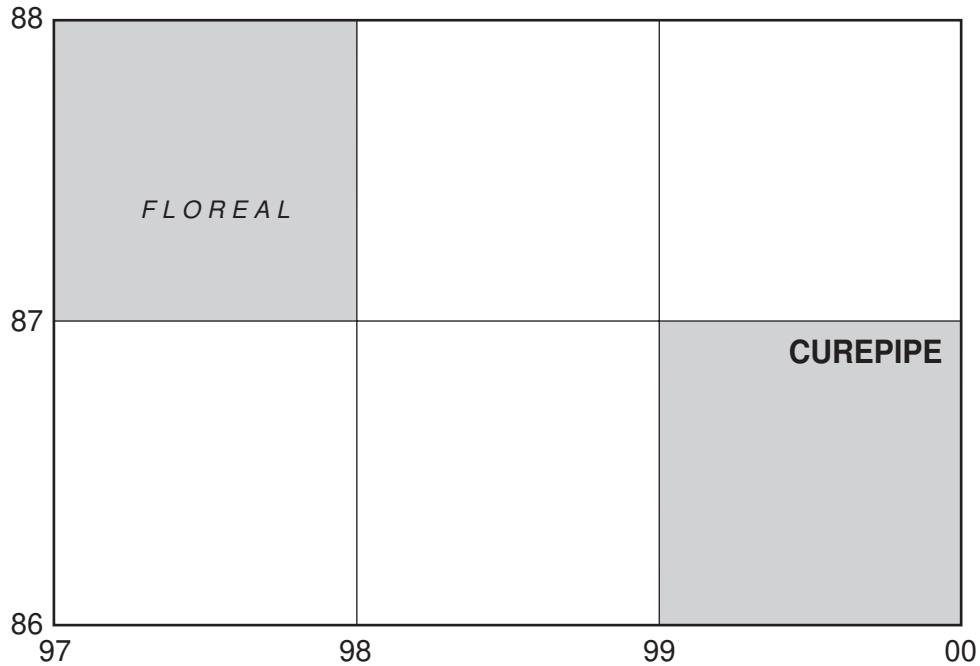

Fig. 2

Table 1 compares the features of the two grid squares. Complete the table by putting ticks in the correct **six** boxes. Use only **one** tick for each row.

	Floreal (9787)	Curepipe (9986)	Neither of these areas
Example: CBD	–	✓	–
River			
Motorway			
Low building density			
High order services			
Flat land			
Land sloping down to the north west			

Table 1

[6]

2 Study Fig. 4, which shows the ideal growth conditions for coral.

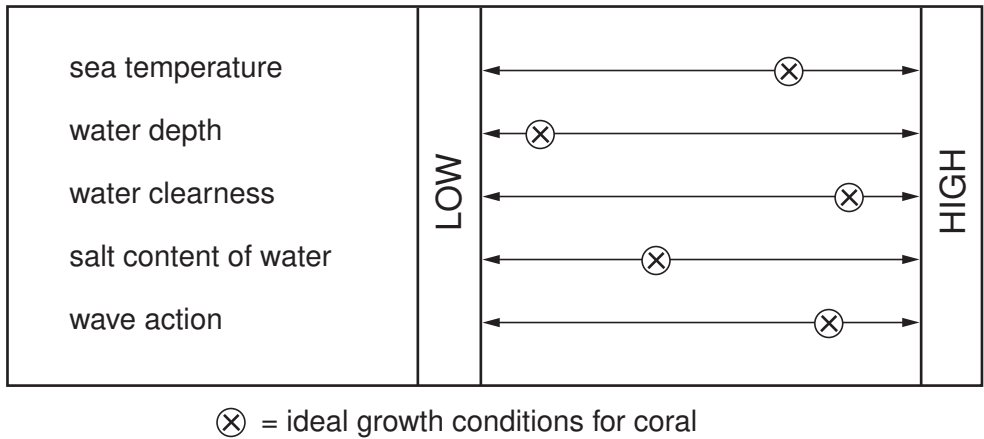

Fig. 4

(a) Fig. 5 shows the distribution of coral reefs in the world.

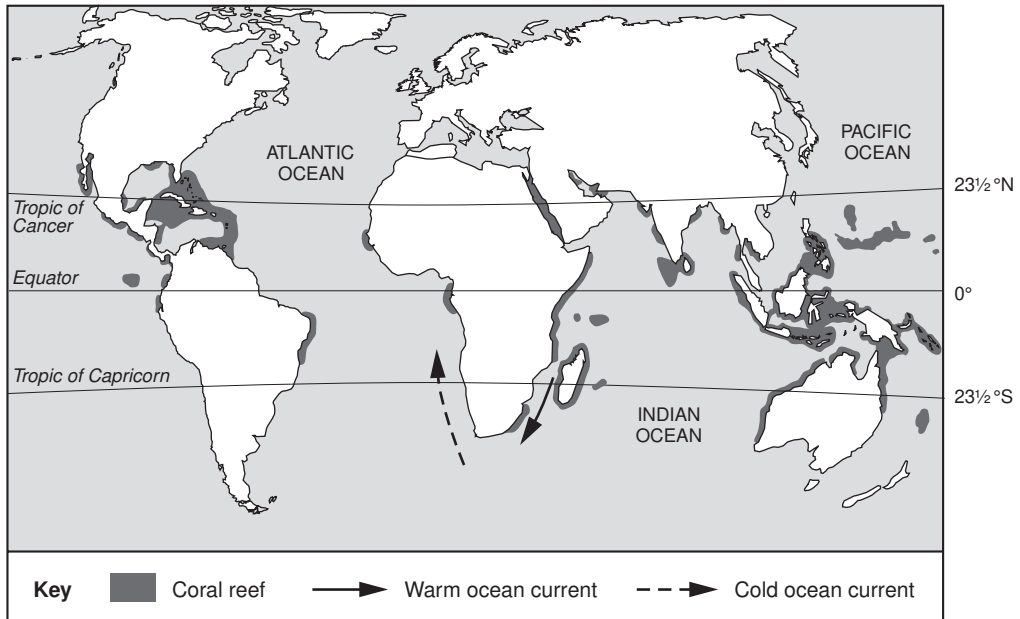

Fig. 5

(i) Between which lines of latitude is coral found?

..... [1]

(ii) Using Fig. 4, suggest **one** reason for this.

.....
 [1]

(iii) Suggest why there is coral on the east coast of southern Africa but not on the west coast.

.....

.....

.....

..... [2]

(b) Fig. 6 shows a map of an island and a coral reef.

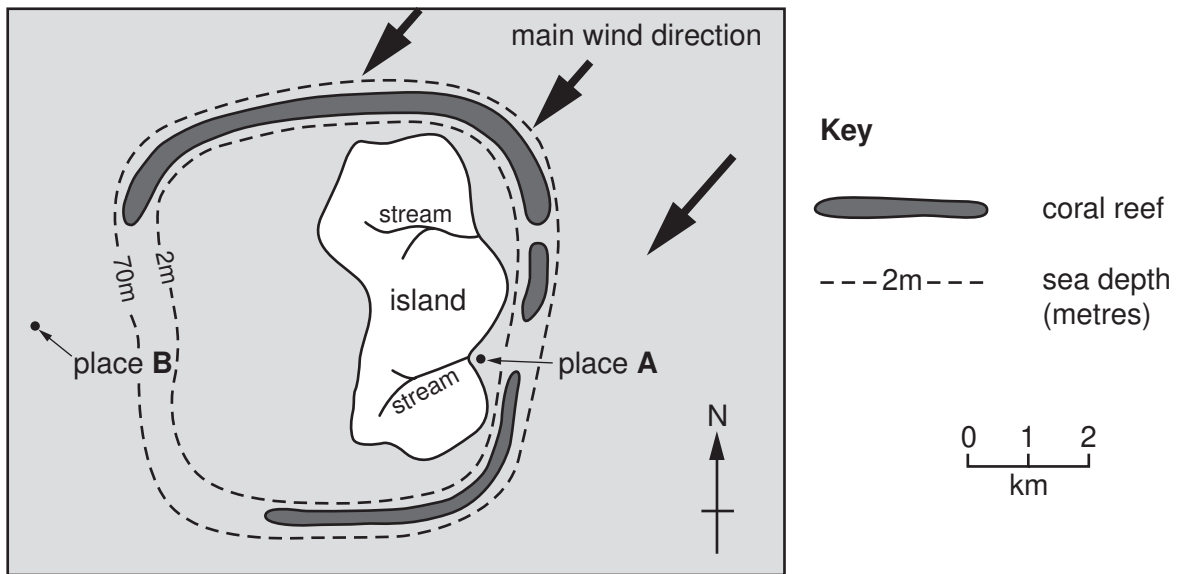

Fig. 6

Environmental conditions do not allow coral to grow at places **A** and **B** on the map. Using Fig. 4, for each place, suggest reasons why this is so.

Place **A**

.....

.....

.....

Place **B**

.....

.....

..... [4]

[Total: 8 marks]

- 3 Study Photograph A (Insert), which shows an area in southern Europe. Describe the **relief**, **settlement** and **agriculture** of the area shown in the photograph.

Relief

.....

.....

.....

.....

.....

.....

.....

.....

.....

.....

Settlement

.....

.....

.....

.....

.....

.....

.....

.....

.....

.....

- 4 Study Fig. 7, which gives information about high technology industries, and Fig. 8, which shows the location of Silicon Valley, an important centre for high technology industries in the USA.

High technology industries

These industries involve making and using silicon chips, computers, semi-conductor devices and computer-controlled machinery. The location of these industries does not depend on the factors which affect the location of many other more traditional manufacturing industries. Important factors include:

- a highly educated, specialised workforce
- proximity to research facilities
- nearness to other high-tech industries so that ideas, staff and equipment can be shared
- nearness to large urban markets is useful but high-value, low-bulk goods can bear the cost of transport, often to overseas markets
- a pleasant environment for the workforce to live in

Fig. 7

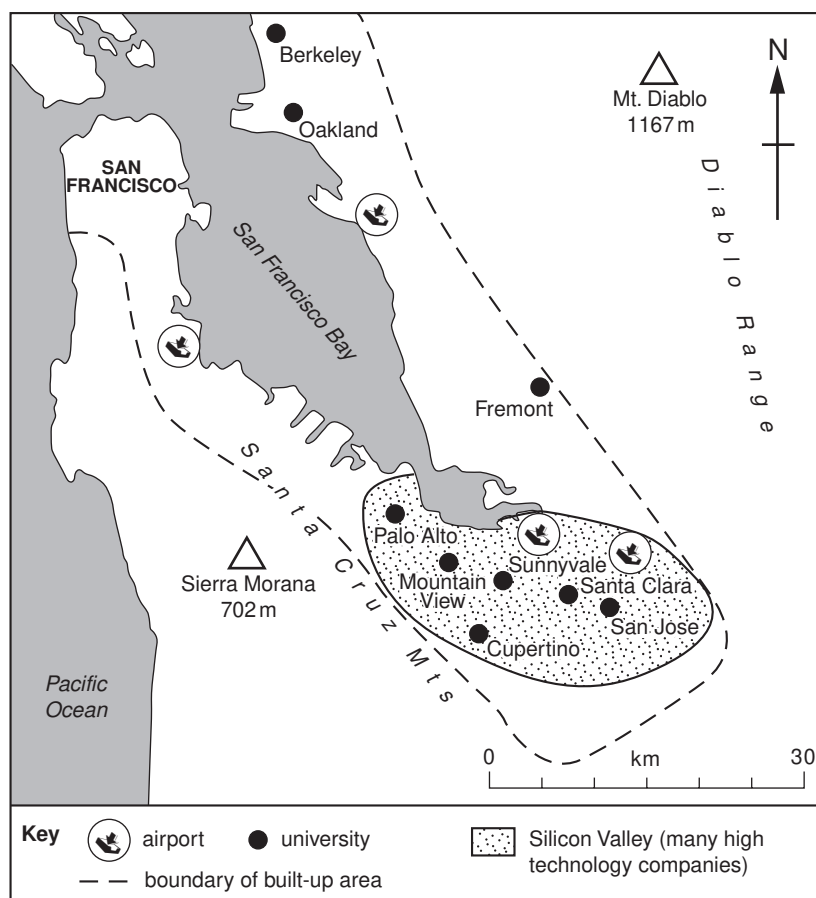

Fig. 8

5 Table 2 shows weather information for Pretoria, South Africa, for five days in 2006.

date	maximum temperature (°C)	minimum temperature (°C)	pressure (mb)	relative humidity (%)
July 29	22	2	1025	26
July 30	22	2	1023	22
July 31	20	7	1019	
Aug 1	22	1	1015	31
Aug 2	18	2	1020	29

Table 2

(a) Fig. 9 shows the temperatures for the five days.

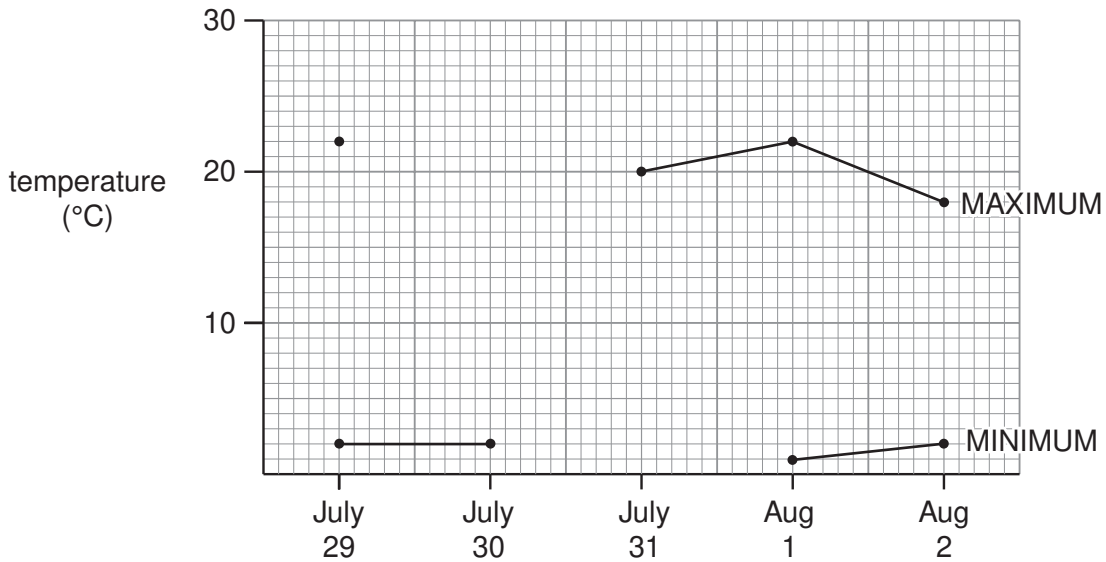

Fig. 9

(i) Use the information in Table 2 to complete Fig. 9. [2]

(ii) Which date has the greatest range of temperature?
..... [1]

(iii) The units of pressure are abbreviated as mb. What does mb stand for?
..... [1]

- (b) The relative humidity for July 31 has been omitted from Table 2. This can be calculated from the readings of the wet and dry bulb thermometers (hygrometer), shown in Fig. 10, and the conversion table, shown in Table 3.

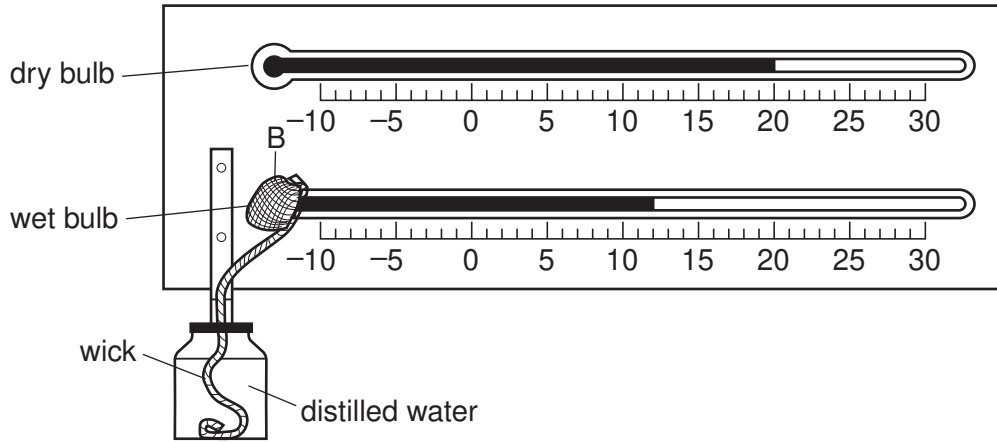

Fig. 10

dry bulb reading (°C)	wet bulb depression (°C)								
	1	2	3	4	5	6	7	8	9
	%	%	%	%	%	%	%	%	%
24	92	84	77	69	62	56	49	43	37
22	92	83	76	48	61	54	47	40	34
20	91	83	74	66	59	51	44	37	30
18	91	82	73	65	56	49	41	34	27

Table 3

- (i) State the readings of the wet and dry bulb thermometers in Fig. 10.

Wet bulb

Dry bulb

[1]

- (ii) Calculate the depression of the wet bulb.

..... [1]

- (iii) Using your answers to (b)(i) and (ii) and Table 3, state the relative humidity for July 31.

..... [2]

[Total: 8 marks]

6 Four types of graph used in geography are:

- a triangular graph
- a bar graph
- a scatter graph
- a line graph

For each of the following four examples, (a) – (d), choose the most appropriate type of graph from the list above. Name the type of graph and draw a **labelled** sketch of it.

You may use each type of graph **once** only.

(a) A graph to show rainfall totals for months of the year.

Name of type of graph

Labelled sketch

[2]

(b) A graph to show change in the birth rate over a number of years.

Name of type of graph

Labelled sketch

[2]

- (c) A graph to show the relationship between birth rates and death rates in a group of countries.

Name of type of graph

Labelled sketch

[2]

- (d) A graph to show the percentages of primary, secondary and tertiary employment in a group of countries.

Name of type of graph

Labelled sketch

[2]

[Total: 8 marks]

BLANK PAGE

Copyright Acknowledgements:

Question 3 Photograph A D. Kelly © UCLES.
Question 4 Fig. 8 © Brian Price, Paul Guinness; *North America: An Advanced Geography*; Hodder Arnold H&S; 1997.
Map Reproduced by permission of Ordnance Survey on behalf of HMSO © Crown copyright (2007). All rights reserved. Ordnance Survey Licence number 100046560.

Permission to reproduce items where third-party owned material protected by copyright is included has been sought and cleared where possible. Every reasonable effort has been made by the publisher (UCLES) to trace copyright holders, but if any items requiring clearance have unwittingly been included, the publisher will be pleased to make amends at the earliest possible opportunity.

University of Cambridge International Examinations is part of the Cambridge Assessment Group. Cambridge Assessment is the brand name of University of Cambridge Local Examinations Syndicate (UCLES), which is itself a department of the University of Cambridge.