

CAMBRIDGE INTERNATIONAL EXAMINATIONS  
General Certificate of Education  
Advanced Level

**PHYSICS**

**9702/05**

Paper 5 Practical Test

May/June 2003

CONFIDENTIAL INSTRUCTIONS

**1 hour 30 minutes**

**Great care should be taken that any confidential information given does not reach the candidates either directly or indirectly.**

This document consists of **8** printed pages.



## Instructions for preparing apparatus

These instructions detail the apparatus required for the experiment in this paper. A summary of the question that will be presented to the candidates is included, to allow the Physics teacher to test the apparatus appropriately. No access is permitted to the Question Paper in advance of the examination session.

## Number of sets of apparatus

In addition to a few spare sets, there should ideally be one set of apparatus per candidate.

If this is not possible, then the minimum number of sets of apparatus to be provided should be sufficient for half the candidates to carry out the experiment simultaneously, plus a few spare sets. With this number of sets available, a staggered start to the examination will be required, which may be organised as shown in the diagram below.

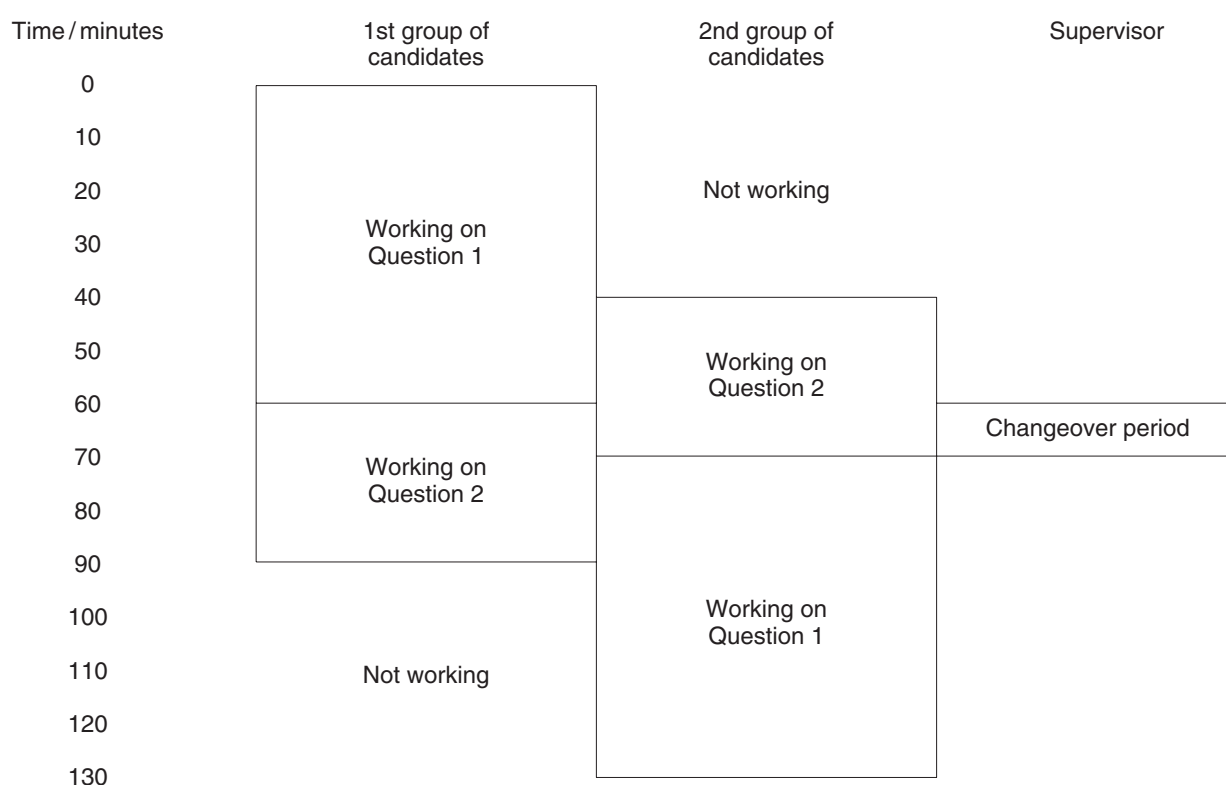

## Instructions for the Practical Physics Supervisor

Candidates should be informed that, if they find themselves in real difficulty, they may ask the Supervisor for practical assistance but that the extent of this assistance will be reported to the Examiner, who may make a deduction of marks.

The Supervisor should complete the report form on pages 7 and 8 and enclose it in the envelope containing the answers of the candidates. A note of any help given to, or any particular difficulties experienced by, a candidate should also be enclosed, especially if the Examiner would be unable to discover these from the written answers.

It is assumed that candidates will provide themselves with such standard items as a 30 cm rule, a pair of compasses, a 0° to 180° protractor, a set square and a calculator.

Squared paper should be available.

Whenever a stopwatch or stopclock is specified, candidates should be advised, in advance, that they may, if they wish, use quartz wristwatches with stopwatch facilities.

**Question 1**

Candidates will be required to investigate the relation between the angle turned by a suspended magnadur magnet and the current in a straight wire located near to the magnet.

**Apparatus requirements (per set of apparatus unless otherwise specified)**

Half-metre wood or plastic rule

55 cm length of 20 swg (0.9 mm diameter) bare copper wire. The wire should be attached to the narrow edge of the rule using tape so that a short length of wire protrudes at each end, as shown in Fig. 1.1.

**Fig. 1.1**

360° protractor. The protractor should be attached to the top of the rule using sellotape. The 0° to 180° line should lie along the copper wire as shown in Fig. 1.2.

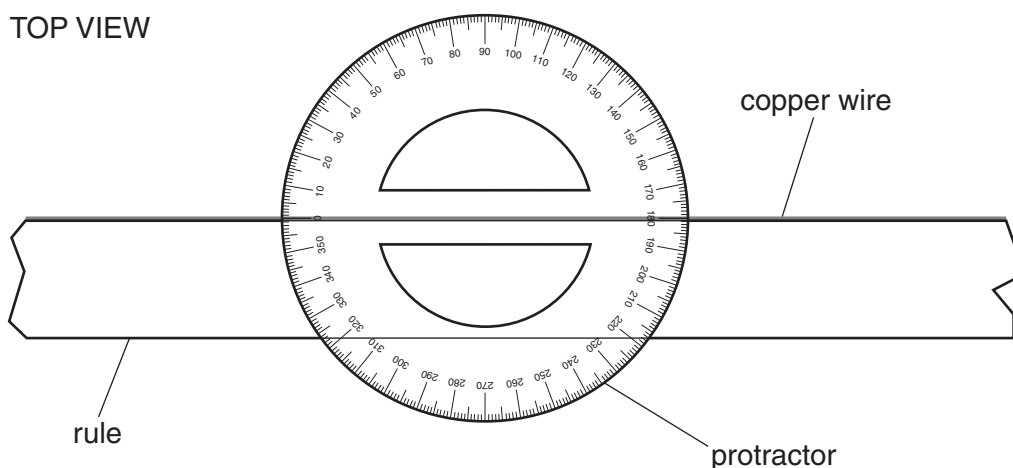
**Fig. 1.2**

2 crocodile clips (to be used to attach connecting leads to the copper wire)

Sheet of white paper (to be placed below the protractor to aid the reading of the scale)

Stand, boss and clamp

Ceramic magnadur magnet (e.g. Philip Harris A47156) with poles on the faces

Pointer. A thin wooden rod has been found to be suitable. The length of the pointer should be slightly greater than the diameter of the protractor. The pointer should be attached to a narrow length of card of length about 7 cm (see note 2). The other end of the card should be attached to the magnet, as shown in Fig. 1.3.

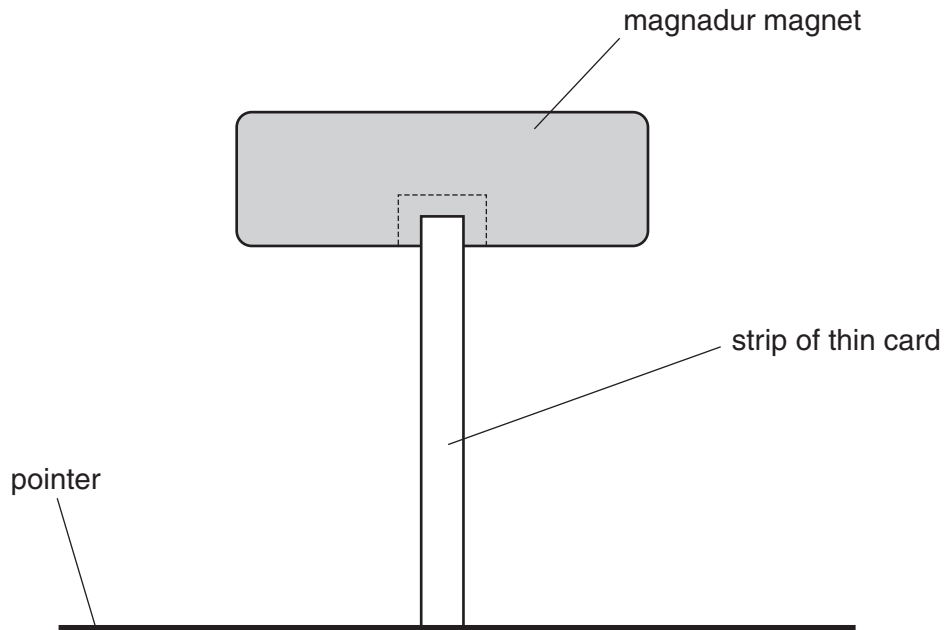

**Fig. 1.3**

This nylon monofilament (e.g. thin fishing line) of length about 60 cm. If a thin nylon monofilament is unavailable, then cotton thread is an acceptable alternative.

Ammeter (range 0–5 A)

Low voltage power supply unit capable of supplying currents up to about 5 A. The output of this supply must be continuously adjustable in this range.

Switch

Sufficient connecting leads in order that candidates are able to connect the circuit shown in Fig. 1.4.

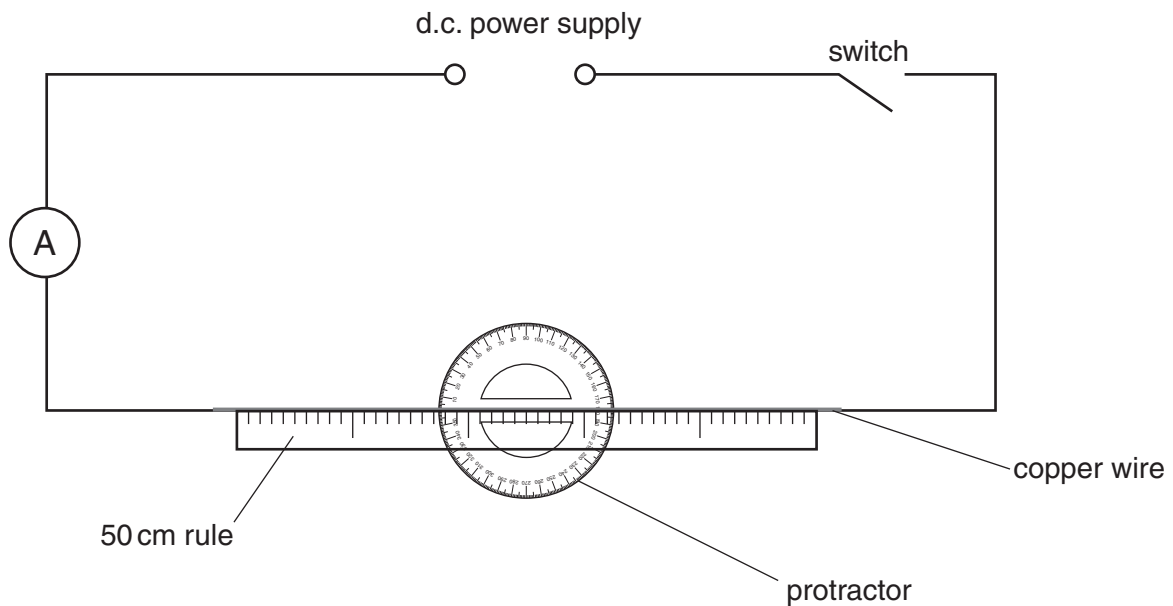
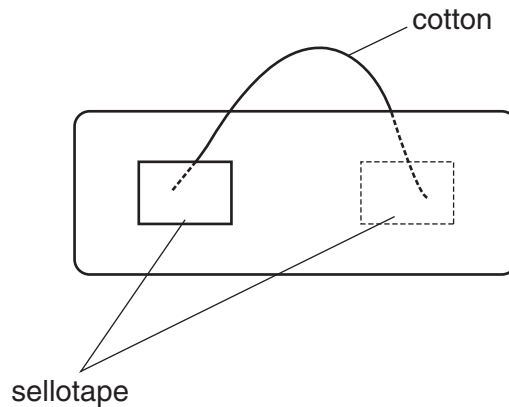

**Fig. 1.4**

The circuit should not be connected.

## Notes

- 1 The magnet and pointer should be suspended from the nylon filament (or cotton thread) by attaching it to a loop of cotton which has been sellotaped to both sides of the magnet, as shown in Fig. 1.5.



**Fig. 1.5**

The pointer should lie in a horizontal plane. When the rule and protractor are placed below the pointer, the distance from the plane of the protractor to the pointer should be not more than about 3mm to reduce parallax error. The magnet will align itself so that the plane of the magnet lies roughly in an East-West direction. It will not matter if this is slightly different from station to station. See Fig. 1.6.

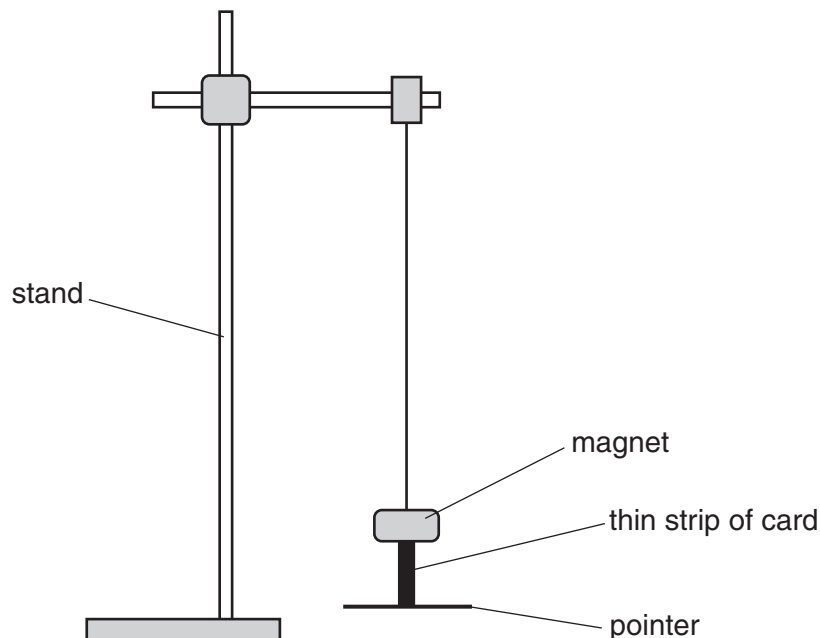

**Fig. 1.6**

- 2 Supervisors must trial the experiment beforehand to ensure that a current of about 5 A in the copper wire produces a deflection of more than 30°. If necessary the length of the card should be reduced and the magnet lowered in order to achieve this.

- 3 If the apparatus is to be used by a second candidate, the circuit should be dismantled at the end of the first candidate's experiment and the equipment laid out on the bench ready for the next candidate to use.
- 4 At the beginning of the experiment, Supervisors must be particularly vigilant to ensure that candidates have connected the circuit correctly and that the pointer is initially perpendicular to the copper wire. The extent of any help given must be reported in the usual way and sent with the scripts.

### **Procedure to be followed by candidates**

Candidates will place the rule and protractor onto a sheet of white paper below the suspended magnet so that the centre of the protractor is directly below the point of suspension of the magnet and the pointer reads  $90^\circ$  and  $270^\circ$ . Candidates will use the circuit of Fig. 1.4 to vary the current  $I$  in the wire and take readings of the deflection  $\theta$  of the pointer.

A graph of  $\tan \theta$  against  $I$  should give a straight line with a positive gradient which passes through the origin.

### **Question 2**

Question 2 is a design exercise which does not require apparatus.

This form should be completed and sent to the Examiner with the scripts.

## REPORT ON PRACTICAL PHYSICS

### General Certificate of Education Advanced Level

May/June Session 2003

#### General

The Supervisor is invited to give details, on the reverse of this form, of any difficulties experienced by particular candidates, giving names and index numbers. These should include reference to:

- (a) accidents to apparatus or materials;
- (b) any other information that is likely to assist the examiner, especially if this cannot be discovered in the scripts;
- (c) any help given to a candidate.

Other cases of individual hardship, e.g. illness, disability, should be reported direct to CIE on the normal 'Special Consideration Form'.

In cases of faulty apparatus (not arising from a candidate's mishandling) which prevent the required readings being taken, the following action is permissible.

The Invigilator – in consultation with the Physics teacher responsible for preparing the examination – may allow extra time to give the candidate a fair opportunity of performing the experiment as if the fault had not been present. The candidate should use a spare copy of the Question Paper when the fault has been rectified or when working with a second set of apparatus. The Invigilator is asked to provide CIE with details of such cases of time compensation (a copy being enclosed with the scripts), especially

- (i) the candidate's name and index number,
- (ii) the extra time allowed,
- (iii) notes on the nature of the fault, the action taken to rectify the difficulty and any other comments which would be helpful to the Examiner in making a fair assessment of the candidate's work during the practical examination.



**Information required**

A list, by name and index number, of candidates requiring help, with details of help provided

**Declaration** (to be signed by the Principal)

The preparation of this practical examination has been carried out so as to maintain fully the security of the examination.

Signed .....

Centre Number .....

Name of Centre .....

