



UNIVERSITY OF CAMBRIDGE INTERNATIONAL EXAMINATIONS
 General Certificate of Education
 Advanced Subsidiary Level and Advanced Level

CANDIDATE
 NAME

CENTRE
 NUMBER

--	--	--	--	--

CANDIDATE
 NUMBER

--	--	--	--



PHYSICS

9702/31

Paper 31 Advanced Practical Skills 1

May/June 2009

2 hours

Candidates answer on the Question Paper.

Additional Materials: As listed in the Confidential Instructions.

READ THESE INSTRUCTIONS FIRST

Write your Centre number, candidate number and name on all work you hand in.

Write in dark blue or black pen.

You may use a soft pencil for any diagrams, graphs or rough working.

Do not use staples, paper clips, highlighters, glue or correction fluid.

DO **NOT** WRITE IN ANY BARCODES.

Answer **both** questions.

You will be allowed to work with the apparatus for a maximum of one hour for each question.

You are expected to record all your observations as soon as these observations are made, and to plan the presentation of the records so that it is not necessary to make a fair copy of them. The working of the answers is to be handed in.

Additional answer paper and graph paper should be used only if it becomes necessary to do so.

You are reminded of the need for good English and clear presentation in your answers.

At the end of the examination, fasten all your work securely together.

All questions in this paper carry equal marks.

For Examiner's Use	
1	
2	
Total	

This document consists of **10** printed pages and **2** blank pages.



You may not need to use all of the materials provided.

For
Examiner's
Use

- 1 In this experiment you will investigate how the current in a circuit depends on the arrangement of resistors within the circuit. You have been provided with four $47\ \Omega$ resistors and one unknown resistor.
- (a) Connect the unknown resistor, labelled X, in series with the four $47\ \Omega$ resistors, an ammeter, a battery and a switch, as shown in Fig. 1.1.

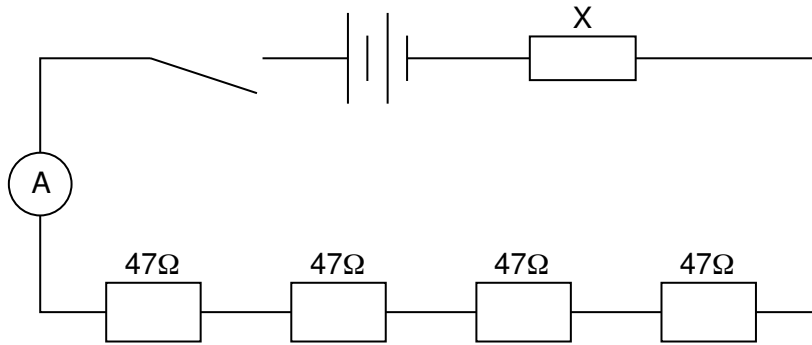

Fig. 1.1

Close the switch and record the current I in the circuit. Immediately after taking the reading, open the switch.

$I = \dots\dots\dots$ A

- (b) Fig. 1.2 shows a number of possible combinations of the 47Ω resistors, together with values of their combined resistance R .

For
Examiner's
Use

Resistor arrangement	R/Ω
	12
	16
	24
	47
	71
	94
	118
	141
	188

Fig. 1.2

From Fig. 1.2, select six combinations of resistors. Connect each combination in turn in the circuit of Fig. 1.1, keeping resistor X in the same place. Measure and record the current I for each of your combinations.

For
Examiner's
Use

Include in your table the values of R and $\frac{1}{I}$.

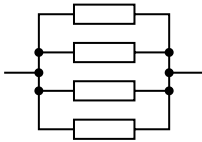
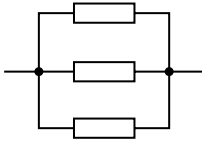
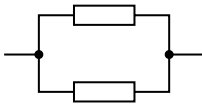
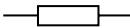
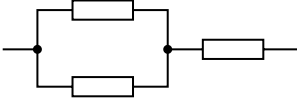
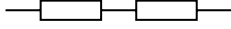
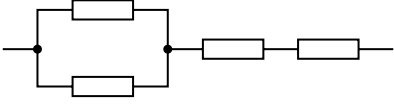
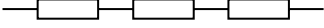
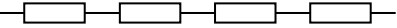
--

--

--

--

--

- (c) (i) Plot a graph of $\frac{1}{I}$ on the y -axis against R on the x -axis. Draw the line of best fit.
(ii) Determine the gradient and y -intercept of this line.

gradient =

y -intercept =

For
Examiner's
Use

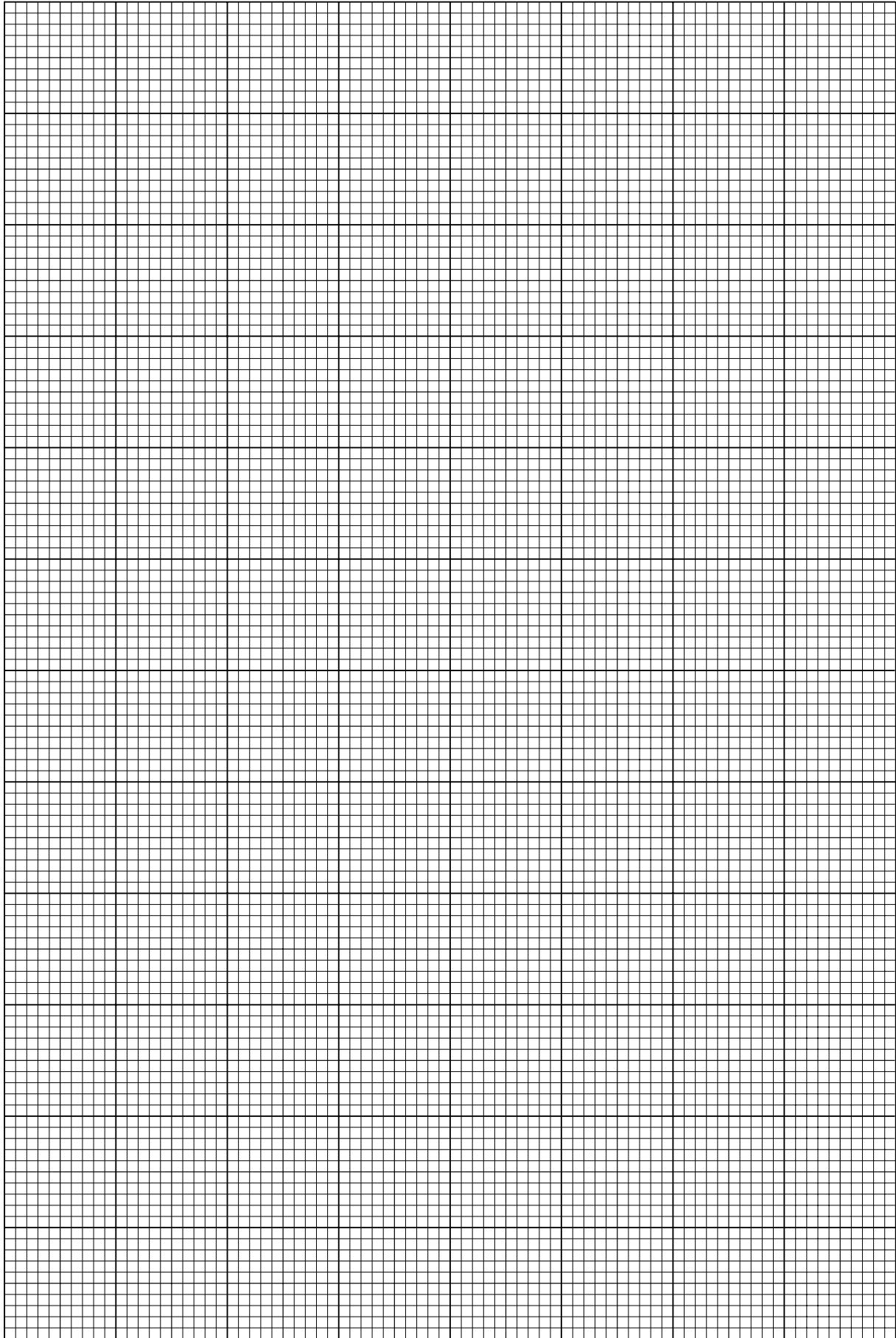

(d) It is suggested that the relationship between I and R is

$$\frac{1}{I} = \frac{R}{P} + \frac{Q}{P}$$

where P and Q are constants.

Use your answers from (c)(ii) to determine values for P and Q . Give appropriate units.

For
Examiner's
Use

$P =$

$Q =$

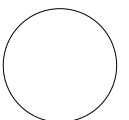

You may not need to use all of the materials provided.

For
Examiner's
Use

2 In this experiment you will investigate the angle of tilt of a bottle when it contains different amounts of water.

(a) (i) Use the water supplied to measure the volume of the bottle. (1 ml = 1 cm³)

volume of container = cm³

(ii) Justify the number of significant figures you have given for the volume of the bottle.

.....
.....
.....

(b) Add water to the empty bottle until it is about half-full.

(i) Measure the height h as shown in Fig. 2.1.

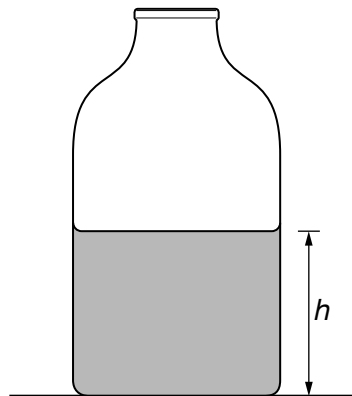

Fig. 2.1

h = cm

- (ii) The angle of tilt θ of the bottle is the angle it makes with the horizontal when it is about to topple, as shown in Fig. 2.2.

For
Examiner's
Use

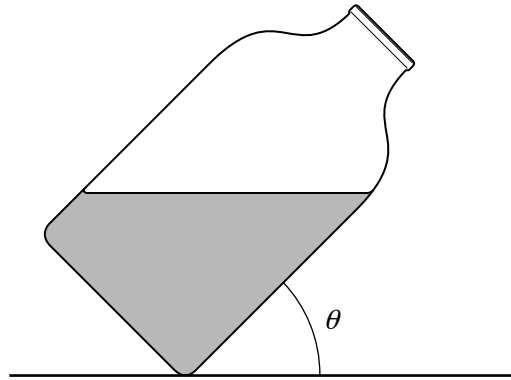

Fig. 2.2

Making sure that the lid is secure, tilt the bottle as shown, until it is about to topple, and measure θ .

$\theta = \dots\dots\dots^\circ$

- (iii) Estimate the percentage uncertainty in θ .

percentage uncertainty = $\dots\dots\dots$

- (iv) Measure the volume V of the water in the bottle.

$V = \dots\dots\dots \text{cm}^3$

- (c) Empty the water from the bottle. Refill the bottle so that it is about a quarter-full and repeat (b)(i), (b)(ii) and (b)(iv).

For
Examiner's
Use

$h = \dots\dots\dots$ cm

$\theta = \dots\dots\dots$ °

$V = \dots\dots\dots$ cm³

- (d) It is suggested that \sqrt{h} is inversely proportional to $\cos\theta$. Explain whether the results of your experiment support this idea.

.....

.....

.....

.....

.....

(e) (i) State four sources of error or limitations of the procedure in this experiment.

- 1.
.....
- 2.
.....
- 3.
.....
- 4.
.....

(ii) Suggest four improvements that could be made to this experiment. You may suggest the use of other apparatus or different procedures.

- 1.
.....
- 2.
.....
- 3.
.....
- 4.
.....

For
Examiner's
Use

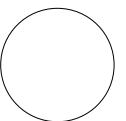

Permission to reproduce items where third-party owned material protected by copyright is included has been sought and cleared where possible. Every reasonable effort has been made by the publisher (UCLES) to trace copyright holders, but if any items requiring clearance have unwittingly been included, the publisher will be pleased to make amends at the earliest possible opportunity.

University of Cambridge International Examinations is part of the Cambridge Assessment Group. Cambridge Assessment is the brand name of University of Cambridge Local Examinations Syndicate (UCLES), which is itself a department of the University of Cambridge.