



UNIVERSITY OF CAMBRIDGE INTERNATIONAL EXAMINATIONS  
General Certificate of Education  
Advanced Subsidiary Level and Advanced Level

---

**PHYSICS**

**9702/35**

Advanced Practical Skills 1

**October/November 2010**

CONFIDENTIAL INSTRUCTIONS



**Great care should be taken to ensure that any confidential information given does not reach the candidates either directly or indirectly.**

**No access to the Question Paper is permitted in advance of the examination.**

---

If you have any problems or queries regarding these Instructions, please contact CIE  
by e-mail: [international@cie.org.uk](mailto:international@cie.org.uk),  
by phone: +44 1223 553554,  
by fax +44 1223 553558,  
stating the Centre number, the nature of the query and the syllabus number quoted above.

---

This document consists of **7** printed pages and **1** blank page.



## Preparing apparatus

These instructions detail the apparatus required for the experiments in the Question Paper. It is essential that absolute confidentiality is maintained in advance of the examination: the contents of these instructions must not be revealed either directly or indirectly to candidates.

No access is permitted to the Question Paper in advance of the examination.

If you have problems or queries regarding these instructions, please contact CIE:

by e-mail: international@cie.org.uk,

or by telephone: +44 1223 553554,

or by fax: +44 1223 553558,

stating the nature of the query and quoting the syllabus and paper numbers (9702/35).

It is assumed that the ordinary apparatus of a Physics laboratory will be available.

## Number of sets of apparatus

The number of sets of apparatus provided for each experiment should be  $\frac{1}{2}N$ , where  $N$  is the number of candidates taking the examination. There should, in addition, be a few spare sets of apparatus available in case problems arise during the examination.

## Organisation of the examination

Candidates should be allowed access to the apparatus for each experiment for one hour only. After spending one hour on one experiment, candidates should change over to the other experiment. The order in which a candidate attempts the two experiments is immaterial.

## Assistance to Candidates

Candidates should be informed that, if they find themselves in real difficulty, they may ask the Supervisor for practical assistance, but that the extent of this assistance will be reported to the Examiner, who may make a deduction of marks.

Assistance should only be given:

when it is asked for by a candidate,

or as directed in the Notes sections of these instructions,

or where apparatus is seen to have developed a fault.

Assistance should be restricted to enabling candidates to make observations and measurements. Observations and measurements must not be made for candidates, and no help should be given with data analysis or evaluation.

All assistance given to candidates must be reported on the Supervisor's Report Form.

## Faulty apparatus

In cases of faulty apparatus (not arising from a candidate's mishandling) that prevent the required measurements being taken, the Supervisor may allow extra time to give the candidate a fair opportunity to perform the experiment as if the fault had not been present. The candidate should use a spare copy of the Question Paper when the fault has been rectified or when working with a second set of apparatus.

## Supervisor's Report

The Supervisor should complete the Supervisor's Report Form on pages 7 and 8 and enclose it in the envelope containing the answers of the candidates. If more than one envelope is used, a copy of the report must be enclosed in each envelope.

**Question 1****Apparatus requirements (per set of apparatus unless otherwise specified)**

1 V – 2 V d.c. power supply (such as a 1.5 V dry cell in holder) with terminals.

Metre rule with a millimetre scale.

Set square.

110 cm length of 28 swg constantan wire. See Note 1 and Note 2.

20 cm length of 28 swg constantan wire taped to a card and labelled ‘sample of constantan wire’. See Note 2 and Note 3.

Plotting compass.

10  $\Omega$  resistor, with a power rating of at least 0.5 W and a tolerance of at most 5 % (e.g. Rapid Electronics product code 62-0518). The resistor should be mounted in a component holder with terminals and labelled ‘R’. Its resistance should be written on a card in the form

Resistance  $R$  of the fixed resistor = 10  $\Omega$ .

Digital ammeter or multimeter fixed to the range 0–200 mA, reading to at least the nearest 1 mA.

Switch.

Five connecting wires. Two of the wires should have a crocodile clip attached to one end. One of these crocodile clips should be labelled ‘Y’.

Access to a micrometer screw gauge.

**Notes**

- 1 The 110 cm length of wire should be attached to the metre rule with 5 cm protruding at each end. It should be possible to attach a crocodile clip to each end of the wire. The wire should be taped at each end firmly enough to minimise any looseness or kinks.
- 2 28 swg constantan wire is preferable. However, if this is unavailable, 30 swg constantan wire may be used. Alternatively 24 swg nichrome or 26 swg nichrome may be used.
- 3 If nichrome wire is used, the label should instead read ‘sample of nichrome wire’.
- 4 If the apparatus is to be used by another candidate, then it should be restored to its original state.

**Information required by Examiners**

Type of wire used (e.g. 28 swg constantan).

Sample set of numerical results, clearly labelled “Supervisor’s Results” and obtained out of sight of the candidates.

**Question 2****Apparatus requirements (per set of apparatus unless otherwise specified)**

Wooden metre rule with a millimetre scale. See Note 1.

Round flat-headed nail approximately 5 cm long and approximately 2.2 mm diameter. See Note 2.

Thin string. See Note 3.

Two 10 g mass hangers and nine 10 g slotted masses. See Note 4.

One retort stand and boss (to support nail). See Note 2.

30 cm ruler with a millimetre scale.

Protractor.

Pulley of approximate diameter 4 cm, attached to another retort stand. See Note 5.

Stopwatch reading to 0.1 s or better.

**Notes**

- 1 An alternative would be a piece of wood (with cross-sectional area similar to that of a metre rule) of length between 50 cm and 100 cm. The metre rule or piece of wood should have two 2.5 mm diameter holes: one drilled at its centre, and one drilled 1 cm from one end.
- 2 The metre rule should be pivoted on the nail, which should be firmly mounted in a boss 50 cm above the bench, as shown in Fig. 2.1. Ensure that the metre rule can swing freely and that the head of the nail prevents the rule falling off.
- 3 Two pieces of string should be provided:
  - a loop of approximately 10 cm, as shown in Fig. 2.2, laid separately on the bench;
  - a length of no more than approximately 40 cm, with one end tied through the hole at the end of the metre rule, and a small loop at the other end to accommodate the hook of a mass hanger.
- 4 The mass of the mass hangers and the slotted masses must be clearly visible.
- 5 The pulley should initially be attached at a height of approximately 40 cm above the bench, but this height should be adjustable by the candidate.
- 6 If the apparatus is to be used by another candidate, then it should be restored to its original state.

5

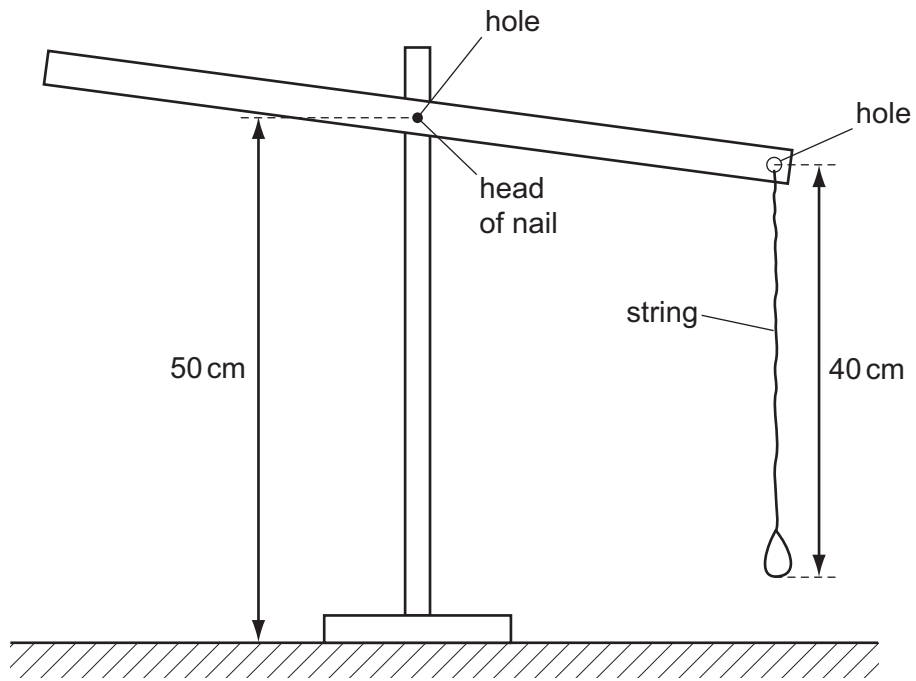

Fig. 2.1

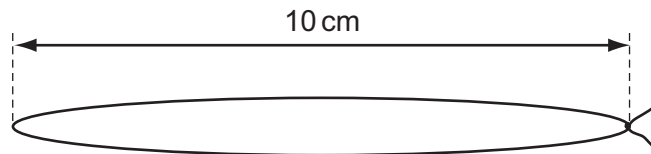

Fig. 2.2

**Information required by Examiners**

Sample set of numerical results, clearly labelled "Supervisor's Results" and obtained out of sight of the candidates.

**BLANK PAGE**

---

Permission to reproduce items where third-party owned material protected by copyright is included has been sought and cleared where possible. Every reasonable effort has been made by the publisher (UCLES) to trace copyright holders, but if any items requiring clearance have unwittingly been included the publisher will be pleased to make amends at the earliest possible opportunity.

University of Cambridge International Examinations is part of the Cambridge Assessment Group. Cambridge Assessment is the brand name of University of Cambridge Local Examinations Syndicate (UCLES), which is itself a department of the University of Cambridge.

This form should be completed and sent to the Examiner with the scripts.

### SUPERVISOR'S REPORT FORM

#### General Certificate of Education Advanced Subsidiary Level and Advanced Level

#### October/November Session 2010

The Supervisor's Report should give full details of:

- (a) any help given to a candidate (including the nature of the help given and the name and candidate number of the candidate);
- (b) any cases of faulty apparatus (including the nature of the problem, the action taken to rectify it, any additional time allowed, and the name and candidate number of the candidate);
- (c) any accidents that occurred during the examination;
- (d) any other difficulties experienced by candidates, or any other information that is likely to assist the Examiner, especially if this information cannot be discovered in the scripts.

Cases of individual hardship, such as illness, bereavement or disability, should be reported direct to CIE on the normal Special Consideration form.

#### Information required by Examiners

Type of wire used in Question 1 (e.g. 28 swg constantan): .....

For each question, please enclose a sample set of numerical results, obtained out of sight of the candidates and clearly labelled "Supervisor's Results".

#### Supervisor's Report



**Supervisor's Report (continued)**

**Declaration**

(to be signed by the Supervisor)

The preparation of this practical examination has been carried out so as to maintain fully the security of the examination.

Signed .....

Name .....

Centre Number .....

Name of Centre .....

