

CANDIDATE  
NAME

--

CENTRE  
NUMBER

--	--	--	--	--

CANDIDATE  
NUMBER

--	--	--	--

**BIOLOGY**

**9700/31**

Advanced Practical Skills 1

**October/November 2014**

**2 hours**

Candidates answer on the Question Paper.

Additional Materials: As listed in the Confidential Instructions.

**READ THESE INSTRUCTIONS FIRST**

Write your Centre number, candidate number and name on all the work you hand in.

Write in dark blue or black pen.

You may use an HB pencil for any diagrams or graphs.

Do **not** use staples, paper clips, glue or correction fluid.

DO **NOT** WRITE IN ANY BARCODES.

Answer **all** questions.

Electronic calculators may be used.

You may lose marks if you do not show your working or if you do not use appropriate units.

At the end of the examination, fasten all your work securely together.

The number of marks is given in brackets [ ] at the end of each question or part question.

For Examiner's Use	
1	
2	
Total	

This document consists of **13** printed pages and **3** blank pages.



Before you proceed, read carefully through **the whole** of Question 1 and Question 2.

Plan the use of your **time** to make sure that you finish all the work that you would like to do.

If you have enough time, consider how you can improve the accuracy of your results, for example by obtaining and recording one or more additional measurements.

You will **gain marks** for recording your results according to the instructions.

**1** An enzyme, **E**, catalyses the hydrolysis (breakdown) of triglycerides into fatty acids and glycerol.

The substrate for **E** will be the triglycerides present in milk, labelled **M**.

The end-point of this hydrolysis can be determined by using an indicator, **I**, which changes colour when the fatty acids are produced, as shown in Fig. 1.1.



end-point

**Fig. 1.1**

You are required to:

- prepare different concentrations of the enzyme solution, **E**
- investigate the effect of different concentrations of **E** (independent variable) on the hydrolysis of triglycerides in milk.

You are provided with:

labelled	contents	hazard	volume / cm <sup>3</sup>
<b>M</b>	milk	none	40
<b>W</b>	distilled water	none	50
<b>I</b>	indicator solution	stains	30
<b>A</b>	solution of alkali	irritant	40
<b>E</b>	5% enzyme solution	irritant	50

You are required to dilute the 5% enzyme solution, **E**, to provide a range of known concentrations using **simple** dilution.

Decide on the further concentrations of enzyme solution you will use in your investigation in addition to the 5% solution.

You will need to use 10 cm<sup>3</sup> of each enzyme solution.

**(a) (i)** Prepare the space below to show:

- the concentration of each **enzyme solution**
- the volumes of **E**
- the volumes of **W**.

[3]

**(ii)** Describe the expected trend in the time taken to reach the end-point as the concentration of enzyme solution increases.

.....  
.....[1]

**(iii)** State **one** reason for the expected trend described in **(a)(ii)**.

.....  
.....[1]

- (iv) As part of this investigation you are required to set up a control using the apparatus provided.

Describe how you will set up this control.

.....  
 .....  
 .....[1]

*Read step 1 to step 10 before proceeding.*

Proceed as follows:

1. Prepare **all** the concentrations of enzyme solutions you have listed in (a)(i) in the containers provided.

You are required to investigate the effect of different concentrations of enzyme solutions on the hydrolysis of triglycerides in milk. The appearance of fatty acids can be detected by using the indicator solution **I**.

2. Put 2 cm<sup>3</sup> of **M** into each of six separate test-tubes.
3. Put 2 cm<sup>3</sup> of **I** into each test-tube containing **M** and gently shake.
4. Put 3 cm<sup>3</sup> of **A** into each test-tube containing **M** and **I** and gently shake so that all the mixture turns orange.

*Note that the mixtures might be different shades of orange.*

The reaction will start as soon as you add enzyme solution, so read steps 5 to 10 before proceeding.

5. Set up your control as described in (a)(iv).
6. Put 2 cm<sup>3</sup> of the lowest concentration of enzyme solution into one of the test-tubes from step 4 and mix well.
7. Repeat step 6 with **two** other concentrations of enzyme solution.
8. Start timing.
9. Record the time when each end-point (yellow) is reached, as shown in Fig. 1.1.
10. Repeat steps 6, 8 and 9 with the remaining concentrations of enzyme solution.

If the time taken to reach the end-point for any one concentration is longer than 300 seconds (5 minutes) **record** as 'more than 300'.

(v) Prepare the space below to record your results.

[5]

(vi) Calculate the rate of hydrolysis for the 5% E.

..... s<sup>-1</sup> [1]

(vii) Identify **one significant** source of error in measuring the dependent variable in the investigation you have just carried out.

.....  
.....  
.....[1]

(viii) You used a syringe to measure the volumes of **M**.

State the volume of the smallest division on the syringe .....

State the actual error of the syringe.

actual error .....  
[1]

(b) Suggest how you would modify this investigation to obtain an accurate optimum temperature for the activity of **E**.

.....  
.....  
.....  
.....  
.....  
.....  
.....  
.....[3]

[Total: 17]

**Question 2 starts on page 8**

You are required to use a sharp pencil for drawings and graphs.

- 2 **J1** is a slide of a stained transverse section through a plant stem. This plant species grows widely including Europe, Asia and northwest Africa. You are not expected to be familiar with this specimen.

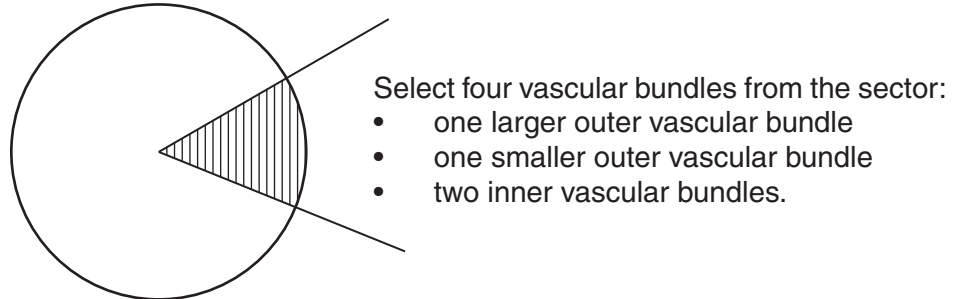

**Fig. 2.1**

- (a) (i) Draw a large plan diagram of the part of the specimen on **J1** indicated by the shaded sector in Fig. 2.1. Your plan diagram should include:
- the part of the specimen indicated by the shaded sector
  - the four vascular bundles which you selected from the sector.
- Use **one** ruled label line and label to show **one** vascular bundle.



(ii) Observe the tissue in the central pith.

Select one group of three whole cells, which includes:

- one large cell
- two smaller cells which touch each other and also touch the large cell.

Make a large drawing of the group of cells which you have selected.

Use **one** ruled label line and label to show **one** cell wall.

[5]

- (b) Fig. 2.2 is a photomicrograph of a stained transverse section through a stem of a different plant species.  
This plant species is found globally.

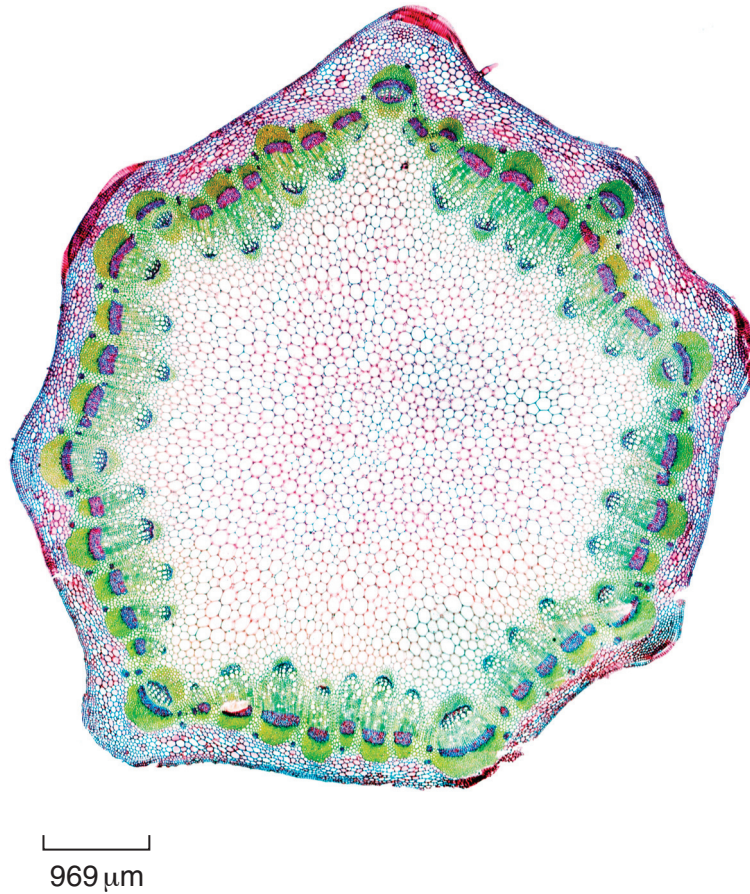

**Fig. 2.2**

- (i) Calculate the magnification of Fig. 2.2 using the scale bar.  
You may lose marks if you do not show your working or if you do not use appropriate units.

magnification × ..... [3]

- (ii) Prepare the space below so that it is suitable for you to show the observable differences between the specimens shown on **J1** and on Fig 2.2.

Record your observations in the space you have prepared.

[4]

- (c) A student investigated the effect of different concentrations of sucrose solutions on 5 pieces of plant stem.

At the start, each piece of plant stem was cut along part of its length as shown in Fig. 2.3.

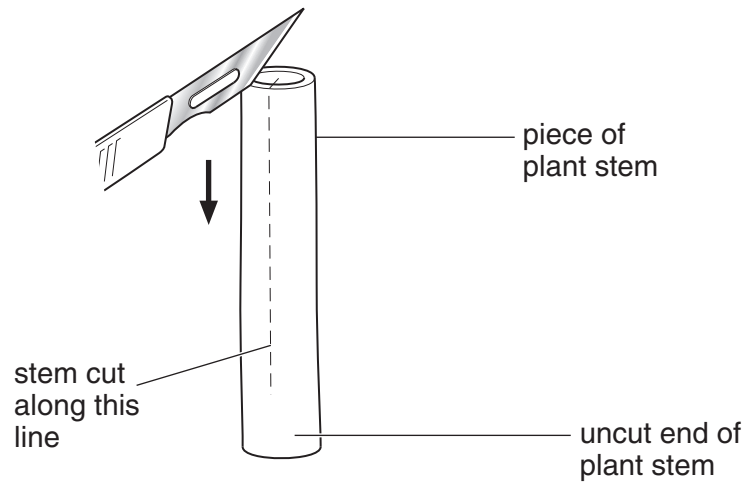

**Fig. 2.3**

Each piece of cut plant stem curved as shown in Fig. 2.4. The distance between the cut ends was 10 mm for each piece of plant stem.

Each piece of plant stem was placed in a separate dish as shown in Fig. 2.4 and covered with the same volume of one of the concentrations of sucrose solution. A different concentration of sucrose solution was used in each of the five dishes.

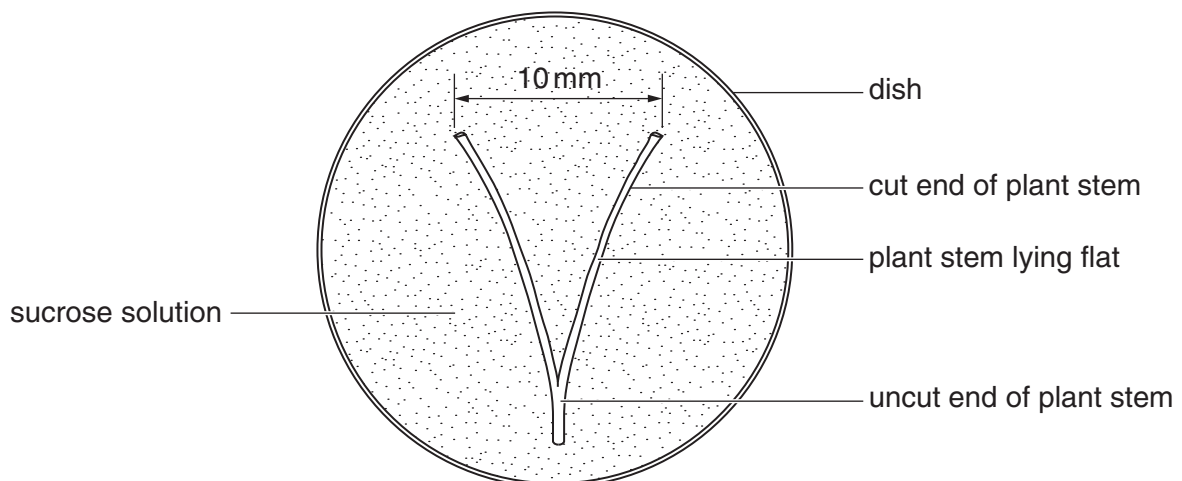

**Fig. 2.4**

After a set time the distance between the cut ends was measured for each piece of plant stem.

The student calculated the change in distance between the cut ends for each plant stem.







---

*Copyright Acknowledgements:*

Question 2 Fig 2.2 © DR KEITH WHEELER/SCIENCE PHOTO LIBRARY

Permission to reproduce items where third-party owned material protected by copyright is included has been sought and cleared where possible. Every reasonable effort has been made by the publisher (UCLES) to trace copyright holders, but if any items requiring clearance have unwittingly been included, the publisher will be pleased to make amends at the earliest possible opportunity.

Cambridge International Examinations is part of the Cambridge Assessment Group. Cambridge Assessment is the brand name of University of Cambridge Local Examinations Syndicate (UCLES), which is itself a department of the University of Cambridge.