

**CAMBRIDGE INTERNATIONAL EXAMINATIONS**  
**General Certificate of Education Advanced Subsidiary Level**  
**General Certificate of Education Advanced Level**

**HIGHER MATHEMATICS**  
**MATHEMATICS**  
**PAPER 5 Mechanics 2 (M2)**

**8719/5**  
**9709/5**

**MAY/JUNE SESSION 2002**

1 hour 15 minutes

Additional materials:  
Answer paper  
Graph paper  
List of Formulae (MF9)

**TIME** 1 hour 15 minutes

**INSTRUCTIONS TO CANDIDATES**

Write your name, Centre number and candidate number in the spaces provided on the answer paper/answer booklet.

Answer **all** the questions.

Give non-exact numerical answers correct to 3 significant figures, or 1 decimal place in the case of angles in degrees, unless a different level of accuracy is specified in the question.

Where a numerical value for the acceleration due to gravity is needed, use  $10 \text{ m s}^{-2}$ .

**INFORMATION FOR CANDIDATES**

The number of marks is given in brackets [ ] at the end of each question or part question.

The total number of marks for this paper is 50.

Questions carrying smaller numbers of marks are printed earlier in the paper, and questions carrying larger numbers of marks later in the paper.

The use of an electronic calculator is expected, where appropriate.

You are reminded of the need for clear presentation in your answers.

---

**This question paper consists of 4 printed pages.**

- 1 One end of a light elastic string of natural length 1.6 m and modulus of elasticity 25 N is attached to a fixed point  $A$ . A particle  $P$  of mass 0.15 kg is attached to the other end of the string.  $P$  is held at rest at a point 2 m vertically below  $A$  and is then released.

(i) For the motion from the instant of release until the string becomes slack, find the loss of elastic potential energy and the gain in gravitational potential energy. [3]

(ii) Hence find the speed of  $P$  at the instant the string becomes slack. [2]

2

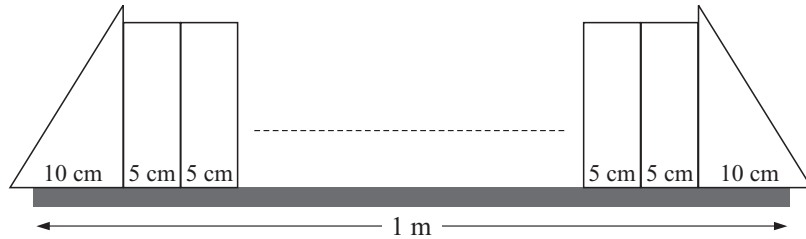

Two identical uniform heavy triangular prisms, each of base width 10 cm, are arranged as shown at the ends of a smooth horizontal shelf of length 1 m. Some books, each of width 5 cm, are placed on the shelf between the prisms.

(i) Find how far the base of a prism can project beyond an end of the shelf without the prism toppling. [2]

(ii) Find the greatest number of books that can be stored on the shelf without either of the prisms toppling. [2]

3

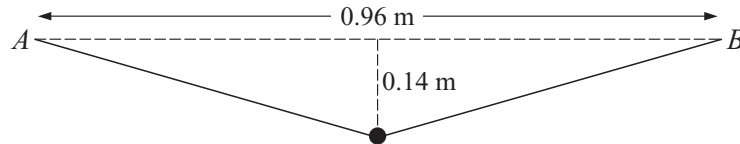

A light elastic string has natural length 0.8 m and modulus of elasticity 12 N. The ends of the string are attached to fixed points  $A$  and  $B$ , which are at the same horizontal level and 0.96 m apart. A particle of weight  $W$  N is attached to the mid-point of the string and hangs in equilibrium at a point 0.14 m below  $AB$  (see diagram). Find  $W$ . [5]

4

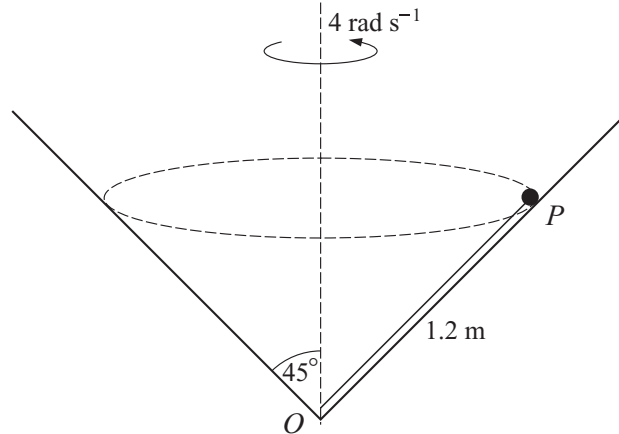

A hollow cone with semi-vertical angle  $45^\circ$  is fixed with its axis vertical and its vertex  $O$  downwards. A particle  $P$  of mass  $0.3\text{ kg}$  moves in a horizontal circle on the inner surface of the cone, which is smooth.  $P$  is attached to one end of a light inextensible string of length  $1.2\text{ m}$ . The other end of the string is attached to the cone at  $O$  (see diagram). The string is taut and rotates at a constant angular speed of  $4\text{ rad s}^{-1}$ .

(i) Find the acceleration of  $P$ . [2]

(ii) Find the tension in the string and the force exerted on  $P$  by the cone. [6]

5

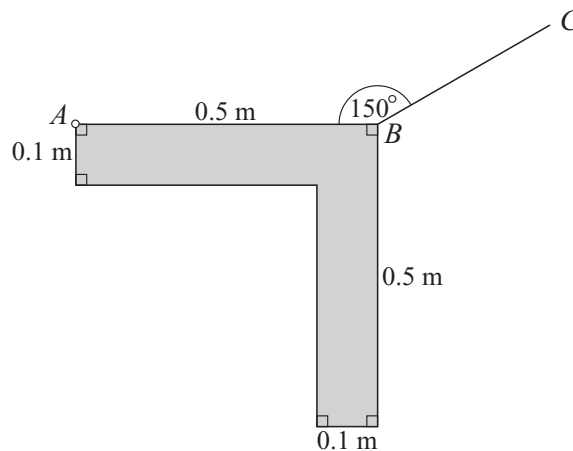

A uniform lamina of weight  $9\text{ N}$  has dimensions as shown in the diagram. The lamina is freely hinged to a fixed point at  $A$ . A light inextensible string has one end attached to  $B$ , and the other end attached to a fixed point  $C$ , which is in the same vertical plane as the lamina. The lamina is in equilibrium with  $AB$  horizontal and angle  $ABC = 150^\circ$ .

(i) Show that the tension in the string is  $12.2\text{ N}$ . [5]

(ii) Find the magnitude of the force acting on the lamina at  $A$ . [4]

6

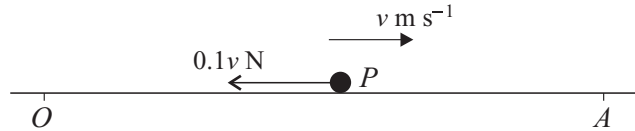

A particle  $P$  of mass  $0.4 \text{ kg}$  travels on a horizontal surface along the line  $OA$  in the direction from  $O$  to  $A$ . Air resistance of magnitude  $0.1v \text{ N}$  opposes the motion, where  $v \text{ m s}^{-1}$  is the speed of  $P$  at time  $t \text{ s}$  after it passes through the fixed point  $O$  (see diagram). The speed of  $P$  at  $O$  is  $2 \text{ m s}^{-1}$ .

(i) Assume that the horizontal surface is smooth. Show that  $\frac{dv}{dx} = -\frac{1}{4}$ , where  $x \text{ m}$  is the distance of  $P$  from  $O$  at time  $t \text{ s}$ , and hence find the distance from  $O$  at which the speed of  $P$  is zero. [4]

(ii) Assume instead that the horizontal surface is not smooth and that the coefficient of friction between  $P$  and the surface is  $\frac{3}{40}$ .

(a) Show that  $4\frac{dv}{dt} = -(v + 3)$ . [3]

(b) Hence find the value of  $t$  for which the speed of  $P$  is zero. [3]

7 A ball is projected from a point  $O$  with speed  $V \text{ m s}^{-1}$ , at an angle of  $30^\circ$  above the horizontal. At time  $T \text{ s}$  after projection, the ball passes through the point  $A$ , whose horizontal and vertically upward displacements from  $O$  are  $10 \text{ m}$  and  $2 \text{ m}$  respectively.

(i) By using the equation of the trajectory, or otherwise, find the value of  $V$ . [3]

(ii) Find the value of  $T$ . [2]

(iii) Find the angle that the direction of motion of the ball at  $A$  makes with the horizontal. [4]