

UNIVERSITY OF CAMBRIDGE INTERNATIONAL EXAMINATIONS
General Certificate of Education
Advanced Subsidiary Level and Advanced Level

HIGHER MATHEMATICS
MATHEMATICS

8719/03
9709/03

Paper 3 Pure Mathematics 3 **(P3)**

May/June 2004

1 hour 45 minutes

Additional materials: Answer Booklet/Paper
Graph paper
List of Formulae (MF9)

READ THESE INSTRUCTIONS FIRST

If you have been given an Answer Booklet, follow the instructions on the front cover of the Booklet.
Write your Centre number, candidate number and name on all the work you hand in.
Write in dark blue or black pen on both sides of the paper.
You may use a soft pencil for any diagrams or graphs.
Do not use staples, paper clips, highlighters, glue or correction fluid.

Answer **all** the questions.

Give non-exact numerical answers correct to 3 significant figures, or 1 decimal place in the case of angles in degrees, unless a different level of accuracy is specified in the question.
At the end of the examination, fasten all your work securely together.

The number of marks is given in brackets [] at the end of each question or part question.

The total number of marks for this paper is 75.

Questions carrying smaller numbers of marks are printed earlier in the paper, and questions carrying larger numbers of marks later in the paper.

The use of an electronic calculator is expected, where appropriate.

You are reminded of the need for clear presentation in your answers.

This document consists of **3** printed pages and **1** blank page.



1 Sketch the graph of $y = \sec x$, for $0 \leq x \leq 2\pi$. [3]

2 Solve the inequality $|2x + 1| < |x|$. [4]

3 Find the gradient of the curve with equation

$$2x^2 - 4xy + 3y^2 = 3,$$

at the point (2, 1). [4]

4 (i) Show that if $y = 2^x$, then the equation

$$2^x - 2^{-x} = 1$$

can be written as a quadratic equation in y . [2]

(ii) Hence solve the equation

$$2^x - 2^{-x} = 1. [4]$$

5 (i) Prove the identity

$$\sin^2 \theta \cos^2 \theta \equiv \frac{1}{8}(1 - \cos 4\theta). [3]$$

(ii) Hence find the exact value of

$$\int_0^{\frac{1}{3}\pi} \sin^2 \theta \cos^2 \theta \, d\theta. [3]$$

6 Given that $y = 1$ when $x = 0$, solve the differential equation

$$\frac{dy}{dx} = \frac{y^3 + 1}{y^2},$$

obtaining an expression for y in terms of x . [6]

7 (i) The equation $x^3 + x + 1 = 0$ has one real root. Show by calculation that this root lies between -1 and 0. [2]

(ii) Show that, if a sequence of values given by the iterative formula

$$x_{n+1} = \frac{2x_n^3 - 1}{3x_n^2 + 1}$$

converges, then it converges to the root of the equation given in part (i). [2]

(iii) Use this iterative formula, with initial value $x_1 = -0.5$, to determine the root correct to 2 decimal places, showing the result of each iteration. [3]

- 8 (i) Find the roots of the equation $z^2 - z + 1 = 0$, giving your answers in the form $x + iy$, where x and y are real. [2]
- (ii) Obtain the modulus and argument of each root. [3]
- (iii) Show that each root also satisfies the equation $z^3 = -1$. [2]

9 Let $f(x) = \frac{x^2 + 7x - 6}{(x - 1)(x - 2)(x + 1)}$.

- (i) Express $f(x)$ in partial fractions. [4]

- (ii) Show that, when x is sufficiently small for x^4 and higher powers to be neglected,

$$f(x) = -3 + 2x - \frac{3}{2}x^2 + \frac{11}{4}x^3. \quad [5]$$

10

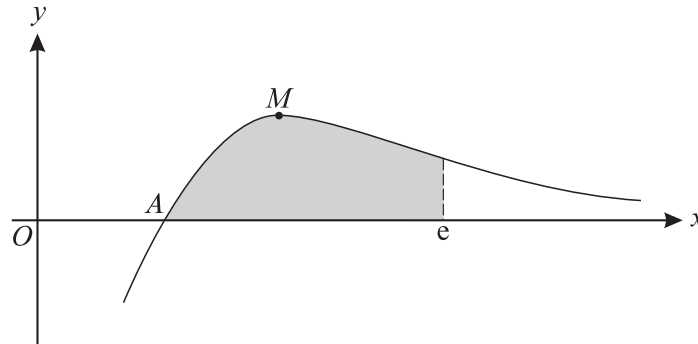

The diagram shows the curve $y = \frac{\ln x}{x^2}$ and its maximum point M . The curve cuts the x -axis at A .

- (i) Write down the x -coordinate of A . [1]
- (ii) Find the exact coordinates of M . [5]
- (iii) Use integration by parts to find the exact area of the shaded region enclosed by the curve, the x -axis and the line $x = e$. [5]
- 11 With respect to the origin O , the points P, Q, R, S have position vectors given by

$$\vec{OP} = \mathbf{i} - \mathbf{k}, \quad \vec{OQ} = -2\mathbf{i} + 4\mathbf{j}, \quad \vec{OR} = 4\mathbf{i} + 2\mathbf{j} + \mathbf{k}, \quad \vec{OS} = 3\mathbf{i} + 5\mathbf{j} - 6\mathbf{k}.$$

- (i) Find the equation of the plane containing P, Q and R , giving your answer in the form $ax + by + cz = d$. [6]
- (ii) The point N is the foot of the perpendicular from S to this plane. Find the position vector of N and show that the length of SN is 7. [6]

BLANK PAGE