



UNIVERSITY OF CAMBRIDGE INTERNATIONAL EXAMINATIONS
International General Certificate of Secondary Education

CANDIDATE
NAME

CENTRE
NUMBER

--	--	--	--	--

CANDIDATE
NUMBER

--	--	--	--



CHEMISTRY

0620/32

Paper 3 (Extended)

May/June 2010

1 hour 15 minutes

Candidates answer on the Question Paper.

No Additional Materials are required.

READ THESE INSTRUCTIONS FIRST

Write your Centre number, candidate number and name on all the work you hand in.

Write in dark blue or black pen.

You may use a pencil for any diagrams, graphs or rough working.

Do not use staples, paper clips, highlighters, glue or correction fluid.

DO NOT WRITE IN ANY BARCODES.

Answer **all** questions.

A copy of the Periodic Table is printed on page 16.

At the end of the examination, fasten all your work securely together.

The number of marks is given in brackets [] at the end of each question or part question.

For Examiner's Use	
1	
2	
3	
4	
5	
6	
7	
8	
Total	

This document consists of **13** printed pages and **3** blank pages.



1 For each of the following unfamiliar elements predict one physical and one chemical property.

(a) caesium (Cs)

physical property

chemical property

..... [2]

(b) vanadium (V)

physical property

chemical property

..... [2]

(c) fluorine (F)

physical property

chemical property

..... [2]

[Total: 6]

2 The hydrolysis of complex carbohydrates to simple sugars is catalysed by enzymes called carbohydrases and also by dilute acids.

(a) (i) They are both catalysts. How do enzymes differ from catalysts such as dilute acids?

..... [1]

(ii) Explain why ethanol, C_2H_6O , is not a carbohydrate but glucose, $C_6H_{12}O_6$, is a carbohydrate.

.....

..... [2]

(b) Draw the structure of a complex carbohydrate, such as starch. The formula of a simple sugar can be represented by $HO-\square-OH$.

[3]

(c) Iodine reacts with starch to form a deep blue colour.

(i) In the experiment illustrated below, samples are removed at intervals and tested with iodine in potassium iodide solution.

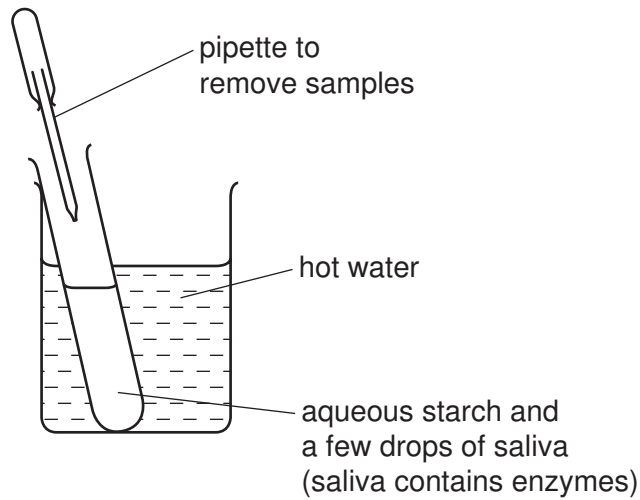

Typical results of this experiment are shown in the table.

time / min	colour of sample tested with iodine in potassium iodide solution
0	deep blue
10	pale blue
30	colourless

Explain these results.

.....

 [3]

(ii) If the experiment was repeated at a higher temperature, 60 °C, all the samples stayed blue. Suggest an explanation.

..... [1]

[Total: 10]

3 The following are examples of redox reactions.

(a) Bromine water was added to aqueous sodium sulfide.

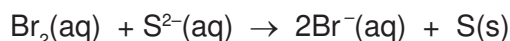

(i) Describe what you would observe when this reaction occurs.

.....
..... [2]

(ii) Write a symbol equation for this reaction.

..... [1]

(iii) Explain, in terms of electron transfer, why bromine is the oxidant (oxidising agent) in this reaction.

.....
..... [2]

(b) Iron and steel in the presence of water and oxygen form rust.

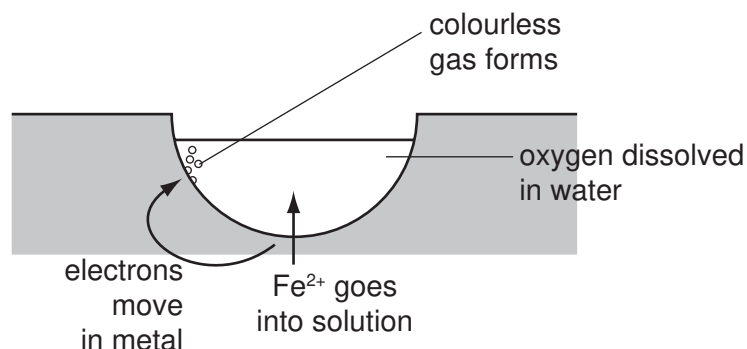

The reactions involved are:

reaction 1



The electrons move through the iron on to the surface where a colourless gas forms.

reaction 2

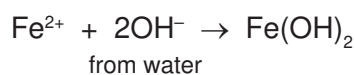

reaction 3

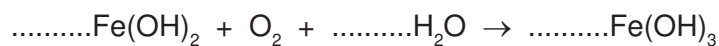

The water evaporates to leave rust.

- (i) What type of reaction is **reaction 1**? [1]
- (ii) Deduce the name of the colourless gas mentioned in **reaction 1**.
..... [1]
- (iii) What is the name of the iron compound formed in **reaction 2**?
..... [1]
- (iv) Balance the equation for **reaction 3**.
..... $\text{Fe}(\text{OH})_2 + \text{O}_2 + \text{.....H}_2\text{O} \rightarrow \text{.....Fe}(\text{OH})_3$ [1]
- (v) Explain why the change $\text{Fe}(\text{OH})_2$ to $\text{Fe}(\text{OH})_3$ is oxidation.
.....
..... [1]
- (vi) Explain why iron in electrical contact with a piece of zinc does not rust.
.....
.....
..... [3]

[Total: 13]

- 4 But-1-ene is a typical alkene. It has the structural formula shown below.

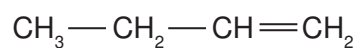

The structural formula of cyclobutane is given below.

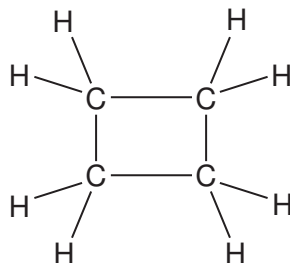

- (a) These two hydrocarbons are isomers.

- (i) Define the term *isomer*.

.....
..... [2]

(ii) Draw the structural formula of another isomer of but-1-ene.

[1]

(iii) Describe a test which would distinguish between but-1-ene and cyclobutane.

reagent

result with but-1-ene

.....

result with cyclobutane

..... [3]

(b) Describe how alkenes, such as but-1-ene, can be made from alkanes.

.....

..... [2]

(c) Name the product formed when but-1-ene reacts with:

bromine, [1]

hydrogen, [1]

steam. [1]

[Total: 11]

- 5 Fuel cells are used in spacecraft to produce electrical energy.

For
Examiner's
Use

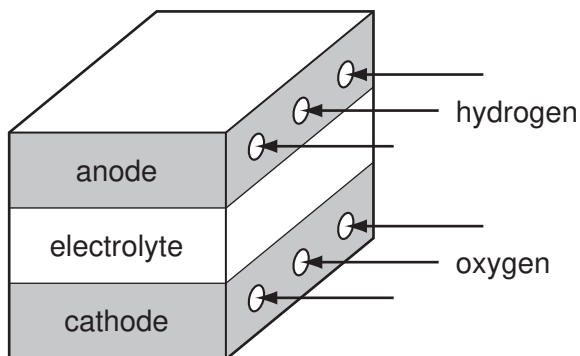

- (a) How is oxygen obtained from liquid air?

.....
..... [2]

- (b) Hydrogen and oxygen react to form water.

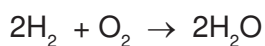

- (i) Give an example of bond breaking in the above reaction.

..... [1]

- (ii) Give an example of bond forming in the above reaction.

..... [1]

- (iii) Is the change given in (i) exothermic or endothermic?

..... [1]

- (c) (i) Give **two** reasons why hydrogen may be considered to be the ideal fuel for the future.

.....
.....
..... [2]

- (ii) Suggest a reason why hydrogen is not widely used at the moment.

.....
..... [1]

[Total: 8]

6 Thallium is a metal in Group III. It has oxidation states of +1 and +3.

(a) Give the formula for the following thallium compounds.

(i) thallium(I) sulfide [1]

(ii) thallium(III) chloride [1]

(b) Thallium(I) chloride is insoluble in water. Complete the description of the preparation of a pure sample of this salt.

Step 1

Mix a solution of sodium chloride with thallium(I) sulfate solution. A white precipitate forms.

Step 2

..... [1]

Step 3

..... [1]

Step 4

..... [1]

(c) When thallium(I) chloride is exposed to light, a photochemical reaction occurs. It changes from a white solid to a violet solid.

(i) Name another metal halide which changes colour when exposed to light. Give the major use of this metal halide.

name

use [2]

- (ii) A piece of paper coated with thallium(I) chloride is exposed to a bright light.

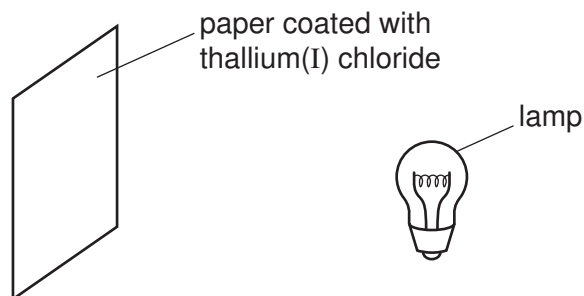

Suggest **two** ways of increasing the time it takes for the violet colour to appear.

.....

 [2]

- (d) Thallium(I) hydroxide is an alkali. It has similar properties to sodium hydroxide.

- (i) Complete the following word equation.

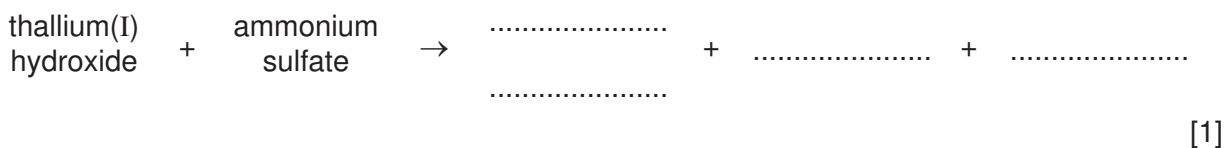

- (ii) Complete the equation.

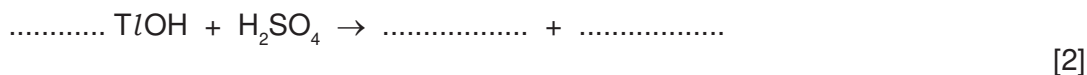

- (iii) Aqueous thallium(I) hydroxide was added to aqueous iron(II) sulfate. Describe what you would see and complete the ionic equation for the reaction.

observation [1]



[Total: 14]

7 Aluminium was first isolated in 1827 using sodium.

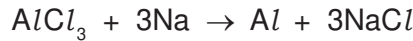

Aluminium, obtained by this method, was more expensive than gold.

(a) Suggest an explanation why aluminium was so expensive.

.....
..... [1]

(b) The modern method for extracting aluminium is the electrolysis of a molten electrolyte, aluminium oxide dissolved in cryolite. The aluminium oxide decomposes.

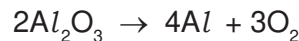

Both electrodes are made of carbon.

(i) Give **two** reasons why the oxide is dissolved in cryolite.

.....
.....
..... [2]

(ii) Complete the ionic equation for the reaction at the anode.



(iii) Why do the carbon anodes need to be replaced frequently?

.....
..... [1]

(c) The electrolysis of a molten electrolyte is one method of extracting a metal from its ore. Other methods are the electrolysis of an aqueous solution and the reduction of the oxide by carbon. Explain why these last two methods cannot be used to extract aluminium.

electrolysis of an aqueous solution

.....

using carbon

..... [2]

[Total: 8]

8 Nitrogen dioxide is a brown gas. It can be made by heating certain metal nitrates.



(a) (i) Name another metal whose nitrate decomposes to give the metal oxide, nitrogen dioxide and oxygen.

..... [1]

(ii) Complete the word equation for a metal whose nitrate does not give nitrogen dioxide on decomposition.

metal nitrate → + oxygen [1]

(b) At most temperatures, samples of nitrogen dioxide are equilibrium mixtures.

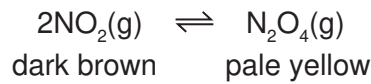

(i) At 25 °C, the mixture contains 20 % of nitrogen dioxide. At 100 °C this has risen to 90 %. Is the forward reaction exothermic or endothermic? Give a reason for your choice.

.....

 [2]

(ii) Explain why the colour of the equilibrium mixture becomes lighter when the pressure on the mixture is increased.

.....

 [2]

- (c) A 5.00 g sample of impure lead(II) nitrate was heated. The volume of oxygen formed was 0.16 dm³ measured at r.t.p. The impurities did not decompose. Calculate the percentage of lead(II) nitrate in the sample.



Number of moles of O₂ formed =

Number of moles of Pb(NO₃)₂ in the sample =

Mass of one mole of Pb(NO₃)₂ = 331 g

Mass of lead(II) nitrate in the sample = g

Percentage of lead(II) nitrate in sample =

[4]

[Total: 10]

DATA SHEET

The Periodic Table of the Elements

Group																					
I	II											III	IV	V	VI	VII	0				
										1 H Hydrogen 1											4 He Helium 2
7 Li Lithium 3	9 Be Beryllium 4											11 B Boron 5	12 C Carbon 6	14 N Nitrogen 7	16 O Oxygen 8	19 F Fluorine 9	20 Ne Neon 10				
23 Na Sodium 11	24 Mg Magnesium 12											27 Al Aluminium 13	28 Si Silicon 14	31 P Phosphorus 15	32 S Sulfur 16	35.5 Cl Chlorine 17	40 Ar Argon 18				
39 K Potassium 19	40 Ca Calcium 20	45 Sc Scandium 21	48 Ti Titanium 22	51 V Vanadium 23	52 Cr Chromium 24	55 Mn Manganese 25	56 Fe Iron 26	59 Co Cobalt 27	59 Ni Nickel 28	64 Cu Copper 29	65 Zn Zinc 30	70 Ga Gallium 31	73 Ge Germanium 32	75 As Arsenic 33	79 Se Selenium 34	80 Br Bromine 35	84 Kr Krypton 36				
85 Rb Rubidium 37	88 Sr Strontium 38	89 Y Yttrium 39	91 Zr Zirconium 40	93 Nb Niobium 41	96 Mo Molybdenum 42	96 Tc Technetium 43	101 Ru Ruthenium 44	103 Rh Rhodium 45	106 Pd Palladium 46	108 Ag Silver 47	112 Cd Cadmium 48	115 In Indium 49	119 Sn Tin 50	122 Sb Antimony 51	128 Te Tellurium 52	127 I Iodine 53	131 Xe Xenon 54				
133 Cs Caesium 55	137 Ba Barium 56	139 La Lanthanum 57 *	178 Hf Hafnium 72	181 Ta Tantalum 73	184 W Tungsten 74	186 Re Rhenium 75	190 Os Osmium 76	192 Ir Iridium 77	195 Pt Platinum 78	197 Au Gold 79	201 Hg Mercury 80	204 Tl Thallium 81	207 Pb Lead 82	209 Bi Bismuth 83	210 Po Polonium 84	210 At Astatine 85	210 Rn Radon 86				
87 Fr Francium	226 Ra Radium 88	227 Ac Actinium 89 †																			

*58-71 Lanthanoid series

†90-103 Actinoid series

a	a = relative atomic mass
X	X = atomic symbol
b	b = proton (atomic) number

140 Ce Cerium 58	141 Pr Praseodymium 59	144 Nd Neodymium 60	147 Pm Promethium 61	150 Sm Samarium 62	152 Eu Europium 63	157 Gd Gadolinium 64	159 Tb Terbium 65	162 Dy Dysprosium 66	165 Ho Holmium 67	167 Er Erbium 68	169 Tm Thulium 69	173 Yb Ytterbium 70	175 Lu Lutetium 71
232 Th Thorium 90	232 Pa Protactinium 91	238 U Uranium 92	238 Np Neptunium 93	244 Pu Plutonium 94	247 Am Americium 95	251 Cm Curium 96	257 Bk Berkelium 97	261 Cf Californium 98	265 Es Einsteinium 99	267 Fm Fermium 100	268 Md Mendelevium 101	270 No Nobelium 102	277 Lr Lawrencium 103

The volume of one mole of any gas is 24 dm³ at room temperature and pressure (r.t.p.).

Permission to reproduce items where third-party owned material protected by copyright is included has been sought and cleared where possible. Every reasonable effort has been made by the publisher (UCLES) to trace copyright holders, but if any items requiring clearance have unwittingly been included the publisher will be pleased to make amends at the earliest possible opportunity.

University of Cambridge International Examinations is part of the Cambridge Assessment Group. Cambridge Assessment is the brand name of University of Cambridge Local Examinations Syndicate (UCLES), which is itself a department of the University of Cambridge.