



UNIVERSITY OF CAMBRIDGE INTERNATIONAL EXAMINATIONS
International General Certificate of Secondary Education

CANDIDATE
NAME

CENTRE
NUMBER

--	--	--	--	--

CANDIDATE
NUMBER

--	--	--	--



CHEMISTRY

0620/32

Paper 3 (Extended)

October/November 2010

1 hour 15 minutes

Candidates answer on the Question Paper.

No Additional Materials are required.

READ THESE INSTRUCTIONS FIRST

Write your Centre number, candidate number and name on all the work you hand in.

Write in dark blue or black pen.

You may use a pencil for any diagrams, graphs or rough working.

Do not use staples, paper clips, highlighters, glue or correction fluid.

DO NOT WRITE IN ANY BARCODES.

Answer **all** questions.

A copy of the Periodic Table is printed on page 16.

At the end of the examination, fasten all your work securely together.

The number of marks is given in brackets [] at the end of each question or part question.

For Examiner's Use

1	
2	
3	
4	
5	
6	
7	
Total	

This document consists of **14** printed pages and **2** blank pages.



1 The following table gives information about six substances.

substance	melting point /°C	boiling point /°C	electrical conductivity as a solid	electrical conductivity as a liquid
A	839	1484	good	good
B	-210	-196	poor	poor
C	776	1497	poor	good
D	-117	78	poor	poor
E	1607	2227	poor	poor
F	-5	102	poor	good

(a) Which substance could have a macromolecular structure, similar to that of silicon(IV) oxide?

..... [1]

(b) Which substances are solids at room temperature?

..... [1]

(c) Which substance could be a metal?

..... [1]

(d) Which substance could be aqueous sodium chloride?

..... [1]

(e) Which substance is an ionic compound?

..... [1]

(f) Which substances are liquids at room temperature?

..... [1]

[Total: 6]

2 An ore of the important metal zinc is zinc blende, ZnS. This is changed into zinc oxide which is reduced to the impure metal by carbon reduction.

(a) (i) How is zinc oxide obtained from zinc sulfide?

.....
..... [2]

(ii) Write a balanced equation for the reduction of zinc oxide by carbon.

..... [1]

(iii) The major impurity in the zinc is cadmium. The boiling point of zinc is 907 °C and that of cadmium is 767 °C.

Name a technique which could be used to separate these two metals.

..... [2]

(b) In common with most metals, zinc is a good conductor of electricity. It is used as an electrode in cells.

(i) Give **two** other uses of zinc.

.....
..... [2]

(ii) Describe the metallic bonding in zinc and then explain why it is a good conductor of electricity.

.....
.....
.....
..... [4]

[Total: 11]

- 3 The decomposition of hydrogen peroxide is catalysed by manganese(IV) oxide.



To 50 cm³ of aqueous hydrogen peroxide, 0.50 g of manganese(IV) oxide was added. The volume of oxygen formed was measured every 20 seconds. The average reaction rate was calculated for each 20 second interval.

time/s	0	20	40	60	80	100
volume of oxygen/cm ³	0	48	70	82	88	88
average reaction rate in cm ³ /s	2.4	1.1	0.3	0.0	0.0

- (a) Explain how the average reaction rate, 2.4 cm³/s, was calculated for the first 20 seconds.

.....
 [2]

- (b) Complete the table. [1]

- (c) Explain why the average reaction rate decreases with time.

.....
 [2]

- (d) The experiment was repeated but 1.0 g of manganese(IV) oxide was added. What effect, if any, would this have on the reaction rate and on the final volume of oxygen? Give a reason for each answer.

effect on rate [1]

reason

..... [2]

effect on final volume of oxygen [1]

reason

..... [2]

[Total: 11]

4 Chromium is a transition element.

(a) (i) Predict **two** differences in the physical properties of chromium and sodium.

.....
..... [2]

(ii) Predict **two** differences in the chemical properties of chromium and sodium.

.....
..... [2]

(b) Chromium is used to electroplate steel objects. The diagram shows how this could be done.

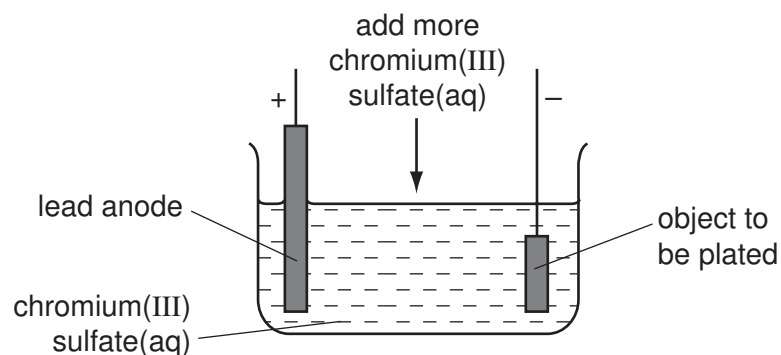

(i) Give **two** reasons why steel objects are plated with chromium.

.....
..... [2]

(ii) The formula of the chromium(III) ion is Cr^{3+} and of the sulfate ion is SO_4^{2-} . Give the formula of chromium(III) sulfate.

..... [1]

(iii) Write the equation for the reaction at the negative electrode (cathode).

..... [2]

(iv) A colourless gas, which relights a glowing splint, is formed at the positive electrode (anode). Name this gas.

..... [1]

- (v) During electrolysis, it is necessary to add more chromium(III) sulfate but during copper-plating using a copper anode, it is not necessary to add more copper(II) sulfate. Explain.

.....
.....
..... [2]

[Total: 12]

- 5 In the absence of oxygen, certain bacteria decompose carbohydrates to biogas. This is a mixture of gases mainly methane and carbon dioxide. Biogas is becoming an increasingly important fuel around the world.

A diagram of a simple biogas generator is given below. Typically, it contains biomass - animal manure, plant material etc.

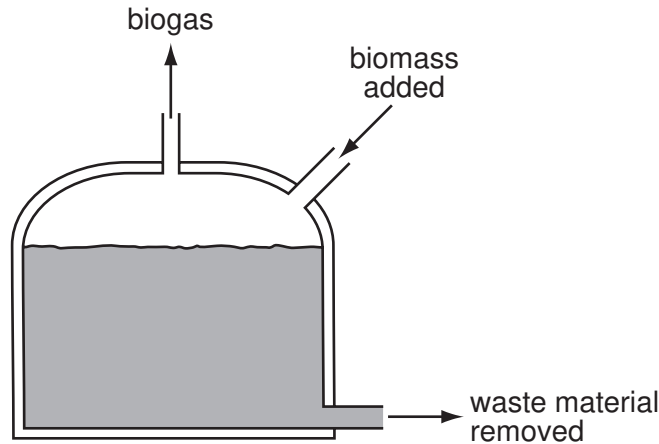

- (a) (i) What is meant by the term *carbohydrate*?

.....
 [2]

- (ii) The reaction in the generator is an example of anaerobic respiration. Anaerobic means in the absence of oxygen. What does *respiration* mean?

.....
 [2]

- (iii) The generator must produce some carbon dioxide. Why is it impossible for it to produce only a hydrocarbon such as methane?

..... [1]

- (iv) Suggest a use for the nitrogen-rich solid removed from the generator.

..... [1]

- (b) (i)** In an experiment, a 60 cm³ sample of biogas required 80 cm³ of oxygen for the complete combustion of the methane in the sample.
Calculate the percentage of methane in the sample of biogas. Assume that biogas contains only methane and carbon dioxide.



.....
.....
..... [2]

- (ii)** Carbon dioxide is acidic and methane is neutral.
Suggest another way of measuring the volume of methane in the sample.

.....
..... [2]

[Total: 10]

6 The alcohols form an homologous series.

(a) Give **three** characteristics of an homologous series.

.....
.....
.....
..... [3]

(b) The following two alcohols are members of the series and they are isomers.

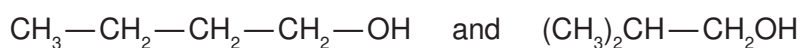

(i) Explain why they are isomers.

.....
.....
..... [2]

(ii) Give the structural formula of another alcohol which is also an isomer of these alcohols.

[1]

(c) Copper(II) oxide can oxidise butan-1-ol to liquid X whose pH is 4.

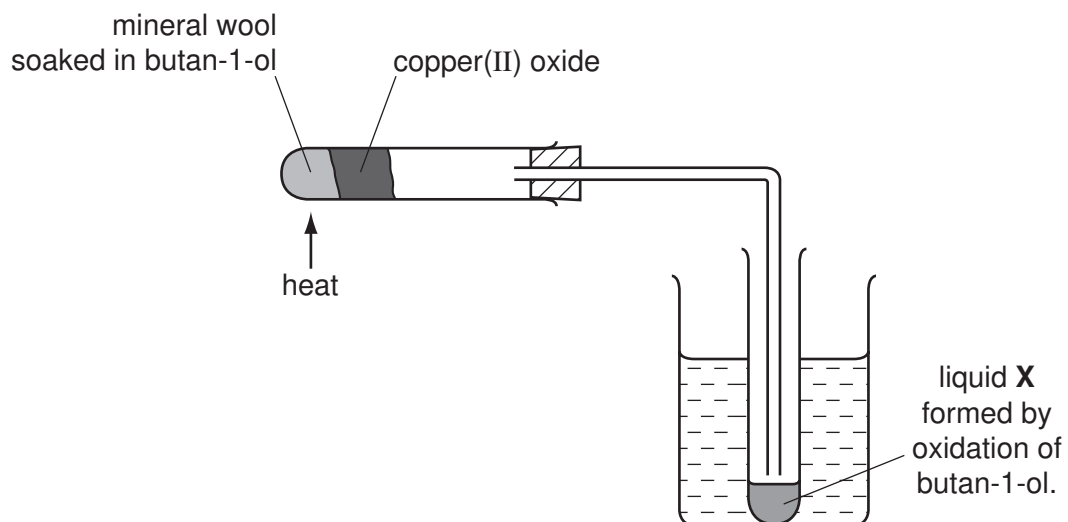

(i) Name another reagent which can oxidise butan-1-ol.

..... [1]

(ii) What type of compound is liquid X and what is its formula?

type of compound [1]

formula of liquid X

[1]

- (d) The alcohol ethanol can be made by fermentation. Yeast is added to aqueous glucose.

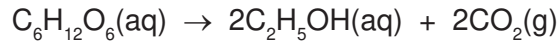

Carbon dioxide is given off and the mixture becomes warm as the reaction is exothermic. The graph shows how the rate of reaction varies over several days.

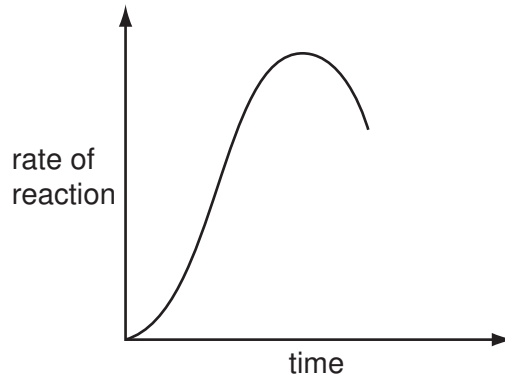

- (i) Suggest a method of measuring the rate of this reaction.

.....
 [2]

- (ii) Why does the rate increase initially?

.....
 [1]

- (iii) Suggest **two** reasons why the rate eventually decreases.

.....
 [2]

- (iv) Why is fermentation carried out in the absence of air?

.....
 [1]

[Total: 15]

7 The major use of sulfur dioxide is to manufacture sulfuric acid.

(a) (i) Another use of sulfur dioxide is as the food additive E220.
How does it preserve food?

.....
..... [1]

(ii) Why is sulfur dioxide used in the manufacture of wood pulp?

..... [1]

(iii) How is sulfur dioxide manufactured?

..... [1]

(b) Complete the following description of the manufacture of sulfuric acid.

Sulfur dioxide reacts with to form sulfur trioxide.

The above reaction is catalysed by

The optimum temperature for this reaction is °C.

Sulfur trioxide needs to react with to form sulfuric acid. [4]

(c) (i) Define the term *acid*.

..... [1]

(ii) Sulfuric acid is a strong acid. Ethanedioic acid is a weak acid.
Given solutions of both acids, how could you show that sulfuric acid is a strong acid
and ethanedioic acid is a weak acid?

method
..... [1]

result for each acid
..... [1]

- (d) 20.0 cm³ of sulfuric acid, concentration 0.30 mol / dm³, was added to 40 cm³ of sodium hydroxide, concentration 0.20 mol / dm³.

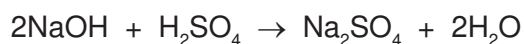

- (i) How many moles of H₂SO₄ were added? [1]
- (ii) How many moles of NaOH were used? [1]
- (iii) Which reagent is in excess? Give a reason for your choice.
- reagent in excess [1]
- reason [1]
- [1]
- (iv) Is the pH of the final mixture less than 7, equal to 7 or more than 7?
- [1]

[Total: 15]

DATA SHEET The Periodic Table of the Elements

Group																							
I	II												III	IV	V	VI	VII	0					
											1 H Hydrogen 1												4 He Helium 2
7 Li Lithium 3	9 Be Beryllium 4												11 B Boron 5	12 C Carbon 6	14 N Nitrogen 7	16 O Oxygen 8	19 F Fluorine 9	20 Ne Neon 10					
23 Na Sodium 11	24 Mg Magnesium 12												27 Al Aluminium 13	28 Si Silicon 14	31 P Phosphorus 15	32 S Sulfur 16	35.5 Cl Chlorine 17	40 Ar Argon 18					
39 K Potassium 19	40 Ca Calcium 20	45 Sc Scandium 21	48 Ti Titanium 22	51 V Vanadium 23	52 Cr Chromium 24	55 Mn Manganese 25	56 Fe Iron 26	59 Co Cobalt 27	59 Ni Nickel 28	64 Cu Copper 29	65 Zn Zinc 30	70 Ga Gallium 31	73 Ge Germanium 32	75 As Arsenic 33	79 Se Selenium 34	80 Br Bromine 35	84 Kr Krypton 36						
85 Rb Rubidium 37	88 Sr Strontium 38	89 Y Yttrium 39	91 Zr Zirconium 40	93 Nb Niobium 41	96 Mo Molybdenum 42	96 Tc Technetium 43	101 Ru Ruthenium 44	103 Rh Rhodium 45	106 Pd Palladium 46	108 Ag Silver 47	112 Cd Cadmium 48	115 In Indium 49	119 Sn Tin 50	122 Sb Antimony 51	128 Te Tellurium 52	127 I Iodine 53	131 Xe Xenon 54						
133 Cs Caesium 55	137 Ba Barium 56	139 La Lanthanum 57 *	178 Hf Hafnium 72	181 Ta Tantalum 73	184 W Tungsten 74	186 Re Rhenium 75	190 Os Osmium 76	192 Ir Iridium 77	195 Pt Platinum 78	197 Au Gold 79	201 Hg Mercury 80	204 Tl Thallium 81	207 Pb Lead 82	209 Bi Bismuth 83	210 Po Polonium 84	210 At Astatine 85	210 Rn Radon 86						
87 Fr Francium	226 Ra Radium 88	227 Ac Actinium 89 †																					

*58-71 Lanthanoid series

†90-103 Actinoid series

a	a = relative atomic mass
X	X = atomic symbol
b	b = proton (atomic) number

140 Ce Cerium 58	141 Pr Praseodymium 59	144 Nd Neodymium 60	147 Pm Promethium 61	150 Sm Samarium 62	152 Eu Europium 63	157 Gd Gadolinium 64	159 Tb Terbium 65	162 Dy Dysprosium 66	165 Ho Holmium 67	167 Er Erbium 68	169 Tm Thulium 69	173 Yb Ytterbium 70	175 Lu Lutetium 71
232 Th Thorium 90	232 Pa Protactinium 91	238 U Uranium 92	238 Np Neptunium 93	244 Pu Plutonium 94	247 Am Americium 95	251 Cm Curium 96	257 Bk Berkelium 97	261 Cf Californium 98	265 Es Einsteinium 99	267 Fm Fermium 100	268 Md Mendelevium 101	269 No Nobelium 102	277 Lr Lawrencium 103

The volume of one mole of any gas is 24 dm³ at room temperature and pressure (r.t.p.).

Permission to reproduce items where third-party owned material protected by copyright is included has been sought and cleared where possible. Every reasonable effort has been made by the publisher (UCLES) to trace copyright holders, but if any items requiring clearance have unwittingly been included the publisher will be pleased to make amends at the earliest possible opportunity.

University of Cambridge International Examinations is part of the Cambridge Assessment Group. Cambridge Assessment is the brand name of University of Cambridge Local Examinations Syndicate (UCLES), which is itself a department of the University of Cambridge.