

UNIVERSITY OF CAMBRIDGE INTERNATIONAL EXAMINATIONS  
International General Certificate of Secondary Education

**BIOLOGY**



Paper 6 Alternative to Practical

**0610/06**

October/November 2006

Candidates answer on the Question Paper.  
No Additional Materials are required

**1 hour**

Candidate  
Name

Centre  
Number

--	--	--	--	--

Candidate  
Number

--	--	--	--

**READ THESE INSTRUCTIONS FIRST**

Write your Centre number, candidate number and name on **all** the work you hand in.

Write in dark blue or black pen.

You may use a pencil for any diagrams or graphs.

Do **not** use staples, paper clips, highlighters, glue or correction fluid.

DO **NOT** WRITE IN THE BARCODE.

DO **NOT** WRITE IN THE GREY AREAS BETWEEN THE PAGES.

Answer **all** questions.

At the end of the examination, fasten all your work securely together.

The number of marks is given in brackets [ ] at the end of each question or part question.

For Examiner's Use	
1	
2	
3	
<b>Total</b>	

This document consists of **8** printed pages and **4** blank pages.

- 1 Fig. 1.1 shows a young plant with its roots submerged in a container filled with a solution containing mineral salts and a coloured dye.

For  
Examiner's  
Use

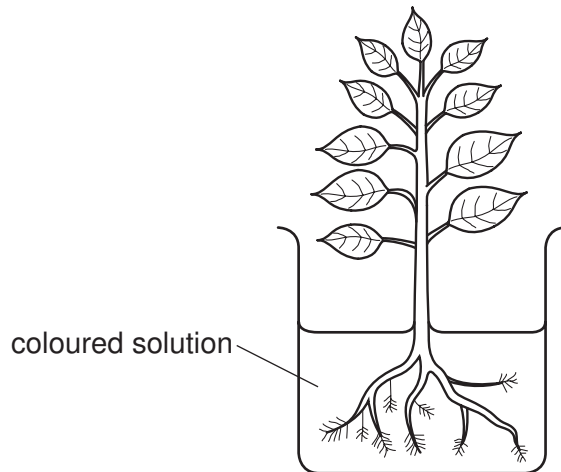

(not to scale)

**Fig. 1.1**

Fig. 1.2 shows a section of a root and Fig. 1.3 shows a section of a stem.

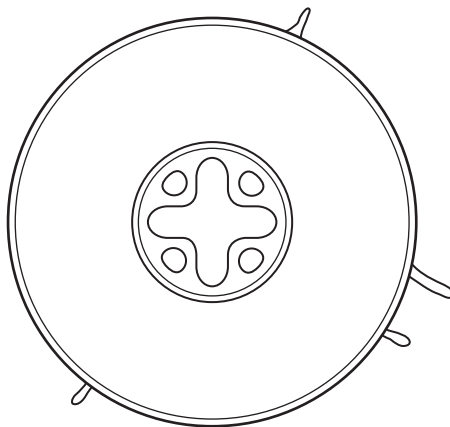

root

**Fig. 1.2**

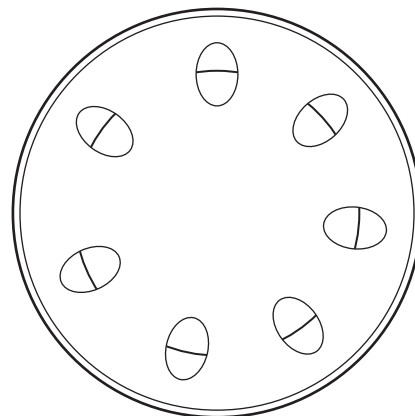

stem

**Fig. 1.3**

- (a) (i) Shade in the tissue to identify where the coloured solution may be found in the section of the root, Fig. 1.2 and stem, Fig. 1.3.

[2]

- (ii) Name the tissue, in both Fig. 1.2 and Fig. 1.3, that you have shaded.

.....

[1]

(b) (i) Name the structures through which most of the solution will be absorbed into the roots.

..... [1]

(ii) Indicate by means of an arrow on Fig. 1.1, **one** place where these structures are shown. [1]

(c) Describe how you would compare the rate of uptake of the coloured solution by the plant in Fig. 1.1 with another plant that has had its roots cut off.

.....  
.....  
.....  
.....  
.....  
.....  
.....  
.....  
.....  
..... [6]

[Total: 11]

2 Fig. 2.1 shows the upper surface of an animal.

For  
Examiner's  
Use



Fig. 2.1

(a) Make a large drawing of the body of this animal and the leg labelled **X**.

Label **one** of the eyes and **two** features of the back leg.

[6]

Figs. 2.2, 2.3 and 2.4, show other examples of the same group (phylum). Each belongs to a different sub-group (class).

For  
Examiner's  
Use

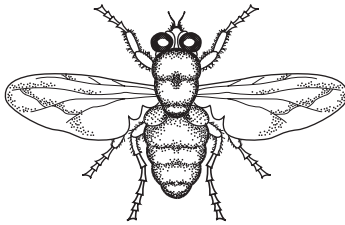

Fig. 2.2

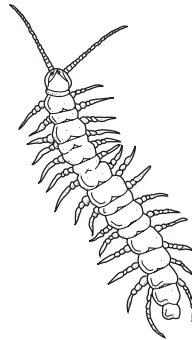

Fig. 2.3

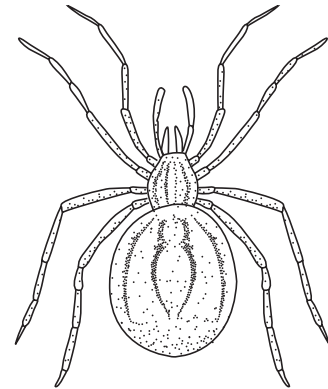

Fig. 2.4

[these animals are not all drawn to the same scale]

(b) (i) Name the main group (phylum) to which these animals belong.

..... [1]

(ii) Describe **one** feature that is characteristic of **all** these animals.

..... [1]

(iii) Complete the table to indicate **one** special feature which makes each sub-group (class) different from all the others.

Fig. 2.2	Fig. 2.3	Fig. 2.4

[3]

(iv) Name each sub-group (class).

Fig. 2.2 .....

Fig. 2.3 .....

Fig. 2.4 ..... [3]

[Total: 14]

- 3 Fig. 3.1 was set up with a number of respiring maggots placed in the large test tube. The apparatus was left for 20 minutes and then a drop of coloured liquid was introduced into the capillary tube as shown.

For  
Examiner's  
Use

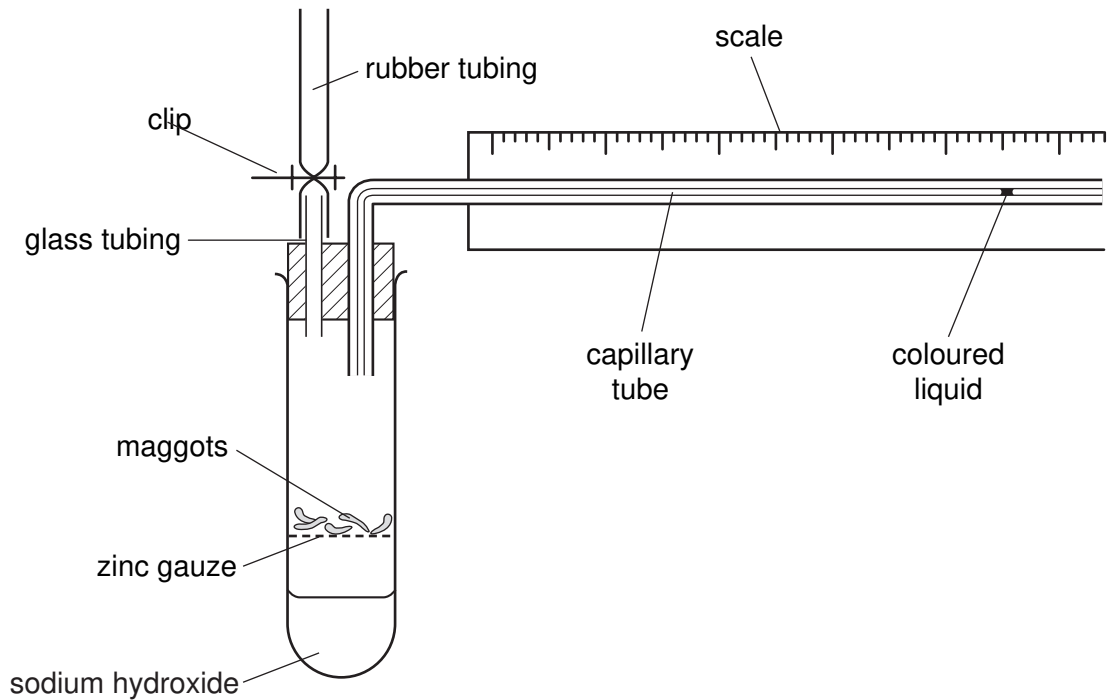

Fig. 3.1

During the next 5 minutes, the drop of coloured liquid moved along the capillary tube. The sodium hydroxide absorbs carbon dioxide.

- (a) (i) Explain why the drop of coloured liquid moved towards the test tube.

.....  
 .....  
 .....  
 .....  
 ..... [3]

- (ii) Describe a suitable control for this investigation.

.....  
 .....  
 ..... [2]

**BLANK PAGE**

**Question 3 continues on page 8**

A second sample of maggots was used in an experiment to show the effect of different temperatures on respiration. The distance that the drop of coloured liquid moved along the capillary tube was measured over a period of 60 seconds at each temperature. The drop of coloured liquid was moved back to the start of the capillary tube before each reading was taken. The results are shown in Table 3.1.

*For  
Examiner's  
Use*

**Table 3.1**

temperature /°C	distance moved by drop of coloured liquid / mm
20	41
25	63
30	96
35	168
40	120

**(b) (i)** Using the results given, plot a graph to show the effect of temperature on respiration.

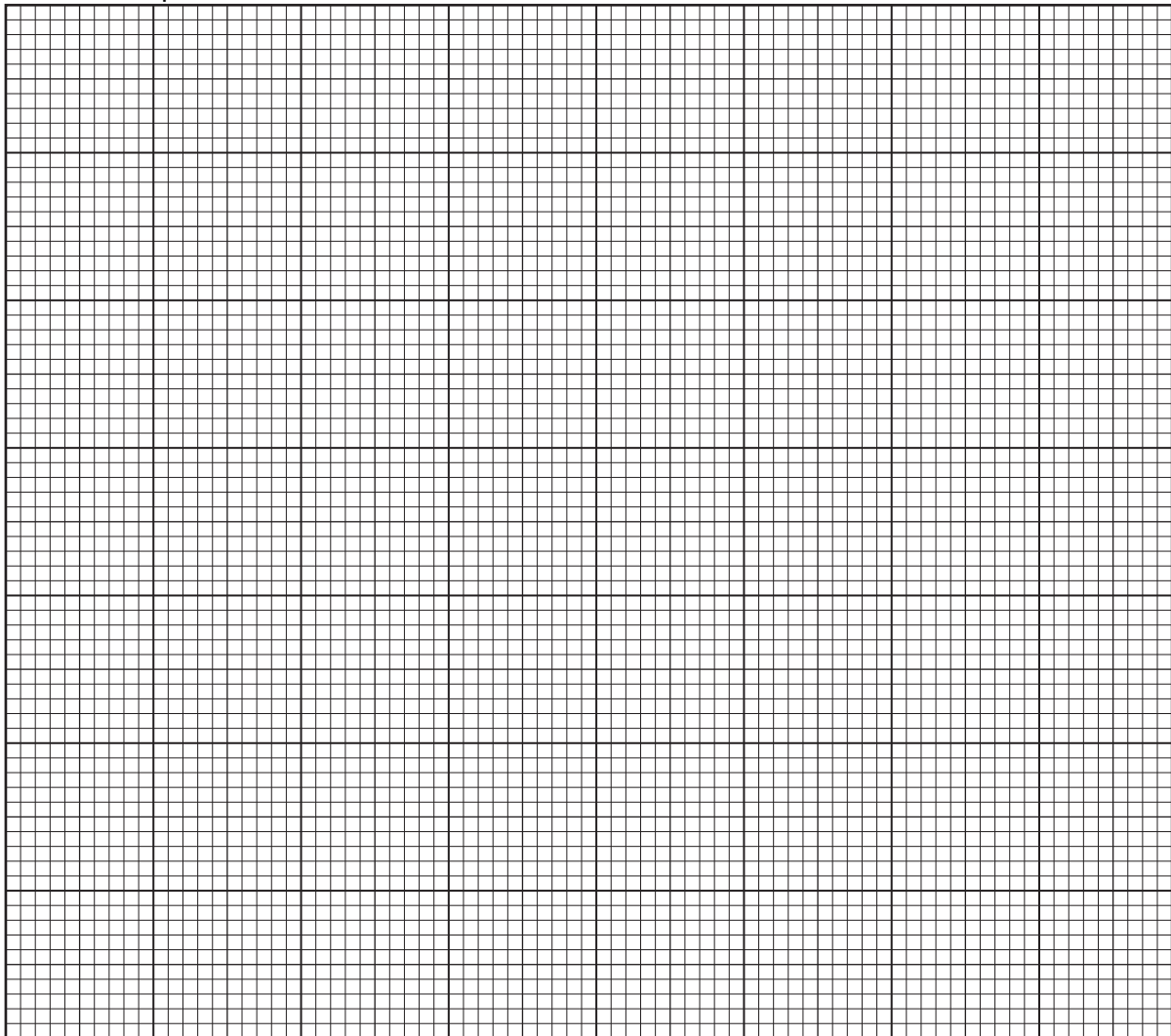

[5]



(ii) With reference to your graph, describe the effect of temperature on the respiration of the maggots.

.....  
.....  
.....  
..... [3]

(iii) Explain the results at 35°C.

.....  
.....  
.....  
..... [2]

[Total: 15]

*For  
Examiner's  
Use*





---

*Copyright Acknowledgements:*

Question 2      Fig. 2.1 © <http://perso.wanadoo.fr/laurent.marzec/pisidia.htm>

Permission to reproduce items where third-party owned material protected by copyright is included has been sought and cleared where possible. Every reasonable effort has been made by the publisher (UCLES) to trace copyright holders, but if any items requiring clearance have unwittingly been included, the publisher will be pleased to make amends at the earliest possible opportunity.

University of Cambridge International Examinations is part of the University of Cambridge Local Examinations Syndicate (UCLES), which is itself a department of the University of Cambridge.