



UNIVERSITY OF CAMBRIDGE INTERNATIONAL EXAMINATIONS
International General Certificate of Secondary Education

www.XtremePapers.com

BIOLOGY

0610/01

Paper 1 Multiple Choice

May/June 2008

45 minutes

Additional Materials: Multiple Choice Answer Sheet
Soft clean eraser
Soft pencil (type B or HB is recommended)

* 6 3 7 2 3 5 7 0 4 1 *

READ THESE INSTRUCTIONS FIRST

Write in soft pencil.

Do not use staples, paper clips, highlighters, glue or correction fluid.

Write your name, Centre number and candidate number on the Answer Sheet in the spaces provided unless this has been done for you.

There are **forty** questions on this paper. Answer **all** questions. For each question there are four possible answers **A, B, C** and **D**.

Choose the **one** you consider correct and record your choice in **soft pencil** on the separate Answer Sheet.

Read the instructions on the Answer Sheet very carefully.

Each correct answer will score one mark. A mark will not be deducted for a wrong answer.
Any rough working should be done in this booklet.

This document consists of **18** printed pages and **2** blank pages.



- 1 The diagram shows some organisms living in water.

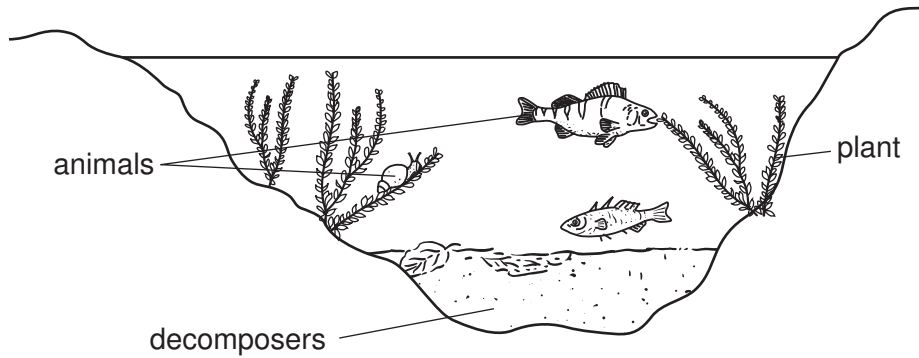

Which process is carried out by all the living organisms shown?

- A photosynthesis
 B pollination
 C respiration
 D transpiration
- 2 The table lists some of the features of three groups of invertebrates – arthropods, annelids and molluscs.

Which shows the correct features of each group?

	arthropods	annelids	molluscs
A	segmented body, exoskeleton and jointed limbs	segmented soft body, rarely have legs	unsegmented soft body, have internal or external shell
B	segmented body, exoskeleton and jointed limbs	segmented body, exoskeleton and jointed limbs	segmented soft body, rarely have legs
C	unsegmented soft body, have internal or external shell	segmented soft body, rarely have legs	unsegmented soft body, have internal or external shell
D	segmented soft body, rarely have legs	unsegmented soft body, have internal or external shell	segmented body, exoskeleton and jointed limbs

- 3 What is the correct order of arthropod groups, from those with most legs to those with fewest legs?
- A arachnids → crustaceans → insects → myriapods
 B crustaceans → myriapods → insects → arachnids
 C insects → arachnids → myriapods → crustaceans
 D myriapods → crustaceans → arachnids → insects

4 The diagram shows an animal.



Use the key to identify this animal.

- 1 rounded ears **A**
 pointed ears go to 2
- 2 spots on the body **B**
 no spots on the body go to 3
- 3 straight tail **C**
 curly tail **D**

5 The diagram shows a type of plant cell.

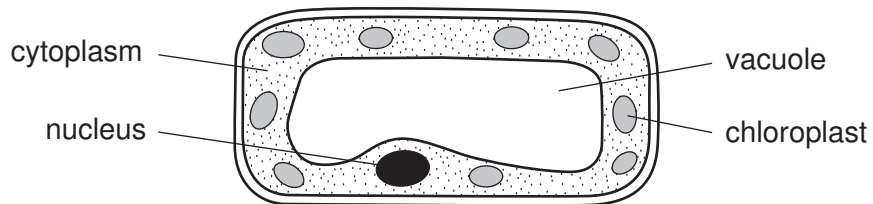

In which tissue is this cell found?

- A** leaf epidermis
B palisade mesophyll
C root epidermis
D xylem
- 6 Which structure is found **only** in plant cells?
- A** cell membrane
B chloroplast
C cytoplasm
D nucleus

7 The table shows features that may be found in cells.

Which is true for a liver cell?

	large central vacuole	chloroplasts	cellulose cell wall
A	✓	✓	✓
B	✓	✓	x
C	x	x	✓
D	x	x	x

key

✓ = found

x = not found

8 What do all living things release during respiration?

	energy	oxygen	carbon dioxide
A	✓	x	✓
B	✓	x	x
C	x	✓	✓
D	x	✓	x

key

✓ = released

x = not released

9 The diagram shows a section through an eye.

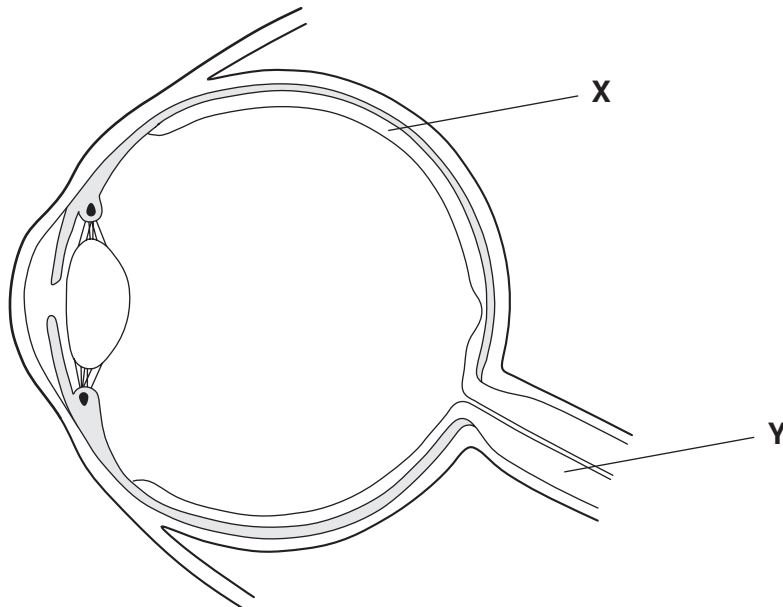

What are structures **X** and **Y**?

- A** organs in an organ system
- B** organs in a tissue
- C** organ systems in an organ
- D** tissues in an organ

10 A student investigated osmosis in potatoes. He set up the apparatus shown.

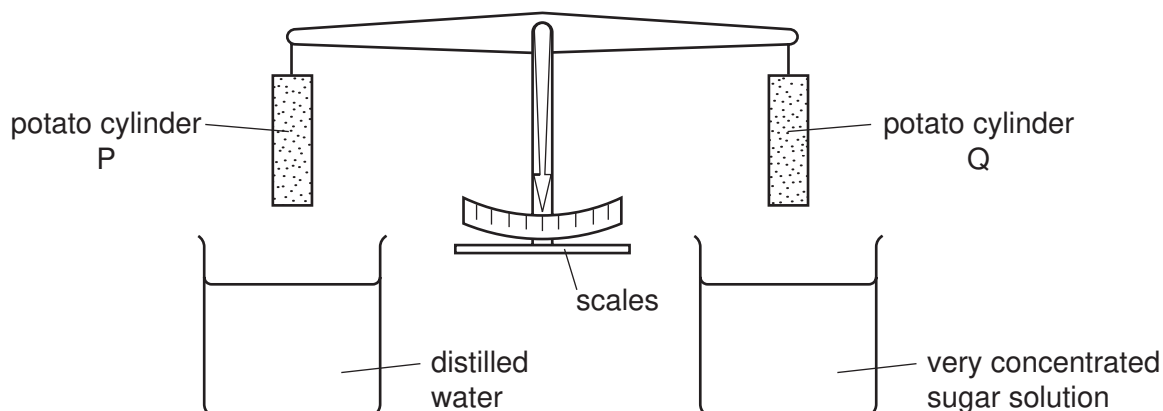

At the beginning the potato cylinders were exactly balanced. He immersed the cylinders into the liquids for 4 hours, after which the cylinders were lifted out of the liquids. Cylinder P was now heavier than cylinder Q.

Which statement explains what happened?

- A Water moved into both cylinders.
- B Water moved out of both cylinders.
- C Water moved into the cylinder in the distilled water and out of the cylinder in the sugar solution.
- D Water moved out of the cylinder in the distilled water and into the cylinder in the sugar solution.

11 An experiment is set up as shown.

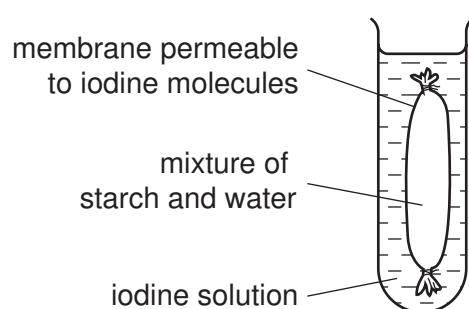

What is the colour of the starch and water mixture after 30 minutes?

- A blue-black
- B orange
- C white
- D yellow-brown

12 Which are characteristics of enzymes?

- A They are carbohydrates and biological catalysts.
- B They are carbohydrates and chemical messengers.
- C They are proteins and biological catalysts.
- D They are proteins and chemical messengers.

13 The diagram shows part of the digestive system.

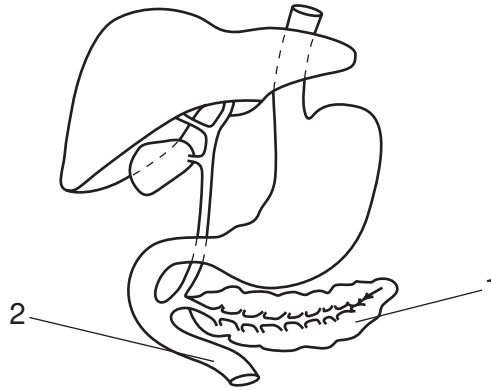

What is a function of the liquid produced by part 1 and released into part 2?

- A to digest proteins to amino acids
- B to increase the surface area of fat droplets
- C to acidify the contents of part 2
- D to prevent further digestion of starch

14 The graphs show the quantities of selected vitamins and minerals in four foods.

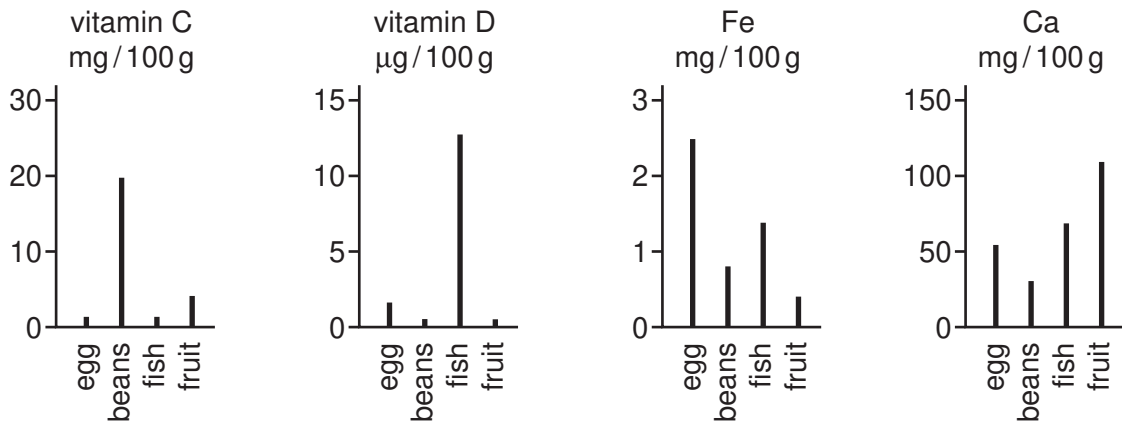

Which food is the richest source of the vitamin or mineral essential for the transport of oxygen by the blood?

- A beans
- B eggs
- C fish
- D fruit

15 The table shows whether starch was still present after four different experiments.

experiment	result
starch + water at 20 °C	✓
starch + amylase at 20 °C	✗
starch + amylase at 30 °C	✗
starch + boiled amylase at 30 °C	✓

key
 ✓ = starch present
 ✗ = starch absent

What broke down the starch?

- A amylase
- B boiled amylase
- C heat
- D water

16 The diagram shows blood as seen under a microscope.

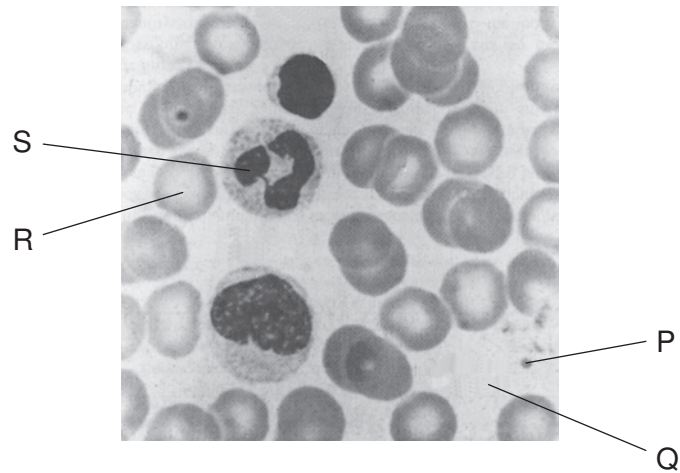

Which identifies parts P, Q, R and S of the blood?

	plasma	platelet	white blood cell	red blood cell
A	P	Q	R	S
B	Q	P	S	R
C	R	S	Q	P
D	S	R	P	Q

17 In which state does water enter and leave a plant?

	enters	leaves
A	liquid	liquid
B	liquid	vapour
C	vapour	liquid
D	vapour	vapour

18 The plan shows the blood system of a mammal.

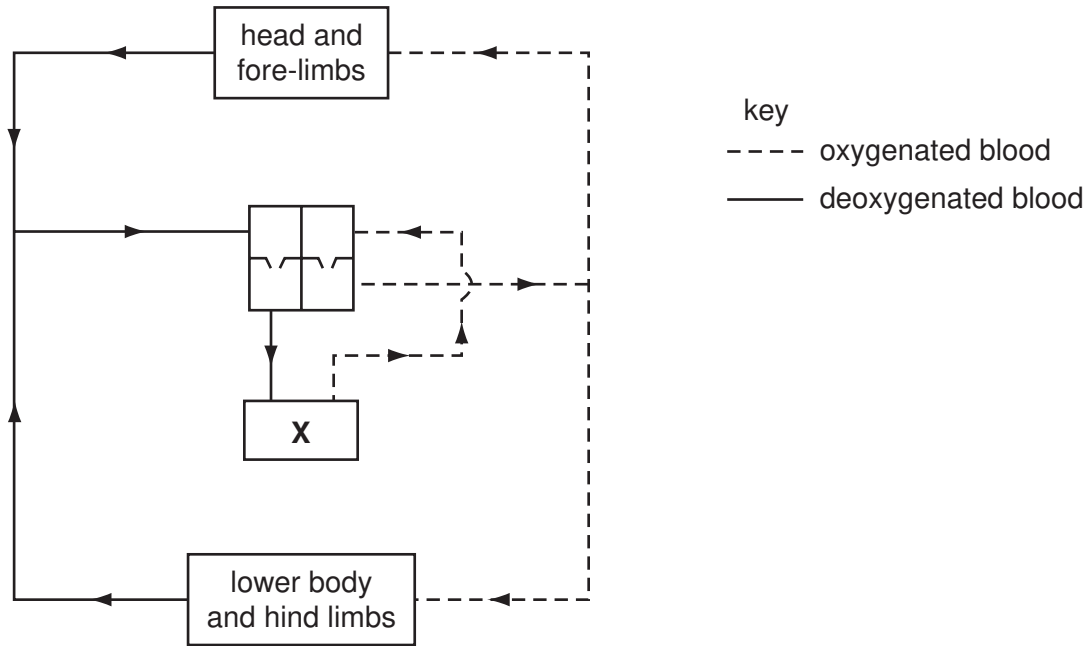

What does the part labelled **X** represent?

- A heart
- B kidneys
- C liver
- D lungs

19 Which route is taken by air passing into the lungs of a human?

- A alveolus → trachea → bronchus
- B bronchus → trachea → alveolus
- C trachea → alveolus → bronchus
- D trachea → bronchus → alveolus

20 Which products of anaerobic respiration are important for making beer and bread?

	beer	bread
A	carbon dioxide	simple sugar
B	ethanol	carbon dioxide
C	lactic acid	ethanol
D	simple sugar	lactic acid

21 A person has been smoking heavily for many years.

A lot of dust and micro-organisms enter their lungs.

Which statement explains why this occurs?

- A Their arteries are blocked with tar.
- B The cilia in the trachea have been destroyed.
- C The person is addicted to nicotine.
- D The surface area of the lungs is reduced.

22 Capillaries near the surface of the skin become wider after drinking large amounts of alcohol.

Why does this cause the body temperature to drop?

- A It allows heat to be lost rapidly from the skin.
- B It causes vasoconstriction.
- C It prevents vasodilation.
- D It stops the person from sweating.

23 The diagram represents some human organs and their blood vessels.

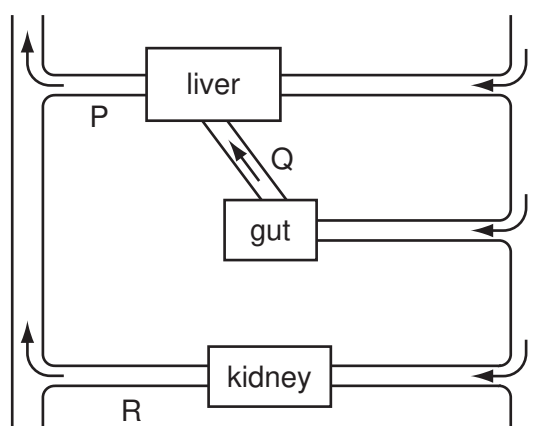

Immediately after taking an alcoholic drink, how would the levels of alcohol compare in blood vessels P, Q and R?

	P	Q	R
A	very high	some	very high
B	some	very high	very low
C	very low	very low	some
D	very high	very low	very low

24 The diagram shows muscles and bones in a human arm.

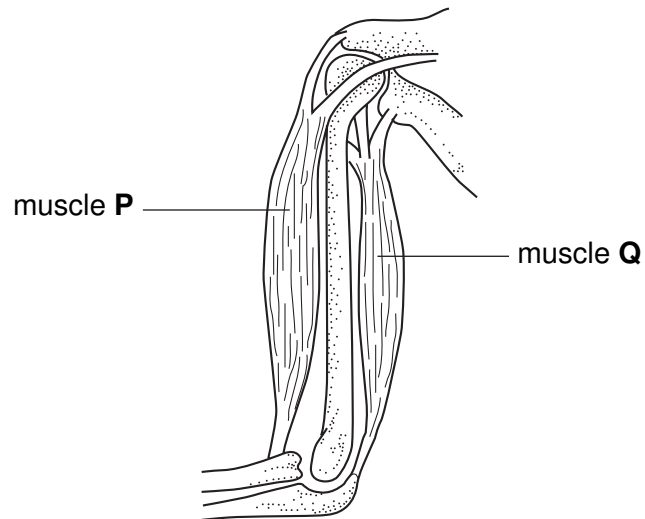

When muscle **Q** contracts, what happens to muscle **P** and to the arm?

	muscle P	the arm
A	contracts	bends
B	contracts	straightens
C	relaxes	bends
D	relaxes	straightens

- 25 Thirty woodlice were placed in the centre of a dish with four compartments, each with different conditions. The diagram shows the number of woodlice that had moved into the different compartments after twenty minutes.

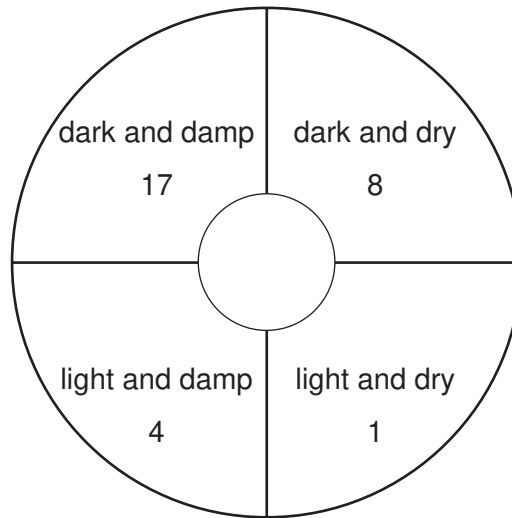

What do these results show?

- A Woodlice prefer light and damp conditions.
 - B Woodlice prefer light and dry conditions.
 - C Woodlice prefer to be in the dark.
 - D Woodlice prefer to be in the light.
- 26 Which shows where eggs and sperms are made?

	eggs	sperms
A	fallopian tube (oviduct)	sperm duct
B	ovary	testis
C	ovary	urethra
D	uterus	testis

27 The following four processes occur during reproduction in a plant.

- 1 The male nucleus fuses with the female nucleus.
- 2 The male nucleus is released from the pollen tube.
- 3 The male nucleus travels down the pollen tube.
- 4 The pollen grain grows a pollen tube.

In which order do these processes occur after pollination?

	first	→	last
A	3	4	1 2
B	4	3	2 1
C	3	4	2 1
D	4	3	1 2

28 Which set of conditions will best enable seeds to germinate quickly?

	water	oxygen	temperature (°C)
A	absent	present	20
B	present	absent	20
C	present	present	20
D	present	present	0

29 In arthropods, growth occurs only after the exoskeleton is shed and before the new one hardens.

Which graph shows a typical growth curve for an arthropod?

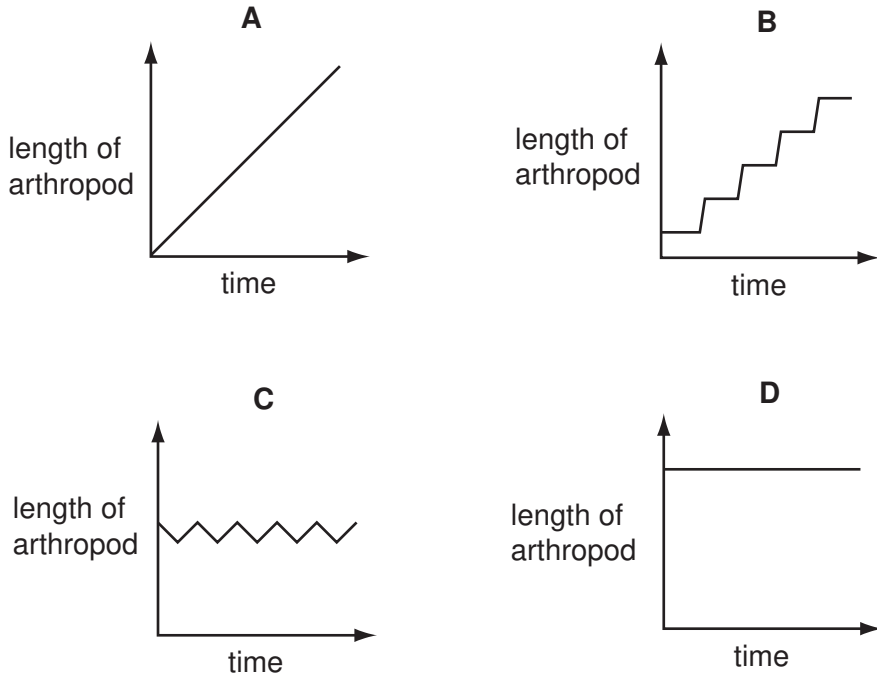

30 In the life cycle of a mammal, what describes the eggs or sperms and the cells of the embryo?

	eggs or sperms	cells of the embryo
A	diploid	diploid
B	diploid	haploid
C	haploid	diploid
D	haploid	haploid

31 Which cross shows how a boy inherits sex chromosomes from his parents?

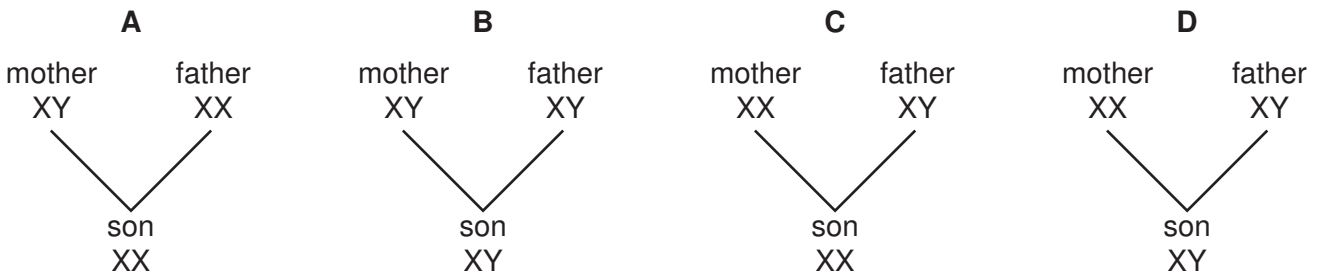

32 The diagram shows a food chain.

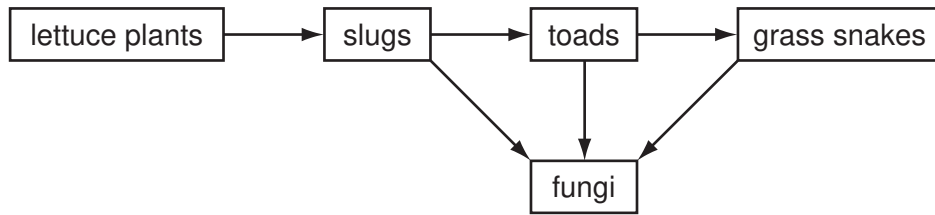

Which organisms are the producers?

- A grass snakes
- B lettuce plants
- C slugs
- D toads

33 The diagram shows energy flow through a food chain.

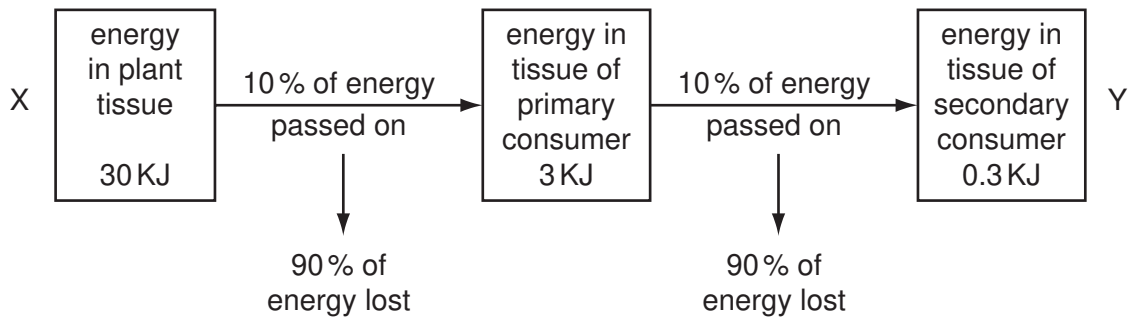

By which processes is energy lost between X and Y?

- A digestion and excretion
- B digestion and photosynthesis
- C excretion and respiration
- D photosynthesis and respiration

34 The diagram shows a simple water cycle.

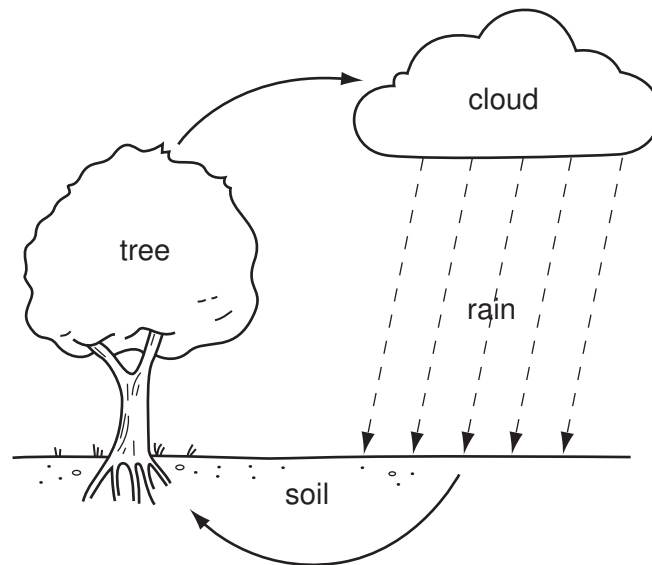

What is responsible for water loss from the tree?

- A decomposition
- B photosynthesis
- C translocation
- D transpiration

35 Which shows from where most plants and most animals obtain carbon?

	most plants obtain carbon from	most animals obtain carbon from
A	the air	plants
B	the soil	the air
C	the air	the soil
D	the soil	plants

36 What does a plant make with the nitrates it absorbs?

- A carbohydrates
- B fats
- C mineral salts
- D proteins

37 The table shows the changes in the world population over a period of two hundred years.

year	estimated population (millions)
1790	850
1890	1500
1990	5000

What has made the largest contribution to this population change?

- A decreased food supply
 - B decreased use of chemical contraception
 - C increased food supply
 - D increased use of chemical contraception
- 38 Why might pesticides sprayed onto the fields reduce a bean crop?
- A Pesticides damage plant leaves.
 - B Pesticides damage plant roots.
 - C Pesticides kill insects that feed on bean plants.
 - D Pesticides kill insects that pollinate bean plants.
- 39 What may cause the rapid growth of plants in a lake?
- A excess fertilisers
 - B excess herbicides
 - C low water pH
 - D low water temperature

40 The table shows some information about two closely related species of sea bird.

bird species X	bird species Y
mixed diet, but no small fish catches fish out at sea nests high on cliffs or broad ledges	eats mostly small fish catches fish near river mouths nests low on cliffs or on shallow ledges

Sewage pollution at the mouth of a river destroys its fish stocks.

What is likely to happen to local populations of these birds?

- A There will be no change to either species.
- B Species X numbers will decrease, species Y will remain constant.
- C Species Y numbers will decrease, species X will remain constant.
- D Both species numbers will increase.

BLANK PAGE

BLANK PAGE

Permission to reproduce items where third-party owned material protected by copyright is included has been sought and cleared where possible. Every reasonable effort has been made by the publisher (UCLES) to trace copyright holders, but if any items requiring clearance have unwittingly been included, the publisher will be pleased to make amends at the earliest possible opportunity.

University of Cambridge International Examinations is part of the Cambridge Assessment Group. Cambridge Assessment is the brand name of University of Cambridge Local Examinations Syndicate (UCLES), which is itself a department of the University of Cambridge.