

Location Entry Codes

As part of CIE's continual commitment to maintaining best practice in assessment, CIE uses different variants of some question papers for our most popular assessments with large and widespread candidature. The question papers are closely related and the relationships between them have been thoroughly established using our assessment expertise. All versions of the paper give assessment of equal standard.

The content assessed by the examination papers and the type of questions is unchanged.

This change means that for this component there are now two variant Question Papers, Mark Schemes and Principal Examiner's Reports where previously there was only one. For any individual country, it is intended that only one variant is used. This document contains both variants which will give all Centres access to even more past examination material than is usually the case.

The diagram shows the relationship between the Question Papers, Mark Schemes and Principal Examiners' Reports that are available.

Question Paper	Mark Scheme	Principal Examiner's Report
Introduction	Introduction	Introduction
First variant Question Paper	First variant Mark Scheme	First variant Principal Examiner's Report
Second variant Question Paper	Second variant Mark Scheme	Second variant Principal Examiner's Report

Who can I contact for further information on these changes?

Please direct any questions about this to CIE's Customer Services team at:

international@cie.org.uk

The titles for the variant items should correspond with the table above, so that at the top of the first page of the relevant part of the document and on the header, it has the words:

- First variant Question Paper / Mark Scheme / Principal Examiner's Report

or

- Second variant Question Paper / Mark Scheme / Principal Examiner's Report

as appropriate.

First Variant Question Paper



UNIVERSITY OF CAMBRIDGE INTERNATIONAL EXAMINATIONS
International General Certificate of Secondary Education

CANDIDATE
NAME

CENTRE
NUMBER

--	--	--	--	--

CANDIDATE
NUMBER

--	--	--	--



MATHEMATICS

0580/11, 0581/11

Paper 1 (Core)

May/June 2008

1 hour

Candidates answer on the Question Paper.

Additional Materials:

Electronic Calculator
Geometrical Instruments

Mathematical tables (optional)
Tracing paper (optional)

READ THESE INSTRUCTIONS FIRST

Write your Centre number, candidate number and name on all the work you hand in.

Write in dark blue or black pen.

You may use a pencil for any diagrams or graphs.

Do not use staples, paper clips, highlighters, glue or correction fluid.

DO NOT WRITE IN ANY BARCODES.

Answer **all** questions.

If working is needed for any question it must be shown below that question.

Electronic calculators should be used.

If the degree of accuracy is not specified in the question, and if the answer is not exact, give the answer to three significant figures. Give answers in degrees to one decimal place.

For π , use either your calculator value or 3.142.

At the end of the examination, fasten all your work securely together.

The number of marks is given in brackets [] at the end of each question or part question.

The total of the marks for this paper is 56.

For Examiner's Use

--

This document consists of **12** printed pages.



- 1 Work out the value of $\frac{11+4\times 7}{3}$.

Answer [1]

- 2 A train leaves Paris at 10 56 and arrives in Marseille at 13 12.

How long does the journey take?

Give your answer in hours and minutes.

Answer h min [1]

- 3

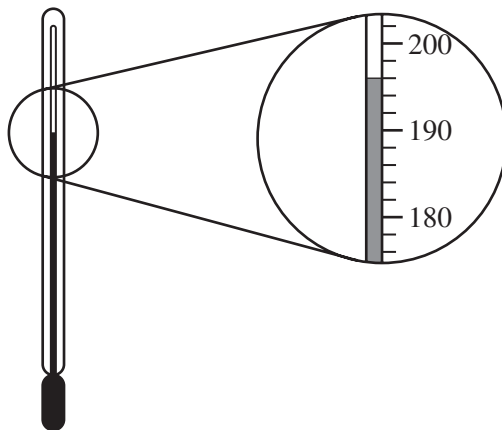

The diagram above shows part of a thermometer which measures the temperature in °C inside an oven.

What is the temperature in the oven?

Answer °C [1]

- 4 When Jon opened a packet containing 30 biscuits, he found that 3 biscuits were broken.

What percentage of the biscuits were broken?

Answer % [1]

- 5 Write the following in order, starting with the smallest.

0.35 33% $\frac{1}{3}$

Answer < < [1]

- 6 In May, the average temperature in Kiev was 12 °C.

In February, the average temperature was 26 °C lower than in May.

What was the average temperature in February?

Answer °C [1]

- 7 Write 0.00362 in standard form.

Answer [1]

For
Examiner's
Use

8

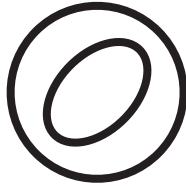

For
Examiner's
Use

For the diagram above, write down

(a) the number of lines of symmetry,

Answer(a) [1]

(b) the order of rotational symmetry.

Answer(b) [1]

- 9 Rehana pays \$284 in tax.
This is $\frac{2}{9}$ of the money she earns.
How much does Rehana earn?

Answer \$ [2]

- 10 The height, h metres, of a telegraph pole is 12 metres correct to the nearest metre.

Complete the statement about the value of h .

Answer $\leq h <$ [2]

- 11 A packet of sweets costs \$2.45.

Felipe and his brother share the cost in the ratio 4 : 3.

How much does Felipe pay?

Answer \$ [2]

- 12 (a) There are 11 boys and 13 girls in a choir.

The teacher chooses one choir member at random.

What is the probability that this is a girl?

Write your answer as a fraction.

Answer(a) [1]

- (b) The probability that Carla arrives at school before 08 00 is $\frac{9}{20}$.

What is the probability that Carla does not arrive before 08 00?

Write your answer as a fraction.

Answer(b) [1]

13

NOT TO
SCALE

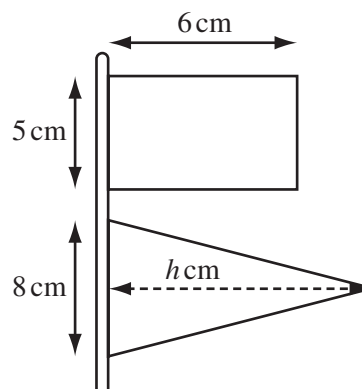

A model ship is flying two flags.

The first is a rectangle 5 centimetres by 6 centimetres.

The second is an isosceles triangle with base 8 centimetres and height h centimetres.

The flags are equal in area.

Find the value of h .

Answer $h =$ [2]

- 14 Find the circumference of a circle of radius 5.7 cm.
Write down your answer

(a) exactly as it appears on your calculator,

Answer(a) cm [1]

(b) correct to the nearest centimetre.

Answer(b) cm [1]

15

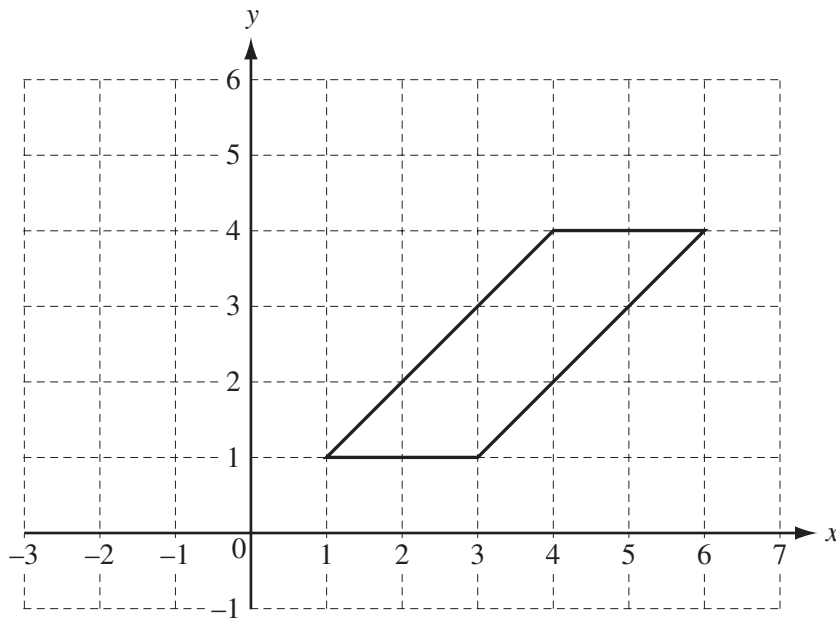

On the grid, draw the reflection of the parallelogram in the line $x = 3$.

[2]

16

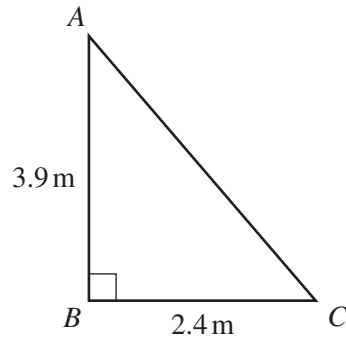
NOT TO
SCALE

ABC is a right-angled triangle.
 $AB = 3.9$ m and $BC = 2.4$ m.
 Calculate the length of AC .

Answer $AC =$ m [2]

- 17 A shop sells batteries at 68 cents each, or \$2.15 for a pack of four.
 How much will Daniel save if he buys two packs of four instead of 8 single batteries?

Answer \$ [2]

- 18 Factorise completely

$$6x - 9x^2y.$$

Answer [2]

19 (a) When $x = -3$ and $y = 4$, find the value of

(i) x^3 ,

Answer(a)(i) [1]

(ii) xy^2 .

Answer(a)(ii) [1]

(b) Simplify $\frac{z^{-1}}{z^{-2}}$.

Answer(b) [1]

20

$\sqrt{4}$ $\sqrt{14}$ $\sqrt{36}$ $\sqrt{64}$ $\sqrt{81}$ $\sqrt{100}$

From the list above, write down

(a) a prime number,

Answer(a) [1]

(b) a factor of 27,

Answer(b) [1]

(c) a multiple of 4,

Answer(c) [1]

(d) an irrational number.

Answer(d) [1]

21

For
Examiner's
Use

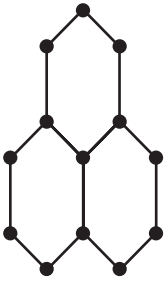

Diagram 1

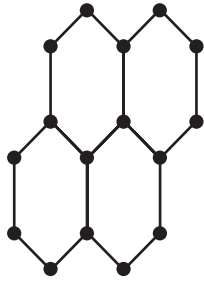

Diagram 2

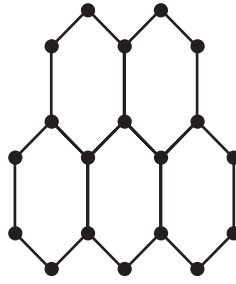

Diagram 3

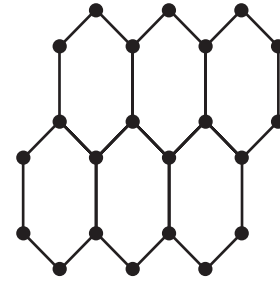

Diagram 4

Look at the sequence of diagrams above.
The number of dots in each diagram is given in the table below.

Diagram number	1	2	3	4	
Number of dots	13	16	19	22	

Find the number of dots in

(a) Diagram 5,

Answer(a) [1]

(b) Diagram 11,

Answer(b) [1]

(c) Diagram n .

Answer(c) [2]

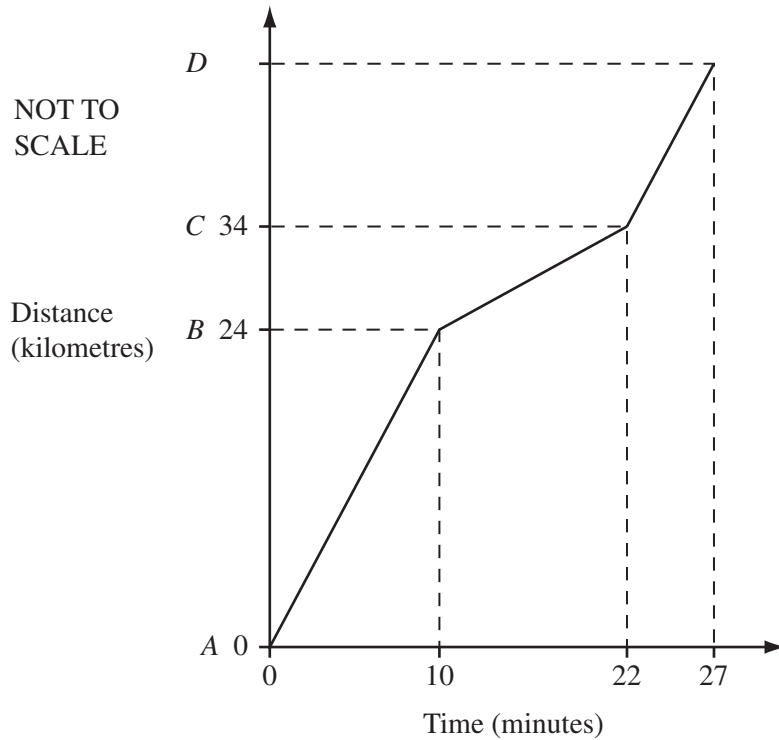

The diagram shows the graph of Rachel's journey on a motorway. Starting at *A*, she drove 24 kilometres to *B* at a constant speed. Between *B* and *C* she had to drive slowly through road works. At *C* she drove a further distance to *D* at her original speed.

(a) For how many minutes was she driving through the road works?

Answer(a) min [1]

(b) At what speed did she drive through the road works?
Give your answer in

(i) kilometres/minute,

Answer(b)(i) km/min [1]

(ii) kilometres/hour.

Answer(b)(ii) km/h [1]

(c) What is the total distance from *A* to *D*?

Answer(c) km [2]

23 Nicolas needs to borrow \$4000 for 3 years. The bank offers him a choice:

*For
Examiner's
Use*

<p>Offer A</p> <p>Interest Rate 8.5% per year</p> <p>Pay the interest at the end of</p> <p>each year</p>
--

<p>Offer B</p> <p>Interest Rate 8% per year</p> <p>Pay all the interest at the end of</p> <p>three years</p>
--

Nicolas recognises that offer A is simple interest and offer B is compound interest.

(a) If he takes offer A, what is the total amount of interest he will pay?

Answer(a) \$ [2]

(b) If he takes offer B, how much **interest** will he pay?
Give your answer correct to 2 decimal places.

Answer(b) \$ [3]

24

$$\mathbf{a} = \begin{pmatrix} 3 \\ -2 \end{pmatrix} \quad \text{and} \quad \mathbf{b} = \begin{pmatrix} -1 \\ 2 \end{pmatrix}$$

For
Examiner's
Use

(a) Work out

(i) $\mathbf{a} + 3\mathbf{b}$,

$$\text{Answer(a)(i)} \quad \begin{pmatrix} \\ \end{pmatrix} \quad [2]$$

(ii) $\mathbf{b} - \mathbf{a}$.

$$\text{Answer(a)(ii)} \quad \begin{pmatrix} \\ \end{pmatrix} \quad [2]$$

(b) $\vec{PQ} = 2\mathbf{b}$.

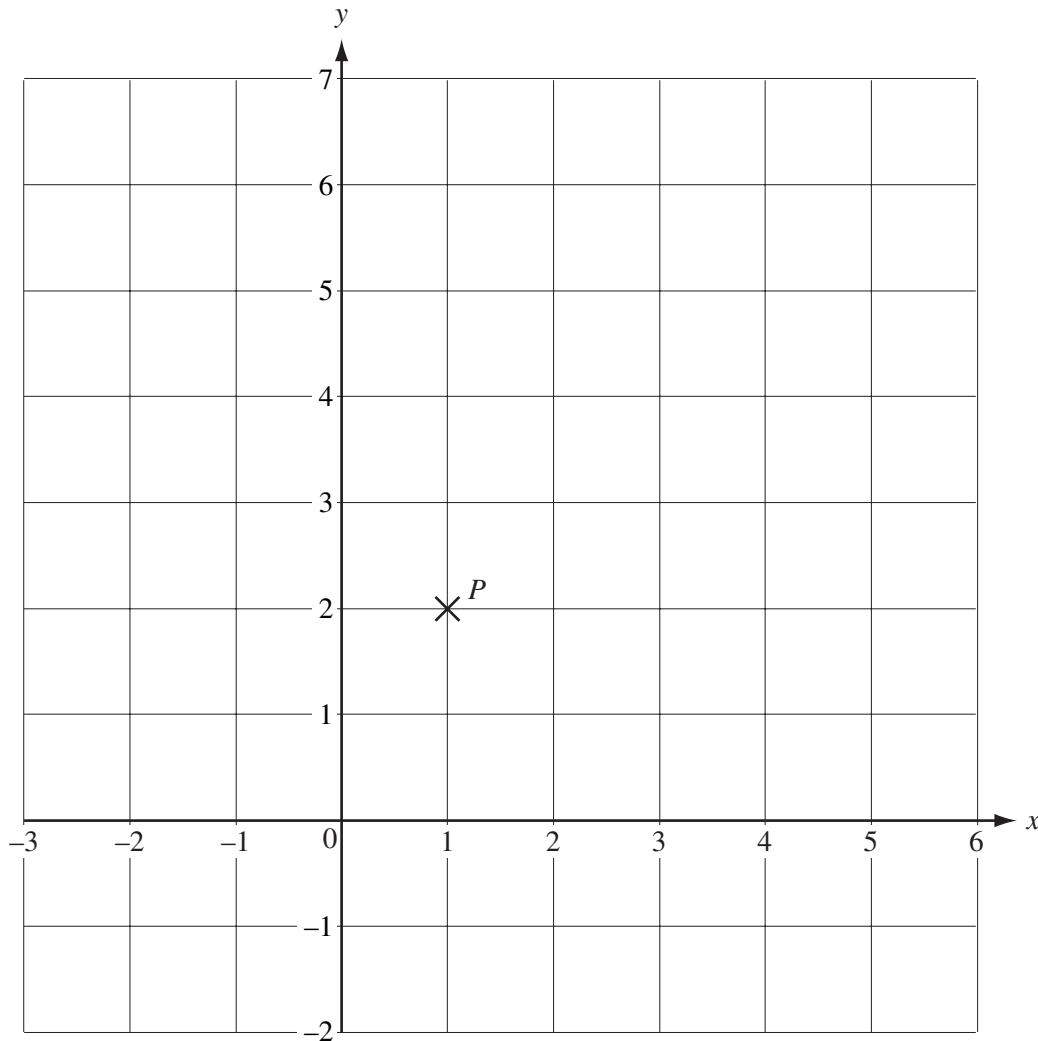
The point P is marked on the grid below.Draw the vector \vec{PQ} on the grid.

[2]

Permission to reproduce items where third-party owned material protected by copyright is included has been sought and cleared where possible. Every reasonable effort has been made by the publisher (UCLES) to trace copyright holders, but if any items requiring clearance have unwittingly been included, the publisher will be pleased to make amends at the earliest possible opportunity.

University of Cambridge International Examinations is part of the Cambridge Assessment Group. Cambridge Assessment is the brand name of University of Cambridge Local Examinations Syndicate (UCLES), which is itself a department of the University of Cambridge.

Second Variant Question Paper



UNIVERSITY OF CAMBRIDGE INTERNATIONAL EXAMINATIONS
International General Certificate of Secondary Education

CANDIDATE
NAME

CENTRE
NUMBER

--	--	--	--	--

CANDIDATE
NUMBER

--	--	--	--

* 9 3 9 4 0 7 1 9 9 2 *

MATHEMATICS

0580/12, 0581/12

Paper 1 (Core)

May/June 2008

1 hour

Candidates answer on the Question Paper.

Additional Materials:

Electronic Calculator
Geometrical Instruments

Mathematical tables (optional)
Tracing paper (optional)

READ THESE INSTRUCTIONS FIRST

Write your Centre number, candidate number and name on all the work you hand in.

Write in dark blue or black pen.

You may use a pencil for any diagrams or graphs.

Do not use staples, paper clips, highlighters, glue or correction fluid.

DO NOT WRITE IN ANY BARCODES.

Answer **all** questions.

If working is needed for any question it must be shown below that question.

Electronic calculators should be used.

If the degree of accuracy is not specified in the question, and if the answer is not exact, give the answer to three significant figures. Give answers in degrees to one decimal place.

For π , use either your calculator value or 3.142.

At the end of the examination, fasten all your work securely together.

The number of marks is given in brackets [] at the end of each question or part question.

The total of the marks for this paper is 56.

This document consists of **12** printed pages.



- 1 Work out the value of $\frac{12 + 3 \times 11}{5}$.

Answer [1]

- 2 A train leaves Paris at 9 52 and arrives in Marseille at 13 21.

How long does the journey take?

Give your answer in hours and minutes.

Answer h min [1]

- 3

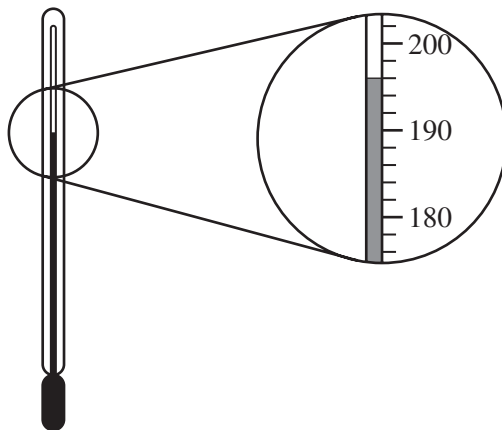

The diagram above shows part of a thermometer which measures the temperature in °C inside an oven.

What is the temperature in the oven?

Answer °C [1]

- 4 When Jon opened a packet containing 40 biscuits, he found that 8 biscuits were broken.

What percentage of the biscuits were broken?

Answer % [1]

- 5 Write the following in order, starting with the smallest.

0.35 33% $\frac{1}{3}$

Answer < < [1]

- 6 In May, the average temperature in Kiev was 13 °C.

In February, the average temperature was 22 °C lower than in May.

What was the average temperature in February?

Answer °C [1]

- 7 Write 0.00362 in standard form.

Answer [1]

*For
Examiner's
Use*

8

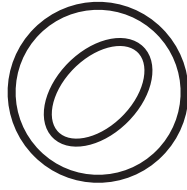

For
Examiner's
Use

For the diagram above, write down

(a) the number of lines of symmetry,

Answer(a) [1]

(b) the order of rotational symmetry.

Answer(b) [1]

- 9 Rehana pays \$276 in tax.
This is $\frac{3}{11}$ of the money she earns.
How much does Rehana earn?

Answer \$ [2]

- 10 The height, h metres, of a telegraph pole is 12 metres correct to the nearest metre.
Complete the statement about the value of h .

Answer $\leq h <$ [2]

- 11 A packet of sweets costs \$2.25.
Felipe and his brother share the cost in the ratio 5 : 4.
How much does Felipe pay?

Answer \$ [2]

- 12 (a) There are 12 boys and 17 girls in a choir.

The teacher chooses one choir member at random.

What is the probability that this is a girl?

Write your answer as a fraction.

Answer(a) [1]

- (b) The probability that Carla arrives at school before 08 00 is $\frac{7}{20}$.

What is the probability that Carla does not arrive before 08 00?

Write your answer as a fraction.

Answer(b) [1]

13

NOT TO
SCALE

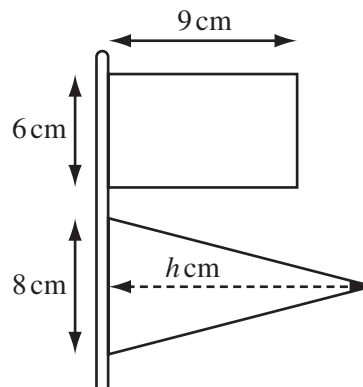

A model ship is flying two flags.

The first is a rectangle 6 centimetres by 9 centimetres.

The second is an isosceles triangle with base 8 centimetres and height h centimetres.

The flags are equal in area.

Find the value of h .

Answer $h =$ [2]

- 14 Find the circumference of a circle of radius 5.2 cm.
Write down your answer

(a) exactly as it appears on your calculator,

Answer(a) cm [1]

(b) correct to the nearest centimetre.

Answer(b) cm [1]

15

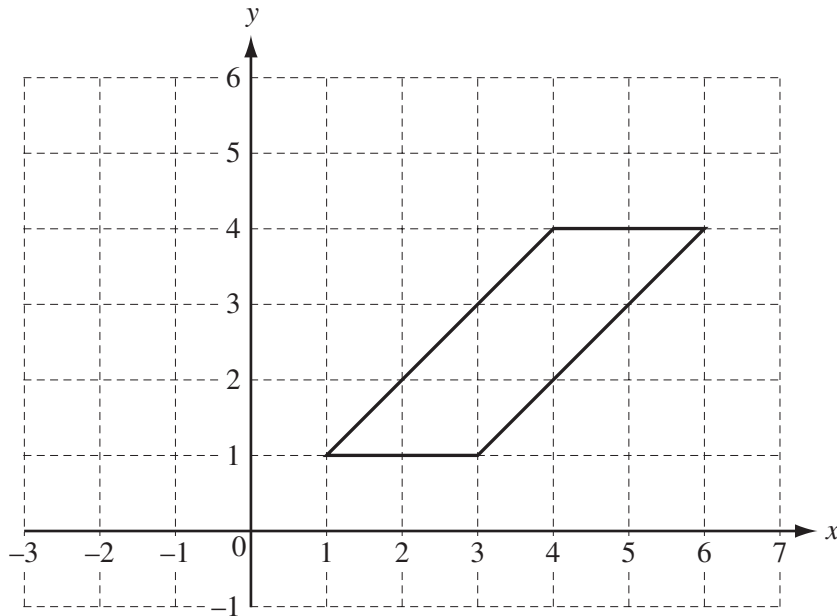

On the grid, draw the reflection of the parallelogram in the line $x = 3$.

[2]

16

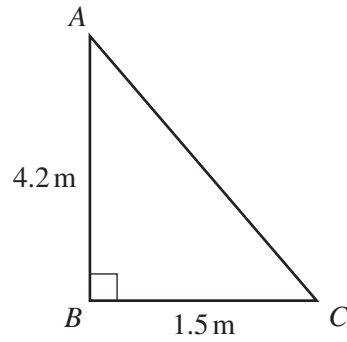
NOT TO
SCALE

ABC is a right-angled triangle.
 $AB = 4.2$ m and $BC = 1.5$ m.
 Calculate the length of AC .

Answer $AC =$ m [2]

- 17 A shop sells batteries at 68 cents each, or \$2.15 for a pack of four.
 How much will Daniel save if he buys two packs of four instead of 8 single batteries?

Answer \$ [2]

- 18 Factorise completely

$$6x - 9x^2y.$$

Answer [2]

19 (a) When $x = -4$ and $y = 6$, find the value of

(i) x^3 ,

Answer(a)(i) [1]

(ii) xy^2 .

Answer(a)(ii) [1]

(b) Simplify $\frac{z^{-1}}{z^{-2}}$.

Answer(b) [1]

20

$\sqrt{4}$ $\sqrt{14}$ $\sqrt{36}$ $\sqrt{64}$ $\sqrt{81}$ $\sqrt{100}$

From the list above, write down

(a) a prime number,

Answer(a) [1]

(b) a factor of 27,

Answer(b) [1]

(c) a multiple of 4,

Answer(c) [1]

(d) an irrational number.

Answer(d) [1]

For
Examiner's
Use

21

For
Examiner's
Use

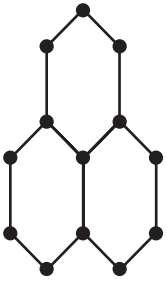

Diagram 1

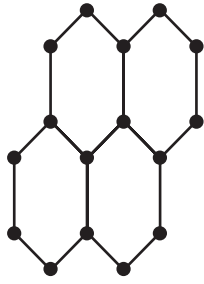

Diagram 2

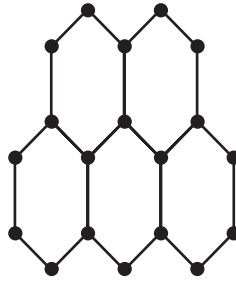

Diagram 3

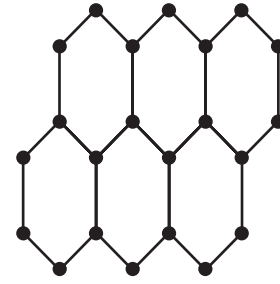

Diagram 4

Look at the sequence of diagrams above.
The number of dots in each diagram is given in the table below.

Diagram number	1	2	3	4	
Number of dots	13	16	19	22	

Find the number of dots in

(a) Diagram 5,

Answer(a) [1]

(b) Diagram 11,

Answer(b) [1]

(c) Diagram n .

Answer(c) [2]

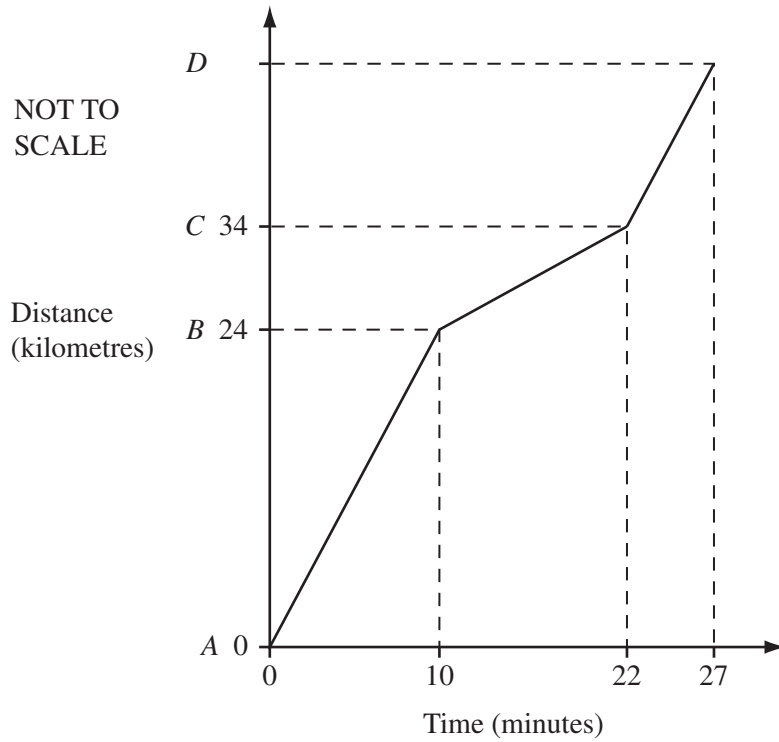

The diagram shows the graph of Rachel's journey on a motorway. Starting at *A*, she drove 24 kilometres to *B* at a constant speed. Between *B* and *C* she had to drive slowly through road works. At *C* she drove a further distance to *D* at her original speed.

(a) For how many minutes was she driving through the road works?

Answer(a) min [1]

(b) At what speed did she drive through the road works?
Give your answer in

(i) kilometres/minute,

Answer(b)(i) km/min [1]

(ii) kilometres/hour.

Answer(b)(ii) km/h [1]

(c) What is the total distance from *A* to *D*?

Answer(c) km [2]

23 Nicolas needs to borrow \$6000 for 3 years. The bank offers him a choice:

*For
Examiner's
Use*

<p>Offer A</p> <p>Interest Rate 7.4% per year</p> <p>Pay the interest at the end of</p> <p>each year</p>
--

<p>Offer B</p> <p>Interest Rate 7% per year</p> <p>Pay all the interest at the end of</p> <p>three years</p>
--

Nicolas recognises that offer A is simple interest and offer B is compound interest.

(a) If he takes offer A, what is the total amount of interest he will pay?

Answer(a) \$ [2]

(b) If he takes offer B, how much **interest** will he pay?
Give your answer correct to 2 decimal places.

Answer(b) \$ [3]

24

$$\mathbf{a} = \begin{pmatrix} 3 \\ -2 \end{pmatrix} \quad \text{and} \quad \mathbf{b} = \begin{pmatrix} -1 \\ 2 \end{pmatrix}$$

For
Examiner's
Use

(a) Work out

(i) $\mathbf{a} + 3\mathbf{b}$,

$$\text{Answer(a)(i)} \quad \begin{pmatrix} \\ \end{pmatrix} \quad [2]$$

(ii) $\mathbf{b} - \mathbf{a}$.

$$\text{Answer(a)(ii)} \quad \begin{pmatrix} \\ \end{pmatrix} \quad [2]$$

(b) $\vec{PQ} = 2\mathbf{b}$.

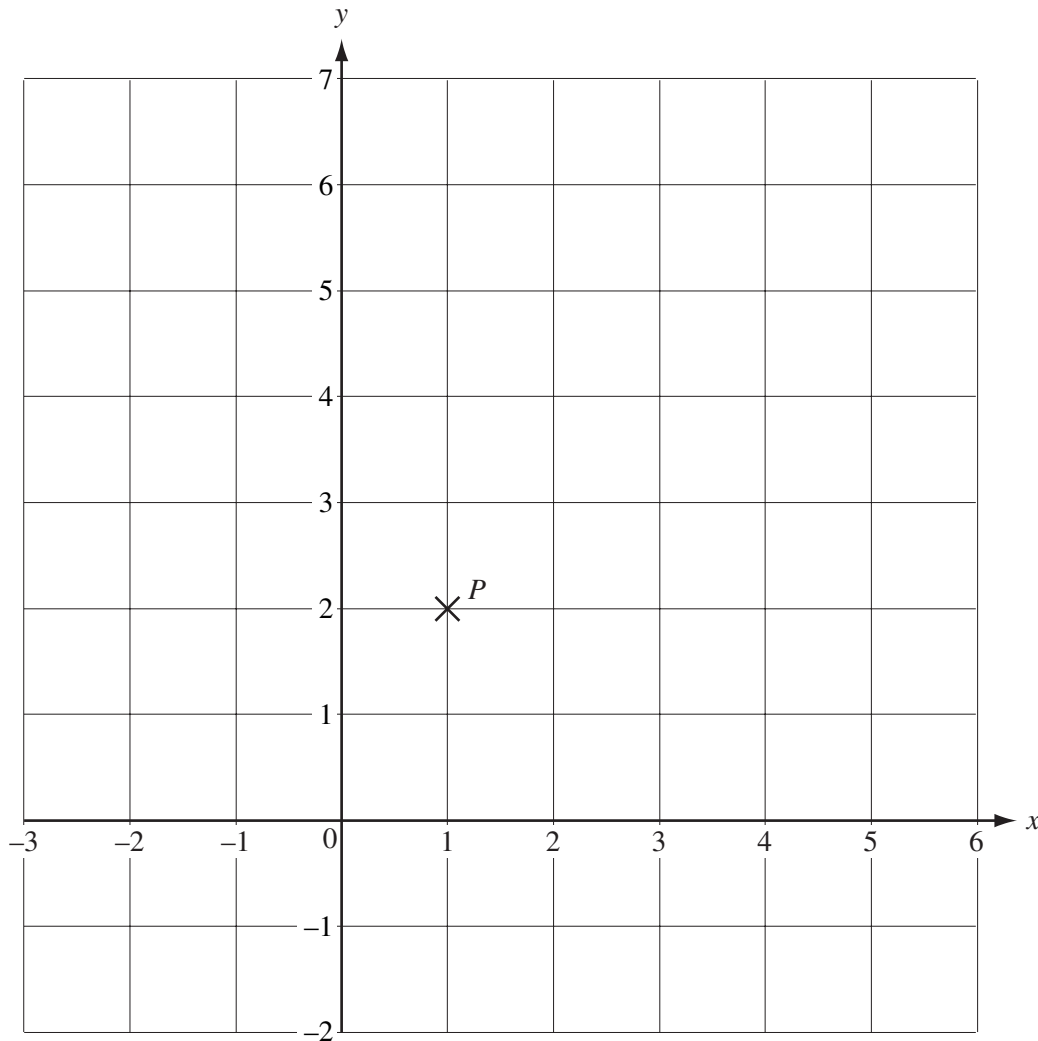
The point P is marked on the grid below.Draw the vector \vec{PQ} on the grid.

[2]

Permission to reproduce items where third-party owned material protected by copyright is included has been sought and cleared where possible. Every reasonable effort has been made by the publisher (UCLES) to trace copyright holders, but if any items requiring clearance have unwittingly been included, the publisher will be pleased to make amends at the earliest possible opportunity.

University of Cambridge International Examinations is part of the Cambridge Assessment Group. Cambridge Assessment is the brand name of University of Cambridge Local Examinations Syndicate (UCLES), which is itself a department of the University of Cambridge.