

Location Entry Codes

As part of CIE's continual commitment to maintaining best practice in assessment, CIE uses different variants of some question papers for our most popular assessments with large and widespread candidature. The question papers are closely related and the relationships between them have been thoroughly established using our assessment expertise. All versions of the paper give assessment of equal standard.

The content assessed by the examination papers and the type of questions is unchanged.

This change means that for this component there are now two variant Question Papers, Mark Schemes and Principal Examiner's Reports where previously there was only one. For any individual country, it is intended that only one variant is used. This document contains both variants which will give all Centres access to even more past examination material than is usually the case.

The diagram shows the relationship between the Question Papers, Mark Schemes and Principal Examiners' Reports that are available.

Question Paper	Mark Scheme	Principal Examiner's Report
Introduction	Introduction	Introduction
First variant Question Paper	First variant Mark Scheme	First variant Principal Examiner's Report
Second variant Question Paper	Second variant Mark Scheme	Second variant Principal Examiner's Report

Who can I contact for further information on these changes?

Please direct any questions about this to CIE's Customer Services team at:

international@cie.org.uk

The titles for the variant items should correspond with the table above, so that at the top of the first page of the relevant part of the document and on the header, it has the words:

- First variant Question Paper / Mark Scheme / Principal Examiner's Report

or

- Second variant Question Paper / Mark Scheme / Principal Examiner's Report

as appropriate.



UNIVERSITY OF CAMBRIDGE INTERNATIONAL EXAMINATIONS
International General Certificate of Secondary Education

CANDIDATE
NAME

CENTRE
NUMBER

--	--	--	--	--

CANDIDATE
NUMBER

--	--	--	--

MATHEMATICS

0580/21, 0581/21

Paper 2 (Extended)

May/June 2008

1 hour 30 minutes

Candidates answer on the Question Paper.

Additional Materials:

Electronic calculator
Mathematical tables (optional)

Geometrical instruments
Tracing paper (optional)

READ THESE INSTRUCTIONS FIRST

Write your Centre number, candidate number and name on all the work you hand in.

Write in dark blue or black pen.

You may use a soft pencil for any diagrams or graphs.

Do not use staples, paper clips, highlighters, glue or correction fluid.

DO NOT WRITE IN ANY BARCODES.

Answer **all** questions.

If working is needed for any question it must be shown below that question.

Electronic calculators should be used.

If the degree of accuracy is not specified in the question, and if the answer is not exact, give the answer to three significant figures. Give answers in degrees to one decimal place.

For π , use either your calculator value or 3.142.

At the end of the examination, fasten all your work securely together.

The number of marks is given in brackets [] at the end of each question or part question.

The total of the marks for this paper is 70.

For Examiner's Use

This document consists of **11** printed pages and **1** blank page.



- 1 Write down the next two prime numbers after 47.

Answer and [2]

- 2 Simplify $\frac{x}{3} + \frac{5x}{9} - \frac{5x}{18}$.

Answer [2]

- 3 Lin scored 18 marks in a test and Jon scored 12 marks.
Calculate Lin's mark as a percentage of Jon's mark.

Answer % [2]

- 4 (a) The formula for the n th term of the sequence

$$1, 5, 14, 30, 55, 91, \dots \text{ is } \frac{n(n+1)(2n+1)}{6}.$$

Find the 20th term.

Answer(a) [1]

- (b) The n th term of the sequence 10, 17, 26, 37, 50, ... is $(n+2)^2 + 1$.

Write down the formula for the n th term of the sequence 17, 26, 37, 50, 65, ...

Answer(b) [1]

- 5 A holiday in Europe was advertised at a cost of €245.
The exchange rate was \$1 = €1.06.
Calculate the cost of the holiday in dollars, giving your answer correct to the nearest cent.

For
Examiner's
Use

Answer \$ [2]

- 6 Write the following in order of size, smallest first.

$$\frac{399}{401} \quad \frac{698}{701} \quad \frac{598}{601}$$

Answer < < [2]

- 7 Write the number 1045.2781 correct to

(a) 2 decimal places,

Answer(a) [1]

(b) 2 significant figures.

Answer(b) [1]

- 8 Simplify $(27x^3)^{\frac{2}{3}}$.

Answer [2]

- 9 A straight line passes through two points with co-ordinates (6, 8) and (0, 5).
Work out the equation of the line.

For
Examiner's
Use

Answer [3]

- 10 A cylindrical glass has a radius of 3 centimetres and a height of 7 centimetres.
A large cylindrical jar full of water is a similar shape to the glass.
The glass can be filled with water from the jar exactly 216 times.
Work out the radius and height of the jar.

Answer radius cm

height cm [3]

11

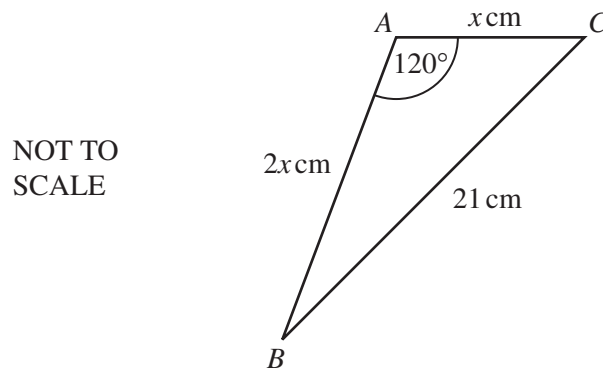

In triangle ABC , $AB = 2x$ cm, $AC = x$ cm, $BC = 21$ cm and angle $BAC = 120^\circ$.
Calculate the value of x .

Answer $x =$ [3]

$$12 \quad \mathcal{E} = \{1,2,3,4,5,6,7,9,11,16\} \quad P = \{2,3,5,7,11\} \quad S = \{1,4,9,16\} \quad M = \{3,6,9\}$$

(a) Draw a Venn diagram to show this information.

[2]

(b) Write down the value of $n(M' \cap P)$.

Answer(b) [1]

13 Solve the inequality

$$\frac{2x-5}{8} > \frac{x+4}{3}.$$

Answer [3]

For
Examiner's
Use

- 14 Sitara has two plants in her school classroom.
 Plant A needs a lot of light and must not be more than 2.5 metres from the window.
 Plant B needs very little light and must be further from the window than from the door.
 For each plant, draw accurately the boundary of the region in which it can be placed.
 In the diagram, 1 centimetre represents 1 metre.



[3]

- 15 Work out

$$\begin{pmatrix} 2 & 1 & 2 \\ 1 & 5 & 0 \\ 3 & -2 & 4 \end{pmatrix} \begin{pmatrix} 4 \\ -3 \\ -8 \end{pmatrix}.$$

Answer [3]

- 16 Find the co-ordinates of the point of intersection of the straight lines

$$\begin{aligned}2x + 3y &= 11, \\3x - 5y &= -12.\end{aligned}$$

*For
Examiner's
Use*

Answer (..... ,) [3]

- 17 A student played a computer game 500 times and won 370 of these games.
He then won the next x games and lost none.
He has now won 75% of the games he has played.
Find the value of x .

Answer $x =$ [4]

18 $f(x) = x^3 - 3x^2 + 6x - 4$ and $g(x) = 2x - 1$.

Find

(a) $f(-1)$,

Answer(a) [1]

(b) $gf(x)$,

Answer(b) [2]

(c) $g^{-1}(x)$.

Answer(c) [2]

*For
Examiner's
Use*

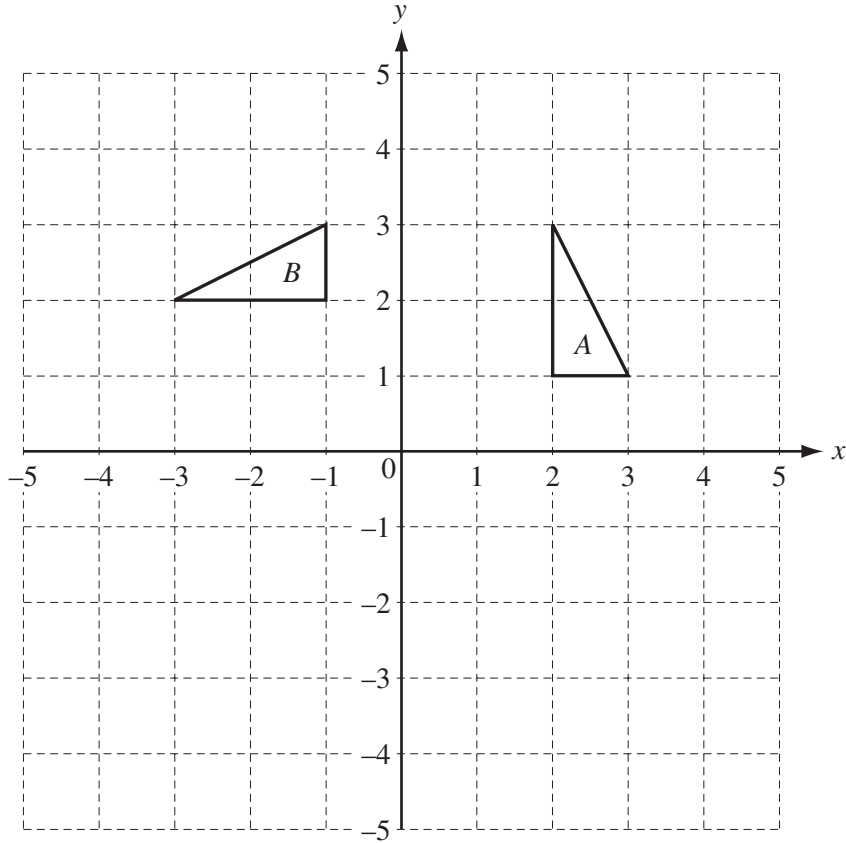

(a) A transformation is represented by the matrix $\begin{pmatrix} 0 & -1 \\ -1 & 0 \end{pmatrix}$.

(i) On the grid above, draw the image of triangle *A* after this transformation.

[2]

(ii) Describe fully this transformation.

Answer(a)(ii) [2]

(b) Find the 2 by 2 matrix representing the transformation which maps triangle *A* onto triangle *B*.

Answer(b) $\begin{pmatrix} & \\ & \end{pmatrix}$ [2]

- 20 The shaded area shows a beach.
 AD and BC are circular arcs, centre O .
 $OB = 160\text{ m}$, $OD = 100\text{ m}$ and angle $AOD = 95^\circ$.

NOT TO SCALE

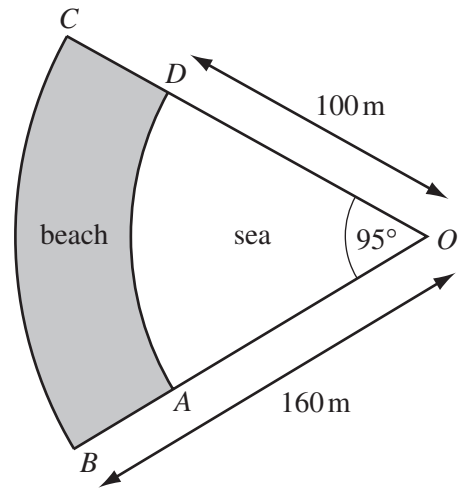

For Examiner's Use

- (a) Calculate the area of the beach $ABCD$ in square metres.

Answer(a) m^2 [3]

- (b) The beach area is covered in sand to a depth of 1.8 m.
 Calculate the volume of the sand in cubic metres.

Answer(b) m^3 [1]

- (c) Write both the following answers in standard form.

- (i) Change your answer to **part(b)** into cubic **millimetres**.

Answer(c)(i) mm^3 [1]

- (ii) Each grain of sand has a volume of 2 mm^3 correct to the nearest mm^3 .

Calculate the maximum possible number of grains of sand on the beach.

Answer(c)(ii) [2]

21

For
Examiner's
Use

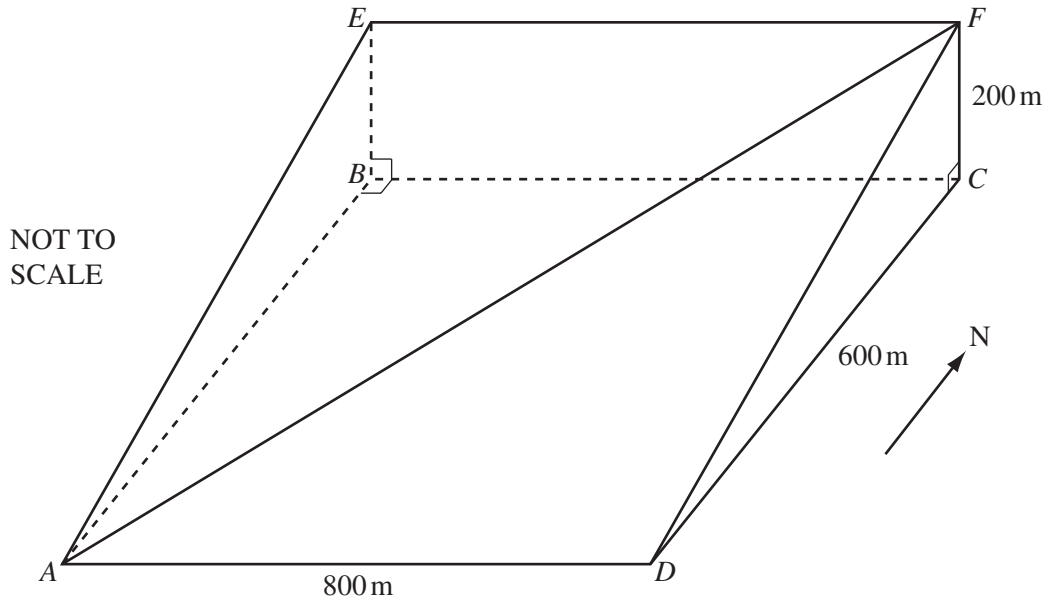

$ABCD$, $BEFC$ and $AEFD$ are all rectangles.
 $ABCD$ is horizontal, $BEFC$ is vertical and $AEFD$ represents a hillside.
 AF is a path on the hillside.
 $AD = 800$ m, $DC = 600$ m and $CF = 200$ m.

(a) Calculate the angle that the path AF makes with $ABCD$.

Answer(a) [5]

(b) In the diagram D is due south of C .
 Jasmine walks down the path from F to A in bad weather. She cannot see the path ahead.
 The compass bearing she must use is the bearing of A from C .
 Calculate this bearing.

Answer(b) [3]

BLANK PAGE

Permission to reproduce items where third-party owned material protected by copyright is included has been sought and cleared where possible. Every reasonable effort has been made by the publisher (UCLES) to trace copyright holders, but if any items requiring clearance have unwittingly been included, the publisher will be pleased to make amends at the earliest possible opportunity.

University of Cambridge International Examinations is part of the Cambridge Assessment Group. Cambridge Assessment is the brand name of University of Cambridge Local Examinations Syndicate (UCLES), which is itself a department of the University of Cambridge.

Second Variant Question Paper



UNIVERSITY OF CAMBRIDGE INTERNATIONAL EXAMINATIONS
International General Certificate of Secondary Education

CANDIDATE NAME

CENTRE NUMBER

--	--	--	--	--

CANDIDATE NUMBER

--	--	--	--



MATHEMATICS

0580/22, 0581/22

Paper 2 (Extended)

May/June 2008

1 hour 30 minutes

Candidates answer on the Question Paper.

Additional Materials: Electronic calculator Geometrical instruments
 Mathematical tables (optional) Tracing paper (optional)

READ THESE INSTRUCTIONS FIRST

- Write your Centre number, candidate number and name on all the work you hand in.
- Write in dark blue or black pen.
- You may use a pencil for any diagrams or graphs.
- Do not use staples, paper clips, highlighters, glue or correction fluid.
- DO NOT WRITE IN ANY BARCODES**

- Answer **all** questions.
- If working is needed for any question it must be shown below that question.
- Electronic calculators should be used.
- If the degree of accuracy is not specified in the question, and if the answer is not exact, give the answer to three significant figures. Give answers in degrees to one decimal place.
- For π , use either your calculator value or 3.142.

- At the end of the examination, fasten all your work securely together.
- The number of marks is given in brackets [] at the end of each question or part question.
- The total of the marks for this paper is 70.

For Examiner's Use

This document consists of **11** printed pages and **1** blank page.

- 1 Write down the next two prime numbers after 53.

Answer and [2]

- 2 Simplify $\frac{x}{3} + \frac{7x}{9} - \frac{7x}{18}$.

Answer [2]

- 3 Lin scored 21 marks in a test and Jon scored 15 marks.
Calculate Lin's mark as a percentage of Jon's mark.

Answer % [2]

- 4 (a) The formula for the n th term of the sequence

$$1, 5, 14, 30, 55, 91, \dots \text{ is } \frac{n(n+1)(2n+1)}{6}.$$

Find the 15th term.

Answer(a) [1]

- (b) The n th term of the sequence 17, 26, 37, 50, 65,... is $(n+3)^2 + 1$.

Write down the formula for the n th term of the sequence 26, 37, 50, 65, 82,...

Answer(b) [1]

- 5 A holiday in Europe was advertised at a cost of €330.
The exchange rate was \$1 = €1.07.
Calculate the cost of the holiday in dollars, giving your answer correct to the nearest cent.

For
Examiner's
Use

Answer \$ [2]

- 6 Write the following in order of size, smallest first.

$$\frac{399}{401} \quad \frac{598}{601} \quad \frac{698}{701}$$

Answer < < [2]

- 7 Write the number 2045.4893 correct to

(a) 2 decimal places,

Answer(a) [1]

(b) 2 significant figures.

Answer(b) [1]

- 8 Simplify $(16x^4)^{\frac{3}{4}}$.

Answer [2]

- 9 A straight line passes through two points with co-ordinates (6,10) and (0, 7).
Work out the equation of the line.

For
Examiner's
Use

Answer [3]

- 10 A cylindrical glass has a radius of 4 centimetres and a height of 6 centimetres.
A large cylindrical jar full of water is a similar shape to the glass.
The glass can be filled with water from the jar exactly 216 times.
Work out the radius and height of the jar.

Answer radius cm

height cm [3]

11

NOT TO
SCALE

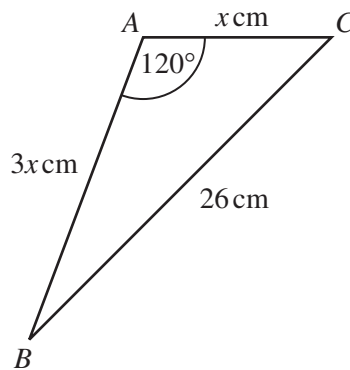

In triangle ABC , $AB = 3x$ cm, $AC = x$ cm, $BC = 26$ cm and angle $BAC = 120^\circ$.
Calculate the value of x .

Answer $x =$ [3]

$$12 \quad \mathcal{E} = \{1,2,3,4,5,6,7,9,11,16\} \quad P = \{2,3,5,7,11\} \quad S = \{1,4,9,16\} \quad M = \{3,6,9\}$$

(a) Draw a Venn diagram to show this information.

[2]

(b) Write down the value of $n(M' \cap P)$.

Answer(b) [1]

13 Solve the inequality

$$\frac{2x-5}{8} > \frac{x+4}{3}.$$

Answer [3]

For
Examiner's
Use

- 14 Sitara has two plants in her school classroom.
 Plant A needs a lot of light and must not be more than 2.5 metres from the window.
 Plant B needs very little light and must be further from the window than from the door.
 For each plant, draw accurately the boundary of the region in which it can be placed.
 In the diagram, 1 centimetre represents 1 metre.



[3]

- 15 Work out

$$\begin{pmatrix} 2 & 1 & 2 \\ 1 & 5 & 0 \\ 3 & -2 & 4 \end{pmatrix} \begin{pmatrix} 4 \\ -3 \\ -8 \end{pmatrix}.$$

Answer [3]

- 16 Find the co-ordinates of the point of intersection of the straight lines

$$\begin{aligned}2x + 3y &= 11, \\3x - 5y &= -12.\end{aligned}$$

*For
Examiner's
Use*

Answer (..... ,) [3]

- 17 A student played a computer game 500 times and won 370 of these games.
He then won the next x games and lost none.
He has now won 75% of the games he has played.
Find the value of x .

Answer $x =$ [4]

18 $f(x) = x^3 - 3x^2 + 6x - 7$ and $g(x) = 2x - 3$.

Find

(a) $f(-1)$,

Answer(a) [1]

(b) $gf(x)$,

Answer(b) [2]

(c) $g^{-1}(x)$.

Answer(c) [2]

*For
Examiner's
Use*

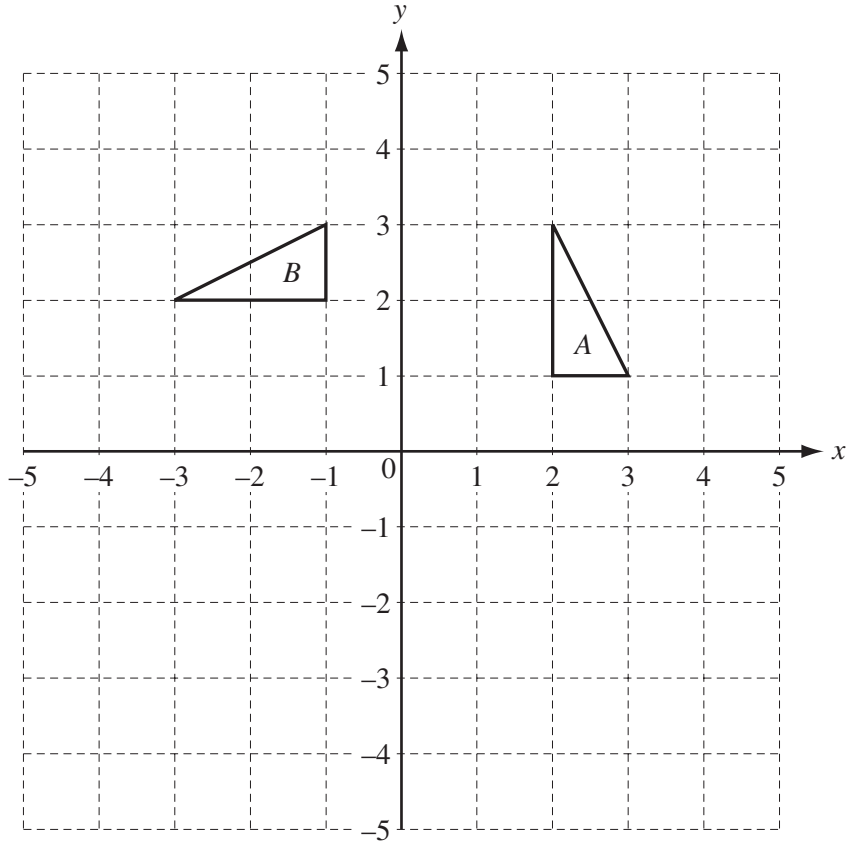

(a) A transformation is represented by the matrix $\begin{pmatrix} 0 & -1 \\ -1 & 0 \end{pmatrix}$.

(i) On the grid above, draw the image of triangle *A* after this transformation.

[2]

(ii) Describe fully this transformation.

Answer(a)(ii) [2]

(b) Find the 2 by 2 matrix representing the transformation which maps triangle *A* onto triangle *B*.

Answer(b) $\begin{pmatrix} & \\ & \end{pmatrix}$ [2]

- 20 The shaded area shows a beach.
 AD and BC are circular arcs, centre O .
 $OB = 160\text{ m}$, $OD = 100\text{ m}$ and angle $AOD = 95^\circ$.

NOT TO SCALE

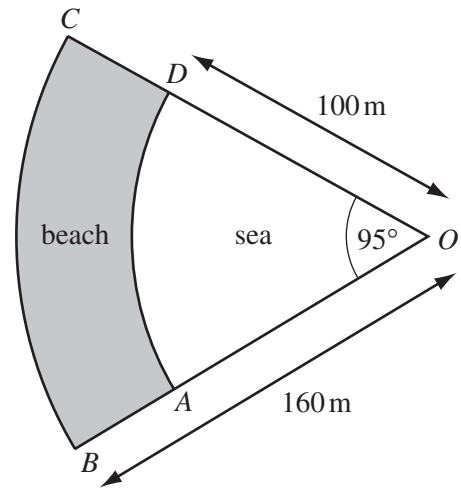

For Examiner's Use

- (a) Calculate the area of the beach $ABCD$ in square metres.

Answer(a) m² [3]

- (b) The beach area is covered in sand to a depth of 1.8 m.
 Calculate the volume of the sand in cubic metres.

Answer(b) m³ [1]

- (c) Write both the following answers in standard form.

- (i) Change your answer to **part(b)** into cubic **millimetres**.

Answer(c)(i) mm³ [1]

- (ii) Each grain of sand has a volume of 2 mm^3 correct to the nearest mm^3 .

Calculate the maximum possible number of grains of sand on the beach.

Answer(c)(ii) [2]

21

For
Examiner's
Use

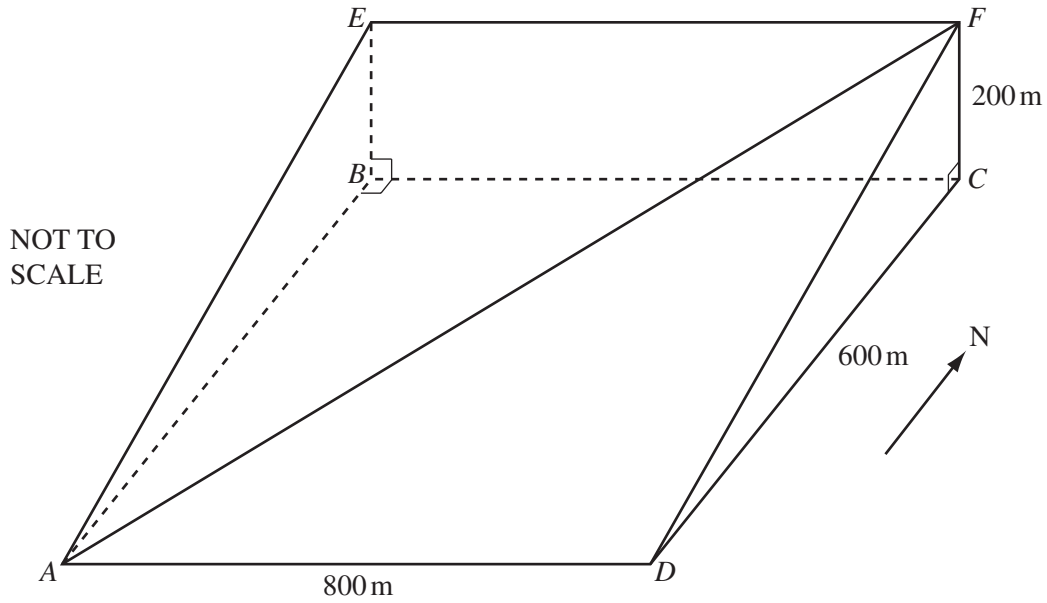

$ABCD$, $BEFC$ and $AEFD$ are all rectangles.
 $ABCD$ is horizontal, $BEFC$ is vertical and $AEFD$ represents a hillside.
 AF is a path on the hillside.
 $AD = 800$ m, $DC = 600$ m and $CF = 200$ m.

(a) Calculate the angle that the path AF makes with $ABCD$.

Answer(a) [5]

(b) In the diagram D is due south of C .
 Jasmine walks down the path from F to A in bad weather. She cannot see the path ahead.
 The compass bearing she must use is the bearing of A from C .
 Calculate this bearing.

Answer(b) [3]

BLANK PAGE

Permission to reproduce items where third-party owned material protected by copyright is included has been sought and cleared where possible. Every reasonable effort has been made by the publisher (UCLES) to trace copyright holders, but if any items requiring clearance have unwittingly been included, the publisher will be pleased to make amends at the earliest possible opportunity.

University of Cambridge International Examinations is part of the Cambridge Assessment Group. Cambridge Assessment is the brand name of University of Cambridge Local Examinations Syndicate (UCLES), which is itself a department of the University of Cambridge.