



UNIVERSITY OF CAMBRIDGE INTERNATIONAL EXAMINATIONS
International General Certificate of Secondary Education

CANDIDATE
NAME

CENTRE
NUMBER

--	--	--	--	--

CANDIDATE
NUMBER

--	--	--	--

* 1 1 0 8 6 3 6 0 5 1 *

MATHEMATICS

0580/42

Paper 4 (Extended)

October/November 2011

2 hours 30 minutes

Candidates answer on the Question Paper.

Additional Materials:

Electronic calculator
Mathematical tables (optional)

Geometrical instruments
Tracing paper (optional)

READ THESE INSTRUCTIONS FIRST

Write your Centre number, candidate number and name on all the work you hand in.

Write in dark blue or black pen.

You may use a pencil for any diagrams or graphs.

Do not use staples, paper clips, highlighters, glue or correction fluid.

DO NOT WRITE IN ANY BARCODES.

Answer **all** questions.

If working is needed for any question it must be shown below that question.

Electronic calculators should be used.

If the degree of accuracy is not specified in the question, and if the answer is not exact, give the answer to three significant figures. Give answers in degrees to one decimal place.

For π use either your calculator value or 3.142.

At the end of the examination, fasten all your work securely together.

The number of marks is given in brackets [] at the end of each question or part question.

The total of the marks for this paper is 130.

This document consists of **19** printed pages and **1** blank page.



1 Children go to camp on holiday.

(a) Fatima buys bananas and apples for the camp.

(i) Bananas cost \$0.85 per kilogram.

Fatima buys 20kg of bananas and receives a discount of 14%.

How much does she spend on bananas?

Answer(a)(i) \$ [3]

(ii) Fatima spends \$16.40 on apples after a discount of 18%.

Calculate the original price of the apples.

Answer(a)(ii) \$ [3]

(iii) The ratio number of bananas : number of apples = 4 : 5.

There are 108 bananas.

Calculate the number of apples.

Answer(a)(iii) [2]

- (b) The cost to hire a tent consists of two parts.

$$\boxed{\$c} + \boxed{\$d \text{ per day}}$$

The total cost for 4 days is \$27.10 and for 7 days is \$34.30.

Write down two equations in c and d and solve them.

$$\begin{aligned} \text{Answer(b) } c &= \dots\dots\dots \\ d &= \dots\dots\dots \end{aligned} \quad [4]$$

- (c) The children travel 270 km to the camp, leaving at 07 43 and arriving at 15 13.

Calculate their average speed in km/h.

$$\text{Answer(c) } \dots\dots\dots \text{ km/h} \quad [3]$$

- (d) Two years ago \$540 was put in a savings account to pay for the holiday.

The account paid **compound** interest at a rate of 6% per year.

How much is in the account now?

$$\text{Answer(d) } \$ \dots\dots\dots \quad [2]$$

For
Examiner's
Use

$$f(x) = 4x - 2$$

$$g(x) = \frac{2}{x} + 1$$

$$h(x) = x^2 + 3$$

(a) (i) Find the value of $hf(2)$.

Answer(a)(i) [2]

(ii) Write $fg(x)$ in its simplest form.

Answer(a)(ii) $fg(x) =$ [2]

(b) Solve $g(x) = 0.2$.

Answer(b) $x =$ [2]

(c) Find the value of $gg(3)$.

Answer(c) [2]

(d) (i) Show that $f(x) = g(x)$ can be written as $4x^2 - 3x - 2 = 0$.

Answer (d)(i)

*For
Examiner's
Use*

[1]

(ii) Solve the equation $4x^2 - 3x - 2 = 0$.

Show all your working and give your answers correct to 2 decimal places.

Answer(d)(ii) $x =$ or $x =$ [4]

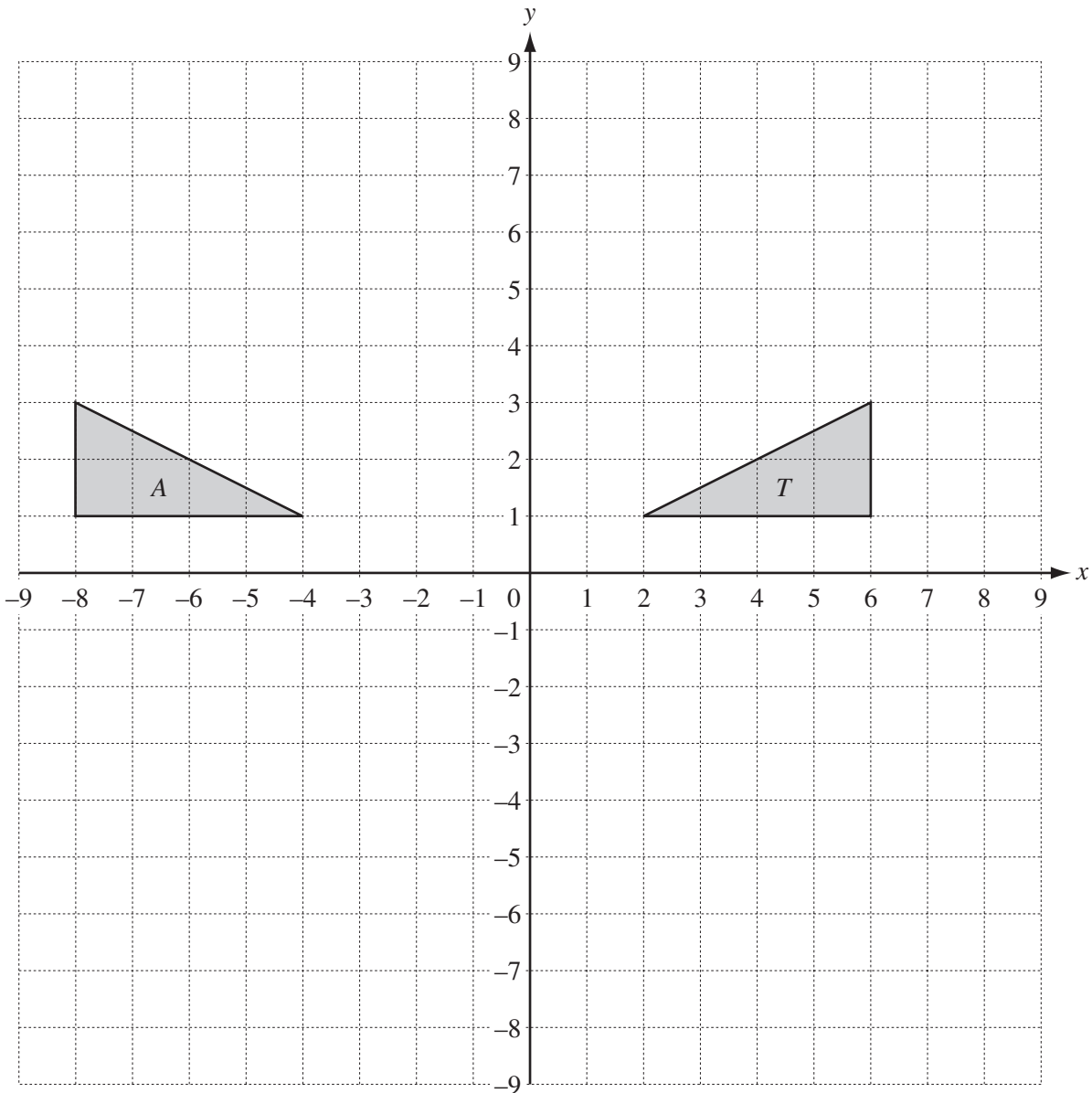

Triangles T and A are drawn on the grid above.

- (a) Describe fully the **single** transformation that maps triangle T onto triangle A .

Answer(a) [2]

- (b) (i) Draw the image of triangle T after a rotation of 90° anticlockwise about the point $(0,0)$.

Label the image B . [2]

- (ii) Draw the image of triangle T after a reflection in the line $x + y = 0$.

Label the image C . [2]

- (iii) Draw the image of triangle T after an enlargement with centre $(4, 5)$ and scale factor 1.5.

Label the image D . [2]

- (c) (i) Triangle T has its vertices at co-ordinates $(2, 1)$, $(6, 1)$ and $(6, 3)$.

Transform triangle T by the matrix $\begin{pmatrix} 1 & 0 \\ 1 & 1 \end{pmatrix}$.

Draw this image on the grid and label it E .

For
Examiner's
Use

- (ii) Describe fully the **single** transformation represented by the matrix $\begin{pmatrix} 1 & 0 \\ 1 & 1 \end{pmatrix}$. [3]

Answer(c)(ii) [3]

- (d) Write down the matrix that transforms triangle B onto triangle T .

Answer(d) $\begin{pmatrix} & \\ & \end{pmatrix}$ [2]

- 4 Boris has a recipe which makes 16 biscuits.

The ingredients are

160 g flour,

160 g sugar,

240 g butter,

200 g oatmeal.

- (a) Boris has only 350 grams of oatmeal but plenty of the other ingredients.

- (i) How many biscuits can he make?

Answer(a)(i) [2]

- (ii) How many grams of butter does he need to make this number of biscuits?

Answer(a)(ii) g [2]

- (b) The ingredients are mixed together to make dough.

This dough is made into a sphere of volume 1080 cm^3 .

Calculate the radius of this sphere.

[The volume, V , of a sphere of radius r is $V = \frac{4}{3} \pi r^3$.]

Answer(b) cm [3]

(c)

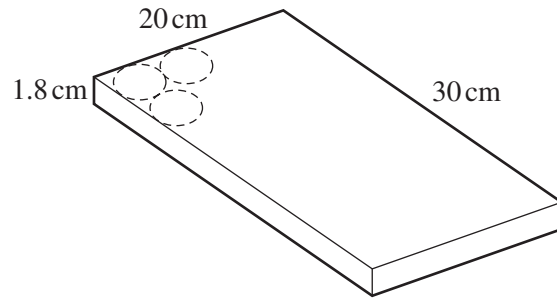
NOT TO
SCALEFor
Examiner's
Use

The 1080 cm^3 of dough is then rolled out to form a cuboid $20 \text{ cm} \times 30 \text{ cm} \times 1.8 \text{ cm}$.

Boris cuts out circular biscuits of diameter 5 cm.

(i) How many whole biscuits can he cut from this cuboid?

Answer(c)(i) [1]

(ii) Calculate the volume of dough left over.

Answer(c)(ii) cm^3 [3]

5 (a) The times, t seconds, for 200 people to solve a problem are shown in the table.

For
Examiner's
Use

Time (t seconds)	Frequency
$0 < t \leq 20$	6
$20 < t \leq 40$	12
$40 < t \leq 50$	20
$50 < t \leq 60$	37
$60 < t \leq 70$	42
$70 < t \leq 80$	50
$80 < t \leq 90$	28
$90 < t \leq 100$	5

Calculate an estimate of the mean time.

Answer(a) s [4]

(b) (i) Complete the cumulative frequency table for this data.

Time (t seconds)	$t \leq 20$	$t \leq 40$	$t \leq 50$	$t \leq 60$	$t \leq 70$	$t \leq 80$	$t \leq 90$	$t \leq 100$
Cumulative Frequency	6	18	38			167		

[2]

(ii) Draw the cumulative frequency graph on the grid opposite to show this data. [4]

(c) Use your cumulative frequency graph to find

(i) the median time,

Answer(c)(i) s [1]

(ii) the lower quartile,

Answer(c)(ii) s [1]

(iii) the inter-quartile range,

Answer(c)(iii) s [1]

(iv) how many people took between 65 and 75 seconds to solve the problem,

Answer(c)(iv) [1]

(v) how many people took longer than 45 seconds to solve the problem.

Answer(c)(v) [2]

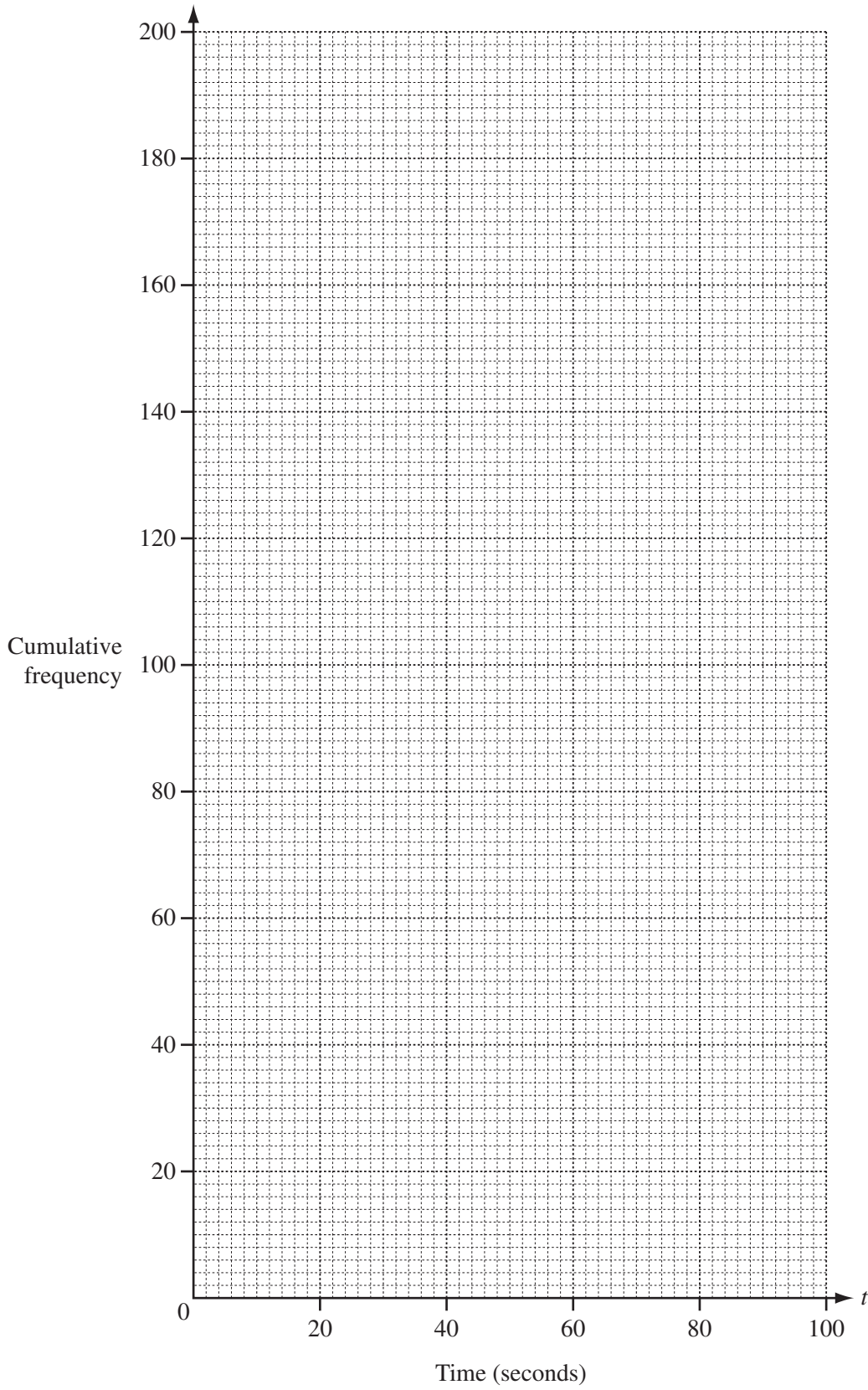

6

For
Examiner's
Use

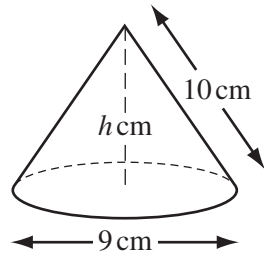

NOT TO
SCALE

A solid cone has diameter 9 cm, slant height 10 cm and vertical height h cm.

- (a) (i) Calculate the curved surface area of the cone.
[The curved surface area, A , of a cone, radius r and slant height l is $A = \pi r l$.]

Answer(a)(i) cm² [2]

- (ii) Calculate the value of h , the vertical height of the cone.

Answer(a)(ii) $h =$ [3]

(b)

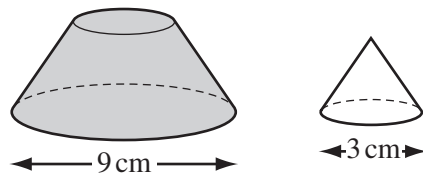

NOT TO
SCALE

Sasha cuts off the top of the cone, making a smaller cone with diameter 3 cm.
This cone is **similar** to the original cone.

- (i) Calculate the **vertical** height of this small cone.

Answer(b)(i) cm [2]

(ii) Calculate the curved surface area of this small cone.

For
Examiner's
Use

Answer(b)(ii) cm² [2]

(c)

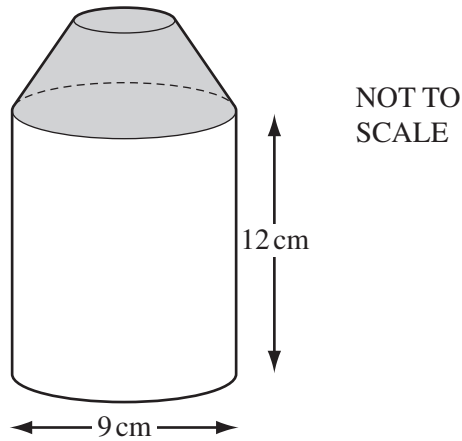

The shaded solid from **part (b)** is joined to a solid cylinder with diameter 9 cm and height 12 cm.
Calculate the **total** surface area of the whole solid.

Answer(c) cm² [5]

- 7 The diagram shows the accurate graph of $y = f(x)$ where $f(x) = \frac{1}{x} + x^2$ for $0 < x \leq 3$.

For
Examiner's
Use

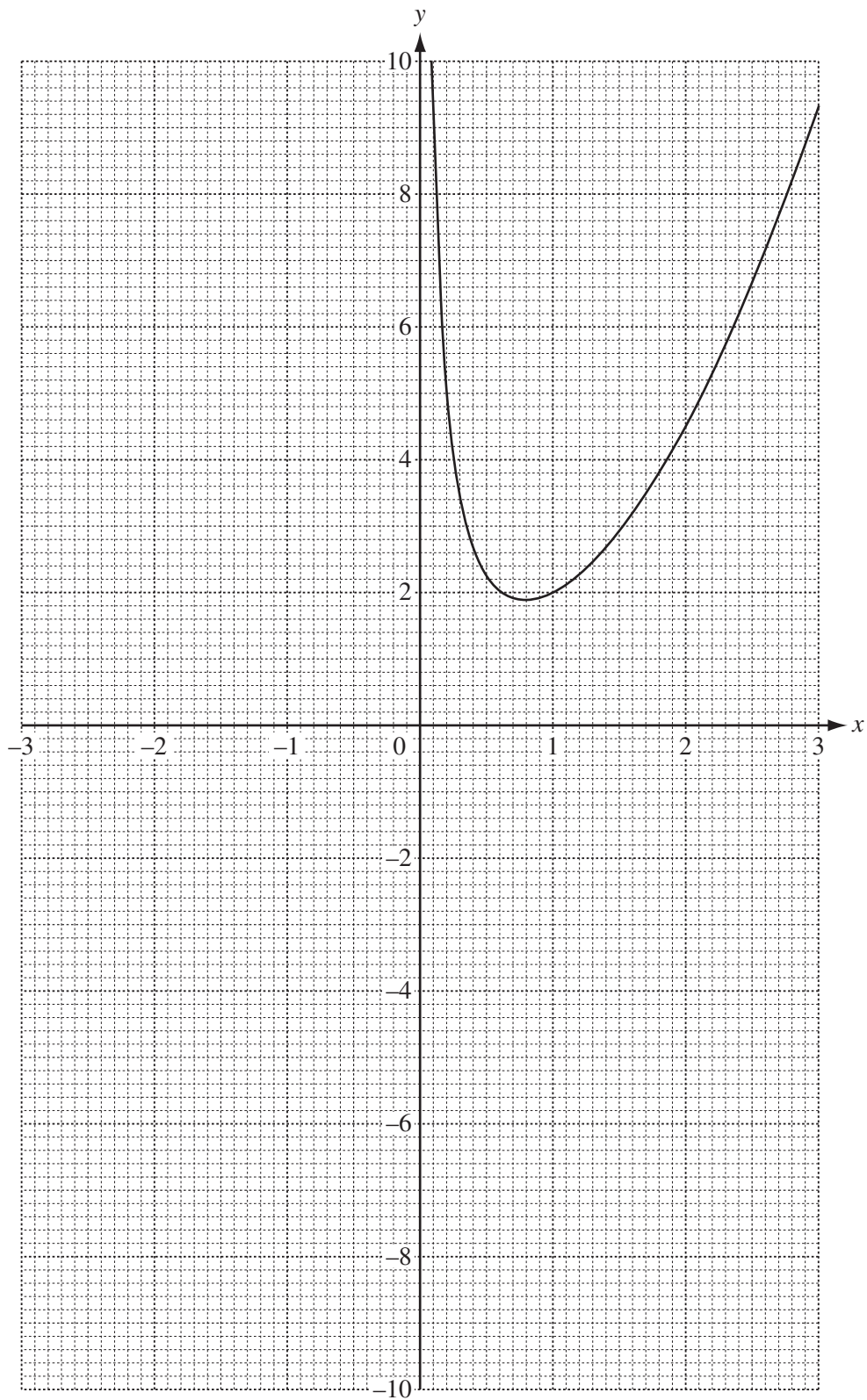

(a) Complete the table for $f(x) = \frac{1}{x} + x^2$.

x	-3	-2	-1	-0.5	-0.3	-0.1
$f(x)$		3.5	0	-1.8		

[3]

(b) On the grid, draw the graph of $y = f(x)$ for $-3 \leq x < 0$.

[3]

(c) By drawing a tangent, work out an estimate of the gradient of the graph where $x = 2$.

Answer(c) [3]

(d) Write down the inequality satisfied by k when $f(x) = k$ has three answers.

Answer(d) [1]

(e) (i) Draw the line $y = 1 - x$ on the grid for $-3 \leq x \leq 3$.

[2]

(ii) Use your graphs to solve the equation $1 - x = \frac{1}{x} + x^2$.

Answer(e)(ii) $x =$ [1]

(f) (i) Rearrange $x^3 - x^2 - 2x + 1 = 0$ into the form $\frac{1}{x} + x^2 = ax + b$, where a and b are integers.

Answer(f)(i)

[2]

(ii) Write down the equation of the line that could be drawn on the graph to solve $x^3 - x^2 - 2x + 1 = 0$.

Answer(f)(ii) $y =$ [1]

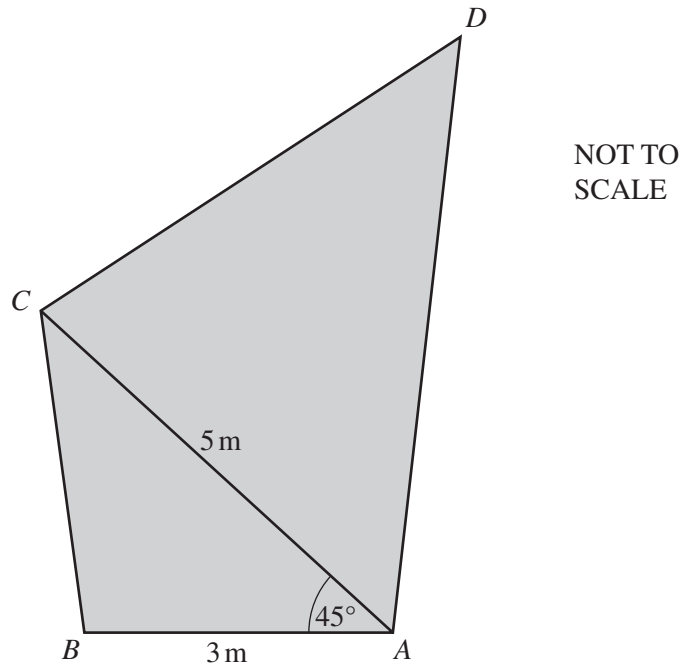

Parvatti has a piece of canvas $ABCD$ in the shape of an irregular quadrilateral.

$AB = 3$ m, $AC = 5$ m and angle $BAC = 45^\circ$.

- (a) (i) Calculate the length of BC and show that it rounds to 3.58 m, correct to 2 decimal places.

You must show all your working.

Answer(a)(i)

[4]

- (ii) Calculate angle BCA .

Answer(a)(ii) Angle $BCA = \dots\dots\dots$ [3]

(b) $AC = CD$ and angle $CDA = 52^\circ$.

(i) Find angle DCA .

Answer(b)(i) Angle $DCA = \dots\dots\dots$ [1]

(ii) Calculate the area of the canvas.

Answer(b)(ii) $\dots\dots\dots$ m² [3]

(c) Parvatti uses the canvas to give some shade.

She attaches corners A and D to the top of vertical poles, AP and DQ , each of height 2 m.

Corners B and C are pegged to the horizontal ground.

AB is a straight line and angle $BPA = 90^\circ$.

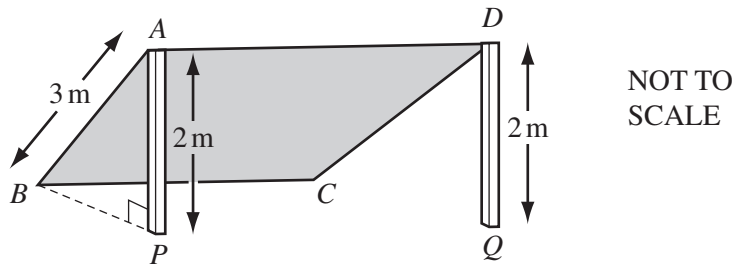

Calculate angle PAB .

Answer(c) Angle $PAB = \dots\dots\dots$ [2]

- 9 (a) Emile lost 2 blue buttons from his shirt.

A bag of spare buttons contains 6 white buttons and 2 blue buttons.

Emile takes 3 buttons out of the bag at random **without replacement**.

Calculate the probability that

- (i) all 3 buttons are white,

Answer(a)(i) [3]

- (ii) exactly one of the 3 buttons is blue.

Answer(a)(ii) [3]

(b) There are 25 buttons in another bag.

This bag contains x blue buttons.

Two buttons are taken at random **without replacement**.

The probability that they are both blue is $\frac{7}{100}$.

(i) Show that $x^2 - x - 42 = 0$.

Answer (b)(i)

(ii) Factorise $x^2 - x - 42$.

[4]

Answer(b)(ii) [2]

(iii) Solve the equation $x^2 - x - 42 = 0$.

Answer(b)(iii) $x =$ or $x =$ [1]

(iv) Write down the number of buttons in the bag which are **not** blue.

Answer(b)(iv) [1]

BLANK PAGE

Permission to reproduce items where third-party owned material protected by copyright is included has been sought and cleared where possible. Every reasonable effort has been made by the publisher (UCLES) to trace copyright holders, but if any items requiring clearance have unwittingly been included, the publisher will be pleased to make amends at the earliest possible opportunity.

University of Cambridge International Examinations is part of the Cambridge Assessment Group. Cambridge Assessment is the brand name of University of Cambridge Local Examinations Syndicate (UCLES), which is itself a department of the University of Cambridge.