



Cambridge International Examinations
Cambridge International General Certificate of Secondary Education

CANDIDATE
NAME

--

CENTRE
NUMBER

--	--	--	--	--

CANDIDATE
NUMBER

--	--	--	--

MATHEMATICS

0580/03

Paper 3 (Core)

For Examination from 2015

SPECIMEN PAPER

2 hours

Candidates answer on the Question Paper.

Additional Materials: Electronic calculator
 Tracing paper (optional)

Geometrical instruments

READ THESE INSTRUCTIONS FIRST

Write your Centre number, candidate number and name on all the work you hand in.

Write in dark blue or black pen.

You may use an HB pencil for any diagrams or graphs.

Do not use staples, paper clips, glue or correction fluid.

Answer **all** questions.

If working is needed for any question it must be shown below that question.

Electronic calculators should be used.

If the degree of accuracy is not specified in the question, and if the answer is not exact, give the answer to three significant figures. Give answers in degrees to one decimal place.

For π , use either your calculator value or 3.142.

At the end of the examination, fasten all your work securely together.

The number of marks is given in brackets [] at the end of each question or part question.

The total of the marks for this paper is 104.

The syllabus is approved for use in England, Wales and Northern Ireland as a Cambridge International Level 1/Level 2 Certificate.

This document consists of **16** printed pages.

- 1 (a) Write twenty five million in figures.

Answer(a) [1]

- (b) Write the following in order of size, starting with the smallest.

$$\frac{2}{3} \quad 65\% \quad 0.6$$

Answer(b) < < [1]

- (c) In a sale a coat costing \$250 is reduced to \$200.

Find the percentage decrease in the cost.

Answer(c) % [3]

- (d)

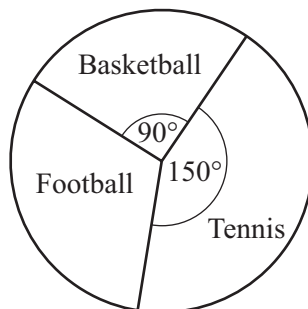

NOT TO
SCALE

120 students are asked to choose their favourite sport.
The results are shown in the pie chart.

Calculate the number of students who chose

- (i) basketball,

Answer(d)(i) [1]

- (ii) football.

Answer(d)(ii) [2]

2 The distance between Geneva and Gstaad is 150 km.

(a) Write 150 in standard form.

Answer(a) [1]

(b) A car took $1\frac{1}{2}$ hours to travel from Geneva to Gstaad.

Calculate the average speed of the car.

Answer(b) km/h [1]

(c) A bus left Gstaad at 10 15.
It arrived in Geneva at 12 30.

Calculate the time, in hours and minutes, that the bus took for the journey.

Answer(c) h min [1]

(d) Another bus left Geneva at 13 55.
It travelled at an average speed of 60 km/h.

Find the time it arrived in Gstaad.

Answer(d) [2]

(e) The distance of 150 km is correct to the nearest 10 km.

Complete the statement for the distance, d km, from Geneva to Gstaad.

Answer(e) $\leq d <$ [2]

3 36 29 41 45 15 10 13

Use the numbers in the list above to answer all the following questions.

(a) Write down

(i) two even numbers,

Answer(a)(i) , [1]

(ii) two prime numbers,

Answer(a)(ii) , [2]

(iii) a square number,

Answer(a)(iii) [1]

(iv) two factors of 90.

Answer(a)(iv) , [2]

(b) (i) Calculate the mean of the seven numbers.

Answer(b)(i) [2]

(ii) Find the median.

Answer(b)(ii) [2]

(iii) Find the range.

Answer(b)(iii) [1]

(c) A number from the list is chosen at random.

Find the probability that the number is

(i) even,

Answer(c)(i) [1]

(ii) a multiple of 5.

Answer(c)(ii) [1]

4 (a) Using the exchange rates

$\$1 = 0.70$ Euros and $\$1 = 90$ Yen

change

(i) \$100 to Euros,

Answer(a)(i) Euros [1]

(ii) 100 Yen to dollars.

Answer(a)(ii) \$ [2]

(b) Tania went on holiday to Switzerland.
The exchange rate was $\$1 = 1.04$ Swiss francs (CHF).
She changed \$1500 to Swiss francs and paid 1% commission.

(i) How much commission, in dollars, did she pay?

Answer(b)(i) \$ [1]

(ii) Show that she received CHF 1544.40.

Answer (b)(ii)

[2]

(c) Tania spent CHF 950 on her holiday.
She converted the remaining Swiss francs back into dollars.
She paid CHF 10 to make the exchange.

Calculate the amount, in dollars, Tania received.

Answer(c) \$ [3]

5

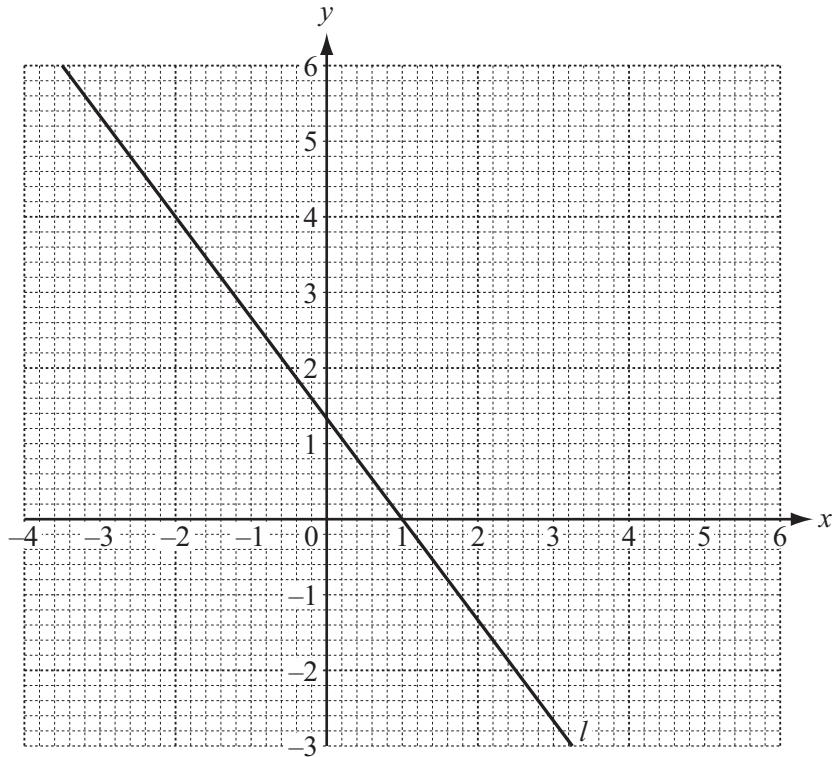

(a) Find the gradient of the line l .

Answer(a) [2]

(b) (i) Complete the table below for $x + 2y = 6$.

x	0	2	
y			0

[3]

(ii) On the grid, draw the line $x + 2y = 6$ for $-4 \leq x \leq 6$.

[2]

(c) The equation of the line l is $4x + 3y = 4$.

Use your diagram to solve the simultaneous equations $4x + 3y = 4$ and $x + 2y = 6$.

Answer(c) $x =$

$y =$ [2]

6 (a)



The line AB is drawn above.

**Parts (i), (iii), and (v) must be completed using a ruler and compasses only.
All construction arcs must be clearly shown.**

(i) Construct triangle ABC with $AC = 7$ cm and $BC = 6$ cm. [2]

(ii) Measure angle BAC .

Answer(a)(ii) Angle $BAC =$ [1]

(iii) Construct the bisector of angle ABC . [2]

(iv) The bisector of angle ABC meets AC at T .

Measure the length of AT .

Answer(a)(iv) $AT =$ cm [1]

(v) Construct the perpendicular bisector of the line BC . [2]

(vi) Shade the region that is

- and**
- nearer to B than to C
 - nearer to BC than to AB . [1]

(b) A ship sails 40 km on a bearing of 040° from P to Q .

- (i) Using a scale of 1 centimetre to represent 5 kilometres, make a scale drawing of the path of the ship.

Mark the point Q .



Scale: 1 cm = 5 km

[2]

- (ii) At Q the ship changes direction and sails 30 km on a bearing of 160° to the point R .

Draw the path of the ship.

[2]

- (iii) Find how far, in kilometres, the ship is from the starting position P .

Answer(b)(iii) km [1]

- (iv) Measure the bearing of P from R .

Answer(b)(iv) [1]

7 (a) Solve the equation $2(x + 4) = 3(x + 2) + 8$.

Answer(a) $x =$ [3]

(b) Make z the subject of $za + b = 3$.

Answer(b) $z =$ [2]

(c) Find x when $2x^3 = 54$.

Answer(c) $x =$ [2]

(d) A rectangular field has a length of x metres.
The width of the field is $(2x - 5)$ metres.

(i) Show that the perimeter of the field is $(6x - 10)$ metres.

Answer (d)(i)

[2]

(ii) The perimeter of the field is 50 metres.

Find the length of the field.

Answer(d)(ii) length = m [2]

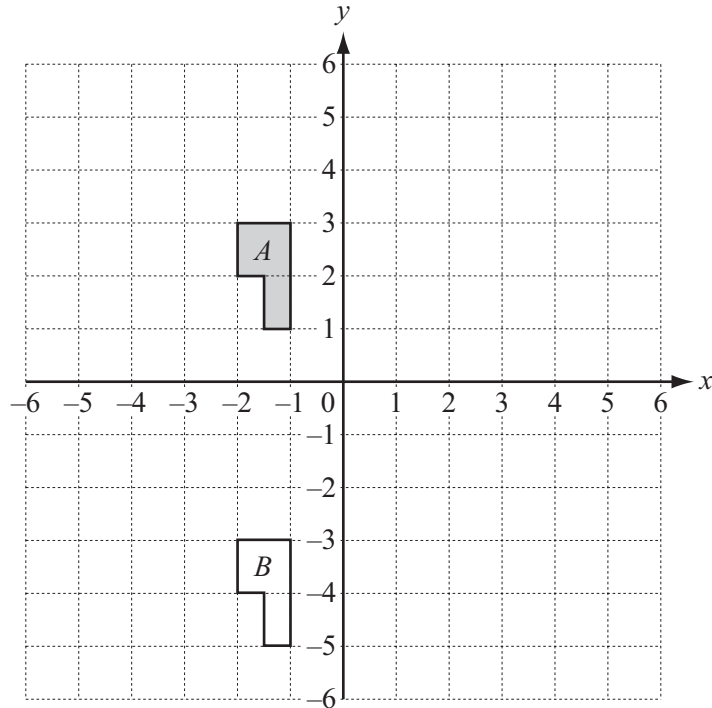

The diagram shows two shapes A and B .

- (a) Describe fully the **single** transformation which maps A onto B .

Answer(a) [2]

- (b) On the grid, draw the line $x = 2$. [1]

- (c) On the grid, draw the image of shape A after the following transformations.

- (i) Reflection in the line $x = 2$. Label the image C . [1]

- (ii) Enlargement, scale factor 2, centre $(0, 0)$. Label the image D . [2]

9 (a) Factorise completely $3x^2 + 12x$.

Answer(a) [2]

(b) Find the value of $a^3 + 3b^2$ when $a = 2$ and $b = -2$.

Answer(b) [2]

(c) Simplify $3x^4 \times 2x^3$.

Answer(c) [2]

10

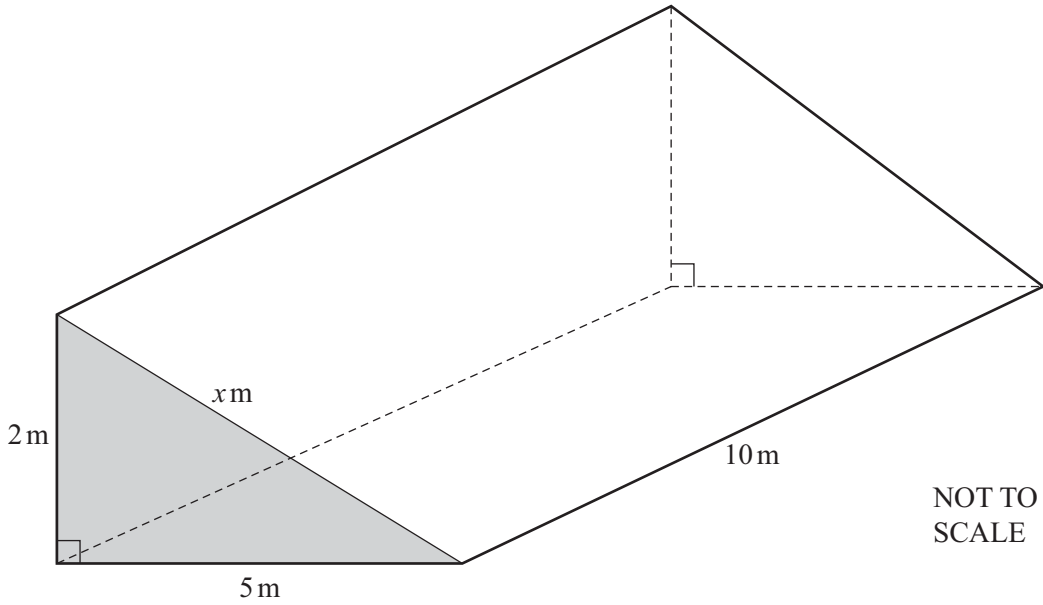

The diagram shows a ramp in the form of a triangular prism.
The cross-section is a right-angled triangle of length 5 m and height 2 m.

- (a) Find the value of x .
Give your answer correct to 1 decimal place.

Answer(a) $x =$ [3]

- (b) Find the area of the cross-section.

Answer(b) m^2 [2]

- (c) The ramp is 10 m long.
Calculate the volume of the ramp.

Answer(c) m^3 [1]

(d) Calculate the total surface area of all five faces of the ramp.

Answer(d) m² [3]

(e) Each face of the ramp is painted.
Paint costs \$2.25 per square metre.

Calculate the total cost of the paint.

Answer(e) \$ [1]

Question 11 is printed on the next page.

11

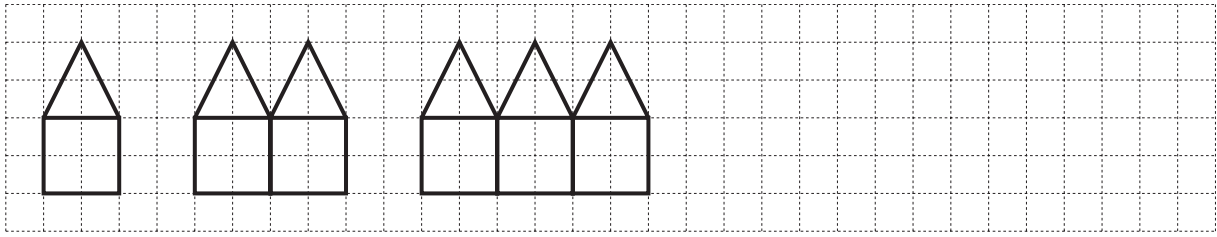

Diagram 1

Diagram 2

Diagram 3

The diagrams show a sequence of shapes.

(a) On the grid, draw Diagram 4.

[1]

(b) Complete the table showing the number of lines in each diagram.

Diagram (n)	Number of lines
1	6
2	11
3	
4	
5	

[3]

(c) Work out the number of lines in Diagram 8.

Answer(c)

[1]

(d) Write down an expression, in terms of n , for the number of lines in Diagram n .

Answer(d)

[2]

(e) Work out the number of lines in Diagram 100.

Answer(e)

[1]

(f) The number of lines in Diagram p is 66.

Find the value of p .

Answer(f) $p =$

[2]

Permission to reproduce items where third-party owned material protected by copyright is included has been sought and cleared where possible. Every reasonable effort has been made by the publisher (UCLES) to trace copyright holders, but if any items requiring clearance have unwittingly been included, the publisher will be pleased to make amends at the earliest possible opportunity.

Cambridge International Examinations is part of the Cambridge Assessment Group. Cambridge Assessment is the brand name of University of Cambridge Local Examinations Syndicate (UCLES), which is itself a department of the University of Cambridge.