

CAMBRIDGE INTERNATIONAL EXAMINATIONS
International General Certificate of Secondary Education

PHYSICS

0625/05

Paper 5 Practical Test

May/June 2003

CONFIDENTIAL INSTRUCTIONS

Great care should be taken that any confidential information given does not reach the candidates either directly or indirectly.

This document consists of **8** printed pages.



Instructions for preparing apparatus

The Supervisor is **not** allowed to consult the Question Paper before the examination. This teacher should, as a part of the preparation of the examination requirements, test the apparatus in order to be satisfied that it functions as required.

The Supervisor is asked to give (and attach to the Report form printed on pages 7 and 8) a *brief* description of the apparatus supplied, mentioning any points which are likely to be of importance to the Examiner in marking the answers. The Supervisor should also report any assistance given to candidates. All reports should be signed by the Supervisor and by the person responsible for preparing the apparatus.

In addition to the usual equipment of a physics laboratory, each candidate will require the apparatus specified in these Instructions. If a candidate breaks any of the apparatus, or loses any of the material supplied, the matter should be rectified and a note made in the Report.

Number of sets of apparatus

As a *minimum*, the number of sets of apparatus provided for each question should be $N/4$, where N is the number of candidates (per session). A few spare sets should, preferably, be available to avoid any candidate being delayed when moving to another question.

Centres may find it more convenient and easier to administer if $N/3$ sets (plus one or two 'spares') of apparatus are provided for each question.

The order in which a given candidate attempts the four questions is immaterial.

Assistance to candidates

The purpose of the Practical Test is to find out whether the candidates can carry out simple practical work themselves. The Examiners are aware that candidates may sometimes be unable to show their practical ability through failure to understand some point in the theory of the experiment. If an Examiner were present in the laboratory, he/she would be willing to give a hint to enable such a candidate to get on with an experiment. In order to overcome this difficulty, the Supervisor is asked to co-operate with the Examiners to the extent of being ready to give (or allow the physics teacher to give) a hint to a candidate who is unable to proceed.

The following regulations must be strictly adhered to.

- (i) No hint may be announced to the candidates as a whole.
- (ii) A candidate who is unable to proceed and requires assistance must come up to the Supervisor and state the difficulty. Candidates should be told that the Examiners will be informed of any assistance given in this way.
- (iii) A report must be made of any assistance given to the candidate, with the name and index number of the candidate.

It is suggested that the following announcement be made to the candidates.

'The Examiners do not want you to waste time through inability to get on with an experiment. Any candidate, therefore, who is unable to get on with the experiment after spending five minutes at it may come to me and ask for help. I shall report to the Examiners any help given in this way, and some marks may be lost for the help given. You may ask me for additional apparatus which you think would improve the accuracy of your experiments, and you should say, on your script, how you use any such apparatus supplied.'

Question 1

Items to be supplied by the Centre (per set of apparatus unless otherwise specified)

- (i) Two $-10^{\circ}\text{C} - 110^{\circ}\text{C}$ thermometers of similar size and type, capable of being read to the nearest 1°C .
- (ii) 12 V, 24 W lamp mounted in a suitable holder with an appropriate power source (a car headlamp bulb is suitable).
- (iii) Two stands, clamps and bosses.
- (iv) A small card suitably mounted to stand vertically (see notes).
- (v) Stopwatch or stopclock.

Notes

1. One thermometer is to be labelled A.
2. The second thermometer is to have a thin layer of cotton wool wrapped around the bulb and held in place with thread. This thermometer is to be labelled B.
3. The thermometers are to be set up in clamps as shown in Fig. 1.1. The thermometer bulbs are to be on opposite sides of the lamp and 1.0 cm from the outside surface of the lamp.
4. A small card can be used to protect candidates from the direct glare of the lamp. The card must not prevent the candidates from observing the thermometer scales.

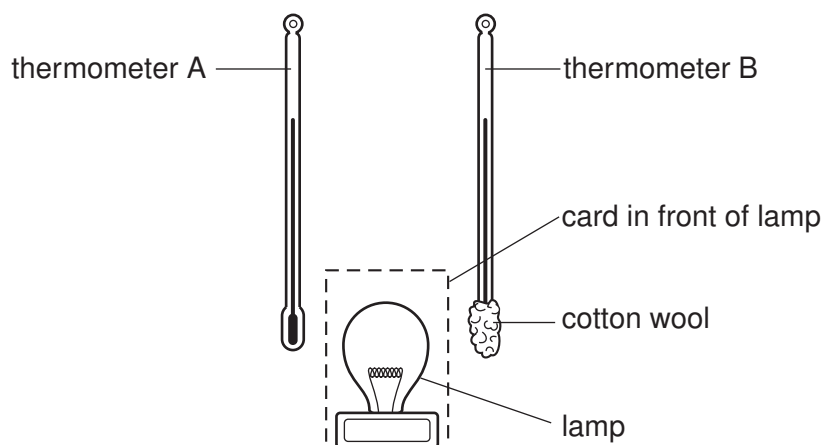

Fig. 1.1

Action at changeover

Check that the lamp and thermometers have cooled. If they have not, supply a replacement set. Check the distances between the lamp and the thermometer bulbs.

Question 2

Items to be supplied by the Centre (per set of apparatus unless otherwise specified)

- (i) Beaker. 250 ml is recommended, but any size will be suitable.
- (ii) Metre rule.
- (iii) Thin string, long enough to go round the beaker six times.
- (iv) Two rectangular blocks or strips of wood. The size of these is not critical but the longest sides should be of length equal to at least twice the diameter of the beaker. The height should be no more than half the height of the beaker. It is important that the blocks or strips of wood have smooth, straight sides.

Note

The blocks or strips of wood are to be used to assist the candidates to measure the external diameter of the beaker.

Action at changeover

None.

Question 3

Items to be supplied by the Centre (per set of apparatus unless otherwise specified)

- (i) Power source of approximately 1.5 – 2.0 V. Where candidates are supplied with a power source with a variable output voltage, the voltage setting should be set by the Supervisor and fixed (e.g. taped).
- (ii) Voltmeter capable of measuring the supply p.d. with a minimum precision of 0.1 V.
- (iii) Ammeter capable of reading up to 1.0 A with a minimum precision of 0.05 A.
- (iv) Two 2.5 V, 0.2 A lamps in suitable holders.
- (v) Switch (this can be an integral part of the power supply).
- (vi) Sufficient connecting leads to set up the circuit shown in Fig. 3.1, plus one additional lead.

Notes

1. The circuit is to be set up for the candidates as shown in Fig. 3.1.
2. The candidates will rearrange the circuit so that the lamps are in parallel.

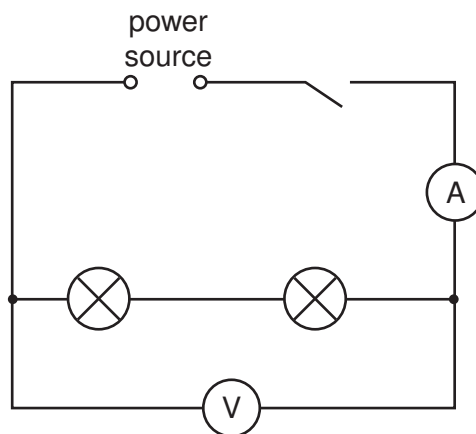

Fig. 3.1

Action at changeover

Reconnect the circuit as shown in Fig. 3.1.

Question 4

Items to be supplied by the Centre (per set of apparatus unless otherwise specified)

- (i) Plane mirror approximately 10 cm × 5 cm or larger.
- (ii) A suitable holder for the mirror so that it can stand with one of its longer edges on the table and its reflecting surface vertical.
- (iii) 4 optics pins.
- (iv) Pin board (e.g. a cork mat) 300 mm × 210 mm or larger.
- (v) 50 cm or 30 cm rule, graduated in mm (candidates may use their own).
- (vi) Protractor (candidates may use their own).

Action at changeover:

None.

This form must be completed and returned with the scripts.

REPORT ON PRACTICAL PHYSICS

(IGCSE MAY/JUNE 2003)

General

The Supervisor is invited to give details of any difficulties experienced by particular candidates giving their names and candidate numbers. These should include reference to:

- (a) difficulties due to faulty apparatus;
- (b) accidents to apparatus or materials;
- (c) any other information that is likely to assist the Examiner, especially if this cannot be discovered in the scripts;
- (d) any help given to a candidate.

Information required

A plan of workbenches, giving details by index number of the places occupied by the candidates for each experiment for each session, must be enclosed with the Answer Booklets.



Information required (cont.)

A list by name and index number of candidates requiring help, with details of the help provided

CENTRE NO.....

NAME OF CENTRE

Declaration (to be signed by the Supervisor and the person responsible for preparing the apparatus)

The preparation of the practical examination has been carried out so as to maintain fully the security of the examination.

SIGNED
Supervisor

SIGNED
Person responsible for preparing the apparatus