

UNIVERSITY OF CAMBRIDGE INTERNATIONAL EXAMINATIONS
International General Certificate of Secondary Education

PHYSICS

0625/05

Paper 5 Practical Test

October/November 2006

CONFIDENTIAL INSTRUCTIONS

Great care should be taken to ensure that any confidential information given does not reach the candidates either directly or indirectly.

If you have any problems or queries regarding these Instructions, please contact CIE
by e-mail: International@cie.org.uk,
by phone: +44 1223 553554,
by fax: +44 1223 553558,
stating the Centre number, the nature of the query and the syllabus number quoted above.

This document consists of **9** printed pages and **3** blank pages.



Instructions for preparing apparatus

The Supervisor is **not** allowed to consult the Question Paper before the examination. This teacher should, as part of the preparation of the examination requirements, test the apparatus in order to ensure that it is satisfactory.

The Supervisor is asked to give (and attach to the Report form printed on pages 11 and 12) a *brief* description of the apparatus supplied, mentioning any points that are likely to be of importance to the Examiner in marking the answers. The Supervisor should also report any assistance given to candidates. All reports should be signed by the Supervisor and by the person responsible for preparing the apparatus.

In addition to the usual equipment of a physics laboratory, each candidate will require the apparatus specified in these Instructions. If a candidate breaks any of the apparatus, or loses any of the material supplied, the matter should be rectified and a note made in the Report.

Number of sets of apparatus

As a *minimum*, the number of sets of apparatus provided should be $N/4$, where N is the number of candidates (per session). A few spare sets should, preferably, be available to avoid any candidate being delayed when moving to another question. Centres may find it more convenient and easier to administer if $N/3$ sets (plus one or two 'spares') of apparatus are provided.

The order in which a given candidate attempts the four questions is immaterial. The four questions are equally weighted and the same length of time should be allowed for each question.

Assistance to Candidates

The purpose of the Practical Physics test is to find out whether the candidates can carry out simple practical work themselves. The Examiners are aware that candidates may sometimes be unable to show their practical ability through failure to understand some point in the theory of the experiment. If an Examiner were present in the laboratory, he/she would be willing to give a hint to enable such a candidate to get on with an experiment. In order to overcome this difficulty, the Supervisor is asked to co-operate with the Examiners to the extent of being ready to give (or allow the Physics teacher to give) a hint to a candidate who is unable to proceed.

The following regulations must be strictly adhered to.

- (i) No hint may be announced to the candidates as a whole.
- (ii) A candidate who is unable to proceed and requires assistance must come up to the Supervisor and state the difficulty. Candidates should be told that the Examiners will be informed of any assistance given in this way.
- (iii) A report must be made of any assistance given to the candidate, with the name and candidate number of the candidate.

It is suggested that the following announcement be made to the candidates.

'The Examiners do not want you to waste time through inability to get on with an experiment. Any candidate, therefore, who is unable to get on with the experiment after spending five minutes at it may come to me and ask for help. I shall report to the Examiners any help given in this way, and some marks may be lost for the help given. You may ask me for additional apparatus which you think would improve the accuracy of your experiments, and you should say, on your script, how you use any such apparatus supplied.'

Question 1**Items to be supplied by the Centre (per set of apparatus unless otherwise specified)**

A bundle of ten wooden rods each of length approximately 8.0 cm and diameter approximately 0.8 cm. The bundle is to be held together with an elastic band.

300 mm or 500 mm rule.

Metre rule.

Thin string of length approximately 1 m.

Balance capable of measuring the mass of the bundle of wooden rods to 1 g.

Notes

1. The rods in each bundle should be made from the same wood. Unsharpened pencils could be used. (The use of hexagonal pencils is acceptable.)
2. It is not necessary to supply a balance for each set of apparatus but candidates must have easy access to a nearby balance.
3. At the changeover, check that the bundle of rods is still held together with the elastic band.

Information required by examiners

None.

Question 2**Items to be supplied by the Centre (per set of apparatus unless otherwise specified)**

Metre rule with a small hole drilled centrally at the 1.0 cm mark. The hole must be large enough to accept the pivot so that the rule swings freely on the pivot.

Optics pin, thin round nail or similar to act as a pivot for the metre rule.

Clamp, stand and boss.

100 g mass.

Elastic band.

Stopwatch reading to 0.2 s or better.

Notes

1. The apparatus should be set up by the Supervisor as shown in Fig. 2.1.
2. The 100 g mass must be held on the rule, using an elastic band, so that its centre of mass is at the 91.0 cm mark.
3. It must be possible for the candidate easily to move the mass to other positions on the rule.
4. If necessary, the base of the stand should be weighted so that there is no danger of it tipping over during the experiment.
5. At the changeover, return the 100 g mass to the 91.0 cm mark.

Information required by examiners

None.

5

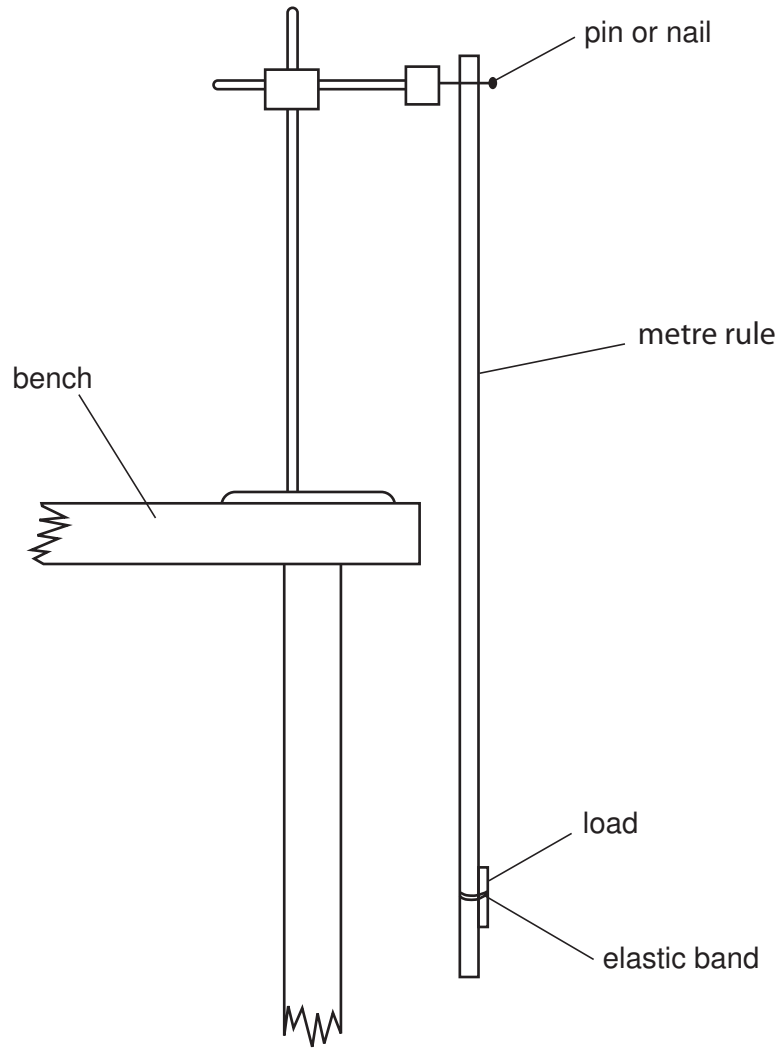

Fig. 2.1

Question 3**Items to be supplied by the Centre (per set of apparatus unless otherwise specified)**

Sheet of plain A4 size paper with a hole in one corner (one per candidate).

Plane mirror with a holder that allows the mirror to stand vertically.

Four optics pins.

Pin board (e.g. a cork mat), A4 size or larger.

Protractor.

50 cm or 30 cm rule, graduated in mm.

String (to tie the plain A4 sheet of paper into the Answer Booklet).

Notes

1. The mirror should be capable of standing vertically with one edge on the sheet of plain A4 paper.
2. Spare sheets of plain paper should be available.
3. At the changeover, supply a new sheet of plain A4 paper.

Information required by examiners

None.

Question 4**Items to be supplied by the Centre (per set of apparatus unless otherwise specified)**

Thermometer, -10°C to 110°C , capable of being read to the nearest 1°C .

250 cm^3 beaker labelled **A**. This beaker is to be insulated with a layer of an insulating material about 0.5 cm thick. Cotton wool is suitable.

250 cm^3 beaker labelled **B**.

Lid to fit beaker **B**. The lid must have a small hole to accept the thermometer. A lid made from card is suitable.

Supply of hot water. Each candidate will require about 400 cm^3 .

Stopwatch or stopclock.

250 cm^3 measuring cylinder.

Notes

1. The hot water is to be supplied for each candidate by the Supervisor. The water temperature should be between 80°C and 100°C .
2. Candidates should be warned of the dangers of burns or scalds when using very hot water.
3. Cloths or tissues should be available in case of spillages.
4. The type and thickness of the insulating material is not critical.
5. At the changeover, empty beaker **B** and the measuring cylinder, replenish the supply of hot water, and replace the insulation or lid if either has become wet.

Information required by examiners

None.

BLANK PAGE

BLANK PAGE

BLANK PAGE

Permission to reproduce items where third-party owned material protected by copyright is included has been sought and cleared where possible. Every reasonable effort has been made by the publisher (UCLES) to trace copyright holders, but if any items requiring clearance have unwittingly been included, the publisher will be pleased to make amends at the earliest possible opportunity.

University of Cambridge International Examinations is part of the University of Cambridge Local Examinations Syndicate (UCLES), which is itself a department of the University of Cambridge.

This form must be completed and returned with the scripts.

REPORT ON PRACTICAL PHYSICS

(IGCSE OCTOBER/NOVEMBER 2006)

General

The Supervisor is invited to give details of any difficulties experienced by particular candidates giving their names and candidate numbers. These should include reference to:

- (a) difficulties due to faulty apparatus;
- (b) accidents to apparatus or materials;
- (c) any other information that is likely to assist the Examiner, especially if this cannot be discovered in the scripts;
- (d) any help given to a candidate.

Information required

A plan of workbenches, giving details by candidate number of the places occupied by the candidates for each experiment for each session, must be enclosed with the Answer Booklets.



Information required (cont.)

A list by name and candidate number of candidates requiring help, with details of the help provided.

CENTRE NO.

NAME OF CENTRE

Declaration (to be signed by the Supervisor and the person responsible for preparing the apparatus)

The preparation of the practical examination has been carried out so as to maintain fully the security of the examination.

SIGNED
Supervisor

SIGNED
Person responsible for preparing the apparatus

