



UNIVERSITY OF CAMBRIDGE INTERNATIONAL EXAMINATIONS
International General Certificate of Secondary Education

PHYSICS

0625/01

Paper 1 Multiple Choice

October/November 2007

45 minutes

Additional Materials: Multiple Choice Answer Sheet
 Soft clean eraser
 Soft pencil (type B or HB is recommended)



READ THESE INSTRUCTIONS FIRST

Write in soft pencil.

Do not use staples, paper clips, highlighters, glue or correction fluid.

Write your name, Centre number and candidate number on the Answer Sheet in the spaces provided unless this has been done for you.

There are forty questions on this paper. Answer all questions. For each question there are four possible answers A, B, C, and D.

Choose the one you consider correct and record your choice in soft pencil on the separate Answer Sheet.

Read the instructions on the Answer Sheet very carefully.

Each correct answer will score one mark. A mark will not be deducted for a wrong answer.

Any rough working should be done in this booklet.

This document consists of **18** printed pages and **2** blank pages.



- 1 Some water is poured into four tubes of different cross-sectional areas.

Which tube contains the largest volume of water?

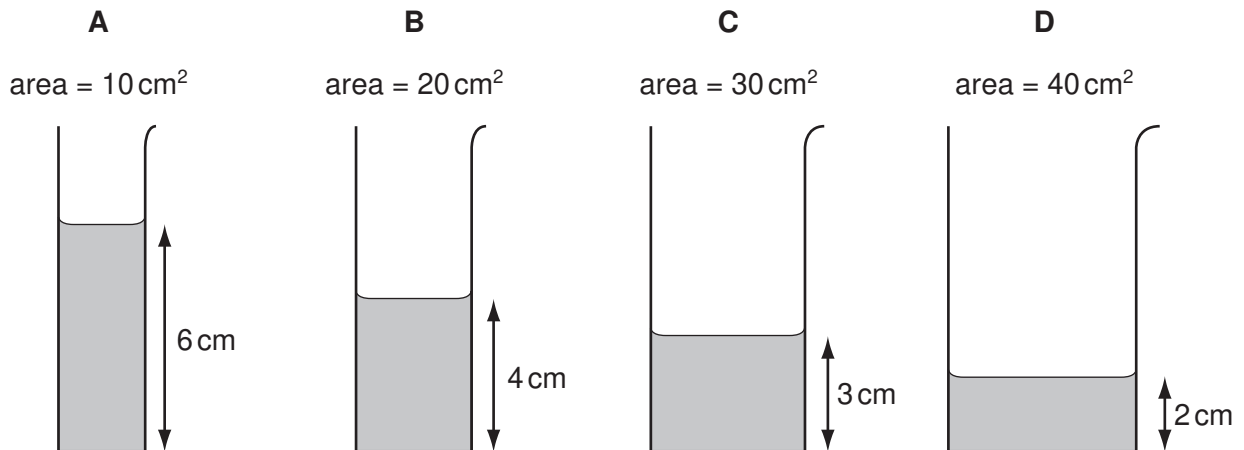

- 2 Four students try to explain what is meant by acceleration.

Which student makes a correct statement?

- A** It is related to the changing speed of an object.
 - B** It is the distance an object travels in one second.
 - C** It is the force acting on an object divided by the distance it travels in one second.
 - D** It is the force acting on an object when it is near to the Earth.
- 3 A tennis player hits a ball hard and 0.4 s later hears an echo from a wall.



The speed of sound in air is 330 m/s .

How far away is the player from the wall?

- A** 66 m
- B** 132 m
- C** 264 m
- D** 825 m

4 What are the correct units for force and for weight?

	force	weight
A	kg	kg
B	kg	N
C	N	kg
D	N	N

5 The table shows the weight of a 10 kg mass on each of five planets.

planet	weight of a 10 kg mass/N
Mercury	40
Venus	90
Earth	100
Mars	40
Jupiter	250

On which planets would an astronaut have a smaller weight than on Earth?

- A** Mercury, Mars and Jupiter
 - B** Mercury, Venus and Mars
 - C** Mercury, Venus and Jupiter
 - D** Venus, Mars and Jupiter
- 6 A student is trying to find the density of water and of a large, regularly-shaped solid.
- Which apparatus is needed to find the density of **both**?
- A** balance, clock, ruler
 - B** balance, measuring cylinder, ruler
 - C** balance, measuring cylinder, string
 - D** clock, ruler, string

- 7 A metal drum has a mass of 200 kg when empty and 1000 kg when filled with 1.0 m^3 of methylated spirit.

What is the density of methylated spirit?

- A 0.0050 kg/m^3
B 0.11 kg/m^3
C 800 kg/m^3
D 1000 kg/m^3
- 8 An empty glass is placed on a join between two tables as shown. The glass remains stable.

Which point is the centre of mass of the glass?

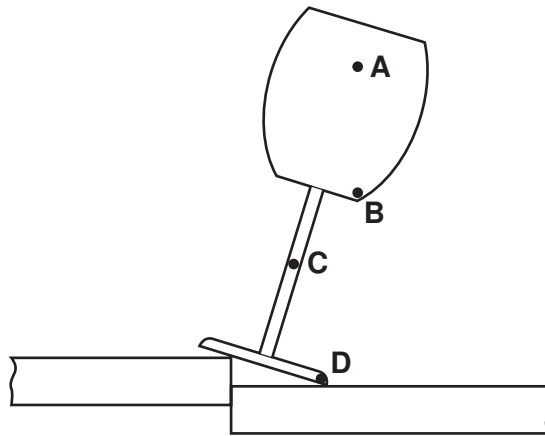

- 9 An aeroplane is in equilibrium.

The diagram shows the forces acting on the aeroplane.

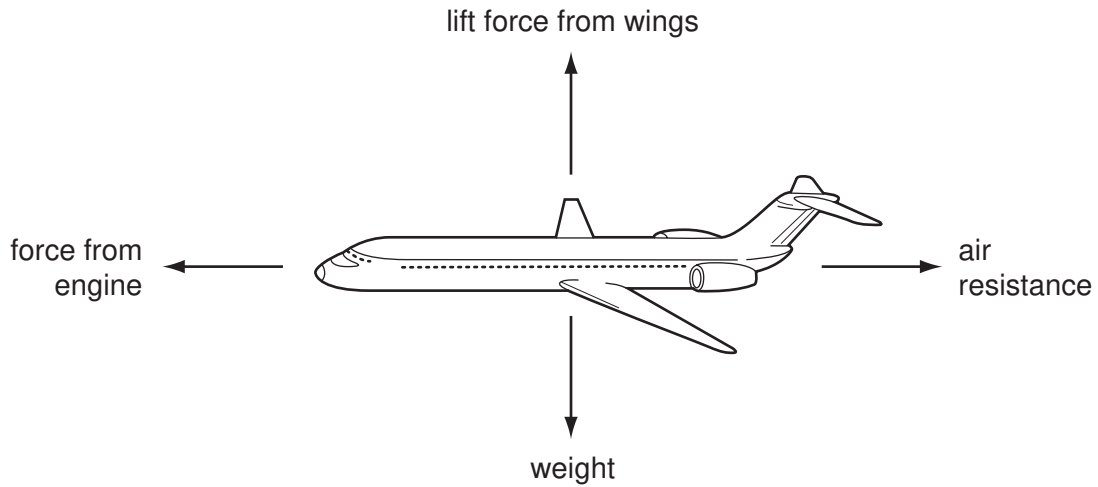

Which statement about the forces is correct?

	force from engine	lift force from wings
A	equal to air resistance	equal to weight
B	equal to air resistance	greater than weight
C	greater than air resistance	equal to weight
D	greater than air resistance	greater than weight

- 10 A student adds loads to an elastic cord. He measures the length of the cord for each load.

He then plots a graph from the results.

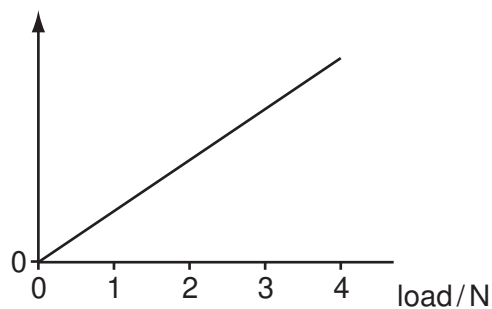

Which length is plotted on the vertical axis?

- A** measured length
- B** original length
- C** (measured length – original length)
- D** (measured length + original length)

11 A person uses chemical energy to run up some stairs.

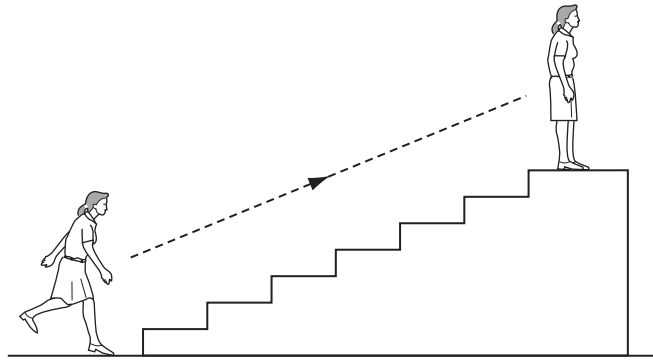

She stops at the top of the stairs.

What has the chemical energy been converted to when she is at the top of the stairs?

- A kinetic energy and gravitational energy
 - B kinetic energy and strain energy
 - C gravitational energy and heat energy
 - D strain energy and heat energy
- 12 Electrical energy may be obtained from nuclear fission.
- In what order is the energy transferred in this process?
- A nuclear fuel → generator → reactor and boiler → turbines
 - B nuclear fuel → generator → turbines → reactor and boiler
 - C nuclear fuel → reactor and boiler → generator → turbines
 - D nuclear fuel → reactor and boiler → turbines → generator

13 The diagram shows a simple mercury barometer, used to measure atmospheric pressure.

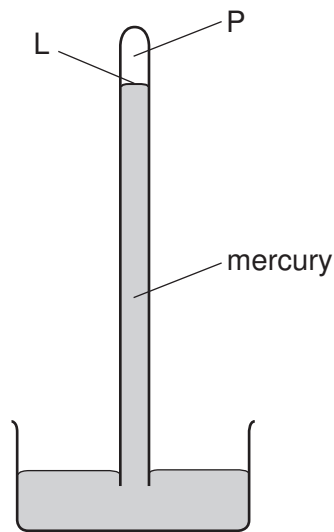

Atmospheric pressure increases.

What happens to the level L and to the pressure at P?

	level L	pressure at P
A	falls	increases
B	falls	stays the same
C	rises	increases
D	rises	stays the same

14 The gas in a container is heated but is kept at constant volume.

Why does the gas pressure increase?

- A** The molecules expand.
- B** The molecules increase in mass.
- C** The molecules move further apart.
- D** The molecules move more rapidly.

15 The table lists the melting points and the boiling points of four different substances **A**, **B**, **C** and **D**.

Which substance is a gas at 25°C?

substance	melting point/°C	boiling point/°C
A	-219	-183
B	-7	58
C	98	890
D	1083	2582

16 The diagram shows four blocks of steel. The same quantity of heat is given to each block.

Which block shows the greatest rise in temperature?

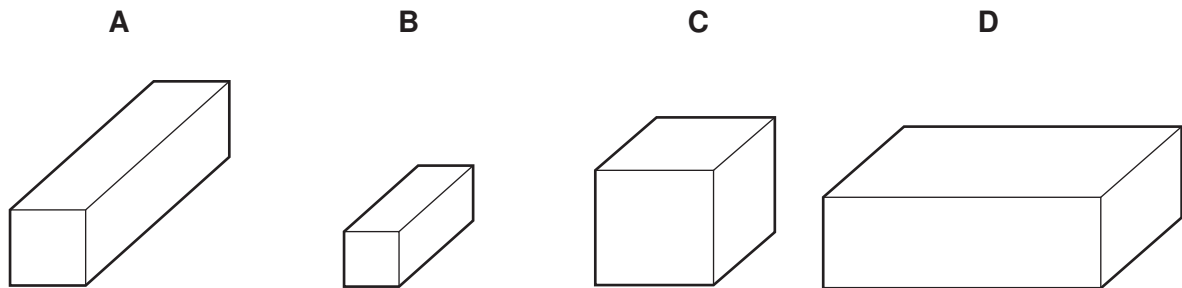

17 A wooden wheel can be strengthened by putting a tight circle of iron around it.

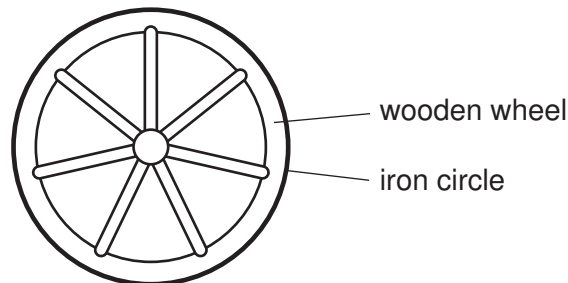

Which action would make it easier to fit the circle over the wood?

- A** cooling the iron circle
- B** heating the iron circle
- C** heating the wooden wheel
- D** heating the wooden wheel and cooling the iron circle

18 Which statement refers to convection?

- A It does not involve energy transfer.
- B It is the transfer of heat energy without the movement of particles.
- C It only occurs in liquids or gases.
- D It only occurs in solids.

19 Spoons made of different materials were placed in four cups of coffee poured from the same jug.

Which spoon will be hottest to touch at end X?

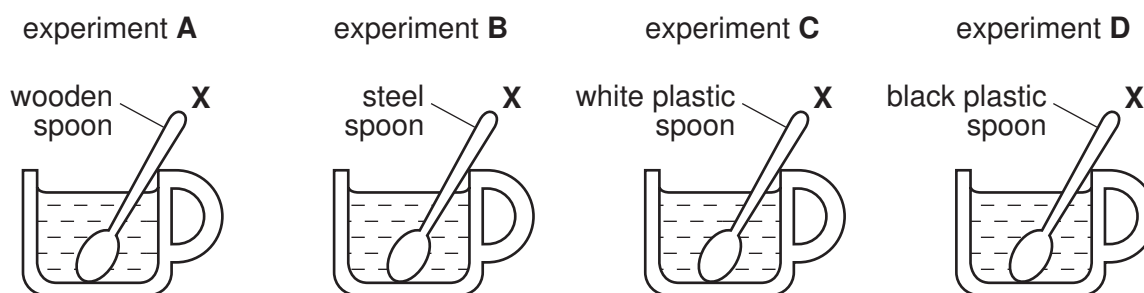

20 Which line gives an example of a longitudinal wave and describes its vibrations?

	example of a longitudinal wave	vibrations
A	light wave	at right angles to the direction the wave travels
B	light wave	in the same direction as the wave travels
C	sound wave	at right angles to the direction the wave travels
D	sound wave	in the same direction as the wave travels

21 The diagram shows a section through a series of waves on water.

Which dotted line shows the position of the still water surface after the waves have passed?

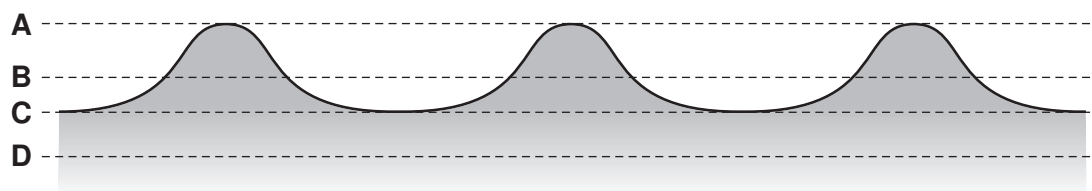

- 22 A student shines a narrow beam of white light into a prism as shown in the diagram. He sees a spectrum of colours emerging from the prism.

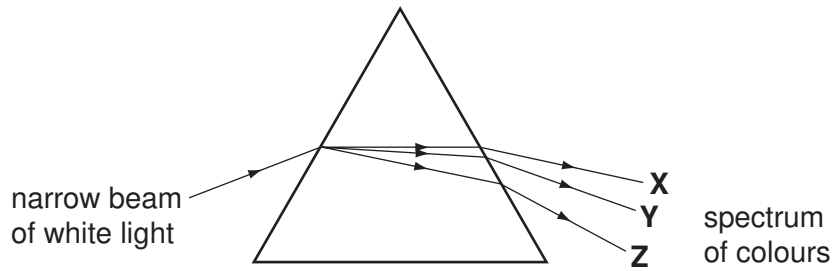

Which three colours does he see at **X**, at **Y** and at **Z**?

	X	Y	Z
A	blue	yellow	red
B	red	blue	yellow
C	red	yellow	blue
D	yellow	red	blue

- 23 An object placed in front of a plane mirror at **O** produces an image at **I**.

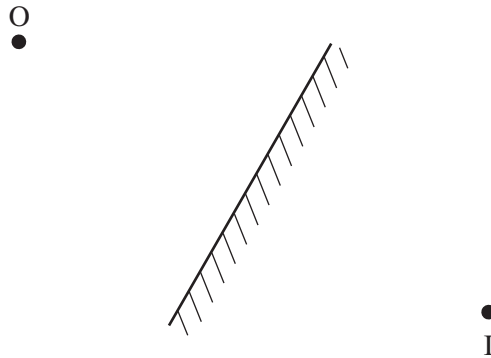

If the object moves towards the mirror in the direction shown by the arrow, in which direction does the image move?

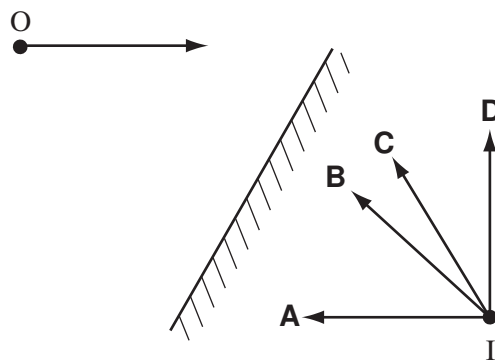

- 24 A girl stands at a distance from a large building. She claps her hands and a short time later hears an echo.

Why is an echo produced when the sound waves hit the building?

- A The sound waves are absorbed.
- B The sound waves are diffracted.
- C The sound waves are reflected.
- D The sound waves are refracted.

- 25 The graph represents a sound wave. The horizontal (x) axis represents time.

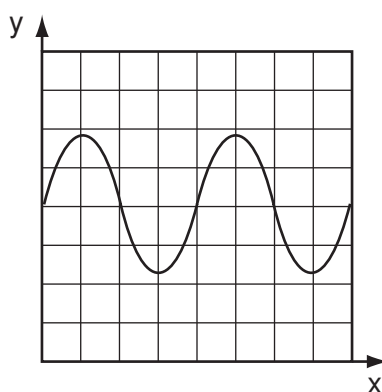

The frequency of the sound is increased.

The graphs below are shown to the same scale. Which graph represents the new sound wave?

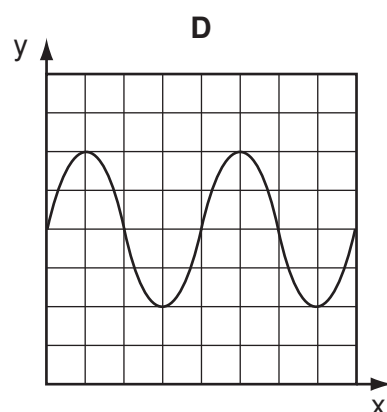
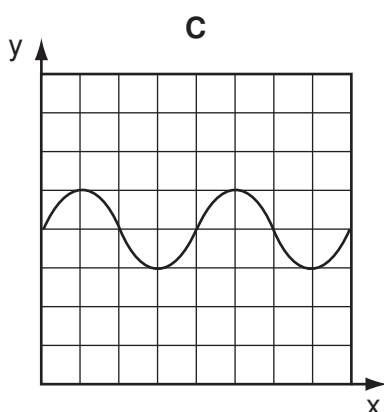
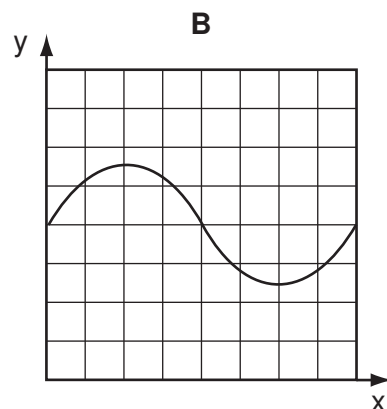
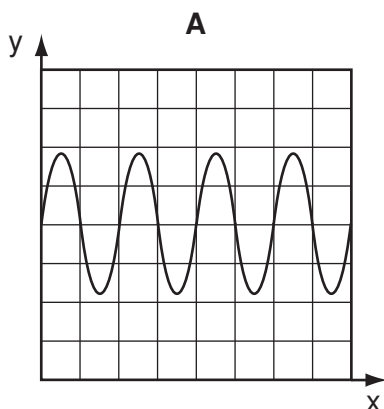

26 Which materials are suitable for making a permanent magnet and the core of an electromagnet?

	permanent magnet	core of an electromagnet
A	iron	iron
B	iron	steel
C	steel	iron
D	steel	steel

27 Three charged balls, P, Q and R, are suspended by insulated threads. Ball P is negatively charged.

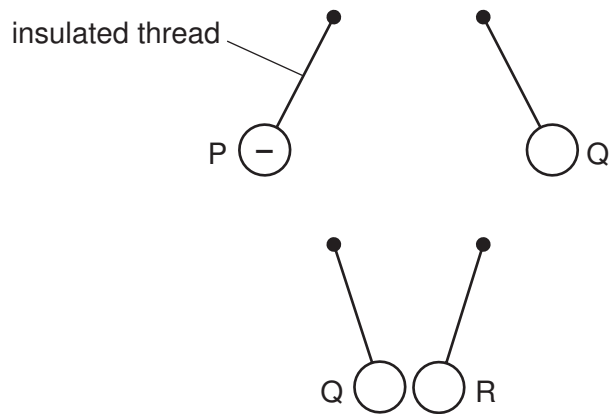

What are the charges on Q and on R?

	Q	R
A	positive	positive
B	positive	negative
C	negative	positive
D	negative	negative

28 The circuit shows a current I in a resistor of resistance R .

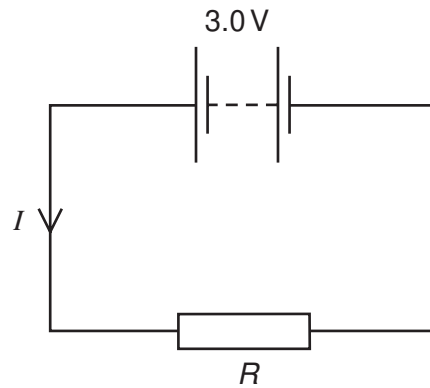

Which line gives possible values of I and of R ?

	I/A	R/Ω
A	1.5	1.5
B	1.5	2.0
C	6.0	2.0
D	4.0	12.0

29 The circuit shown in the diagram contains an unknown component X, hidden in a box.

The voltage-current graph for X is as shown.

variable voltage supply

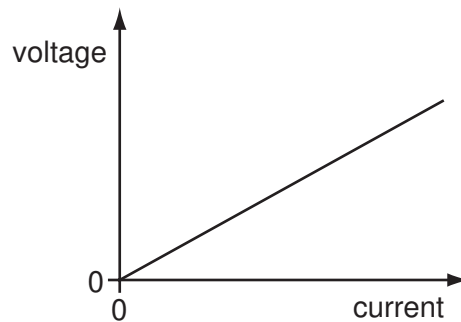
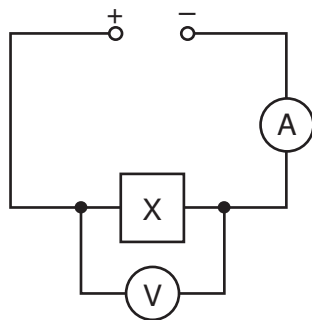

What is the component X?

- A** a capacitor
- B** a closed switch
- C** a metallic resistor
- D** an open switch

30 Four lamps are connected in a circuit as shown in the diagram.

Each lamp is designed to operate at 12V.

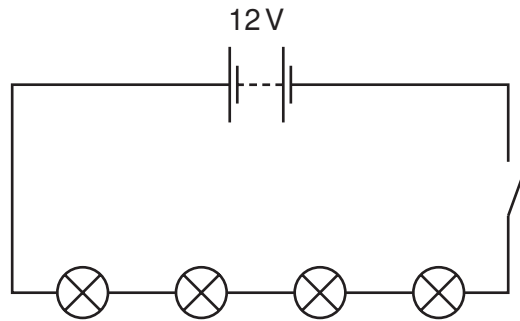

The circuit is now switched on.

Which statement is correct?

- A Each lamp can be switched off independently.
- B If one lamp breaks all the others will stay alight.
- C The current is the same in all the lamps.
- D The lamps will all light at normal brightness.

31 The diagram shows a battery connected to three identical resistors. Four ammeters **A**, **B**, **C** and **D** are connected in the circuit.

Which ammeter shows the smallest reading?

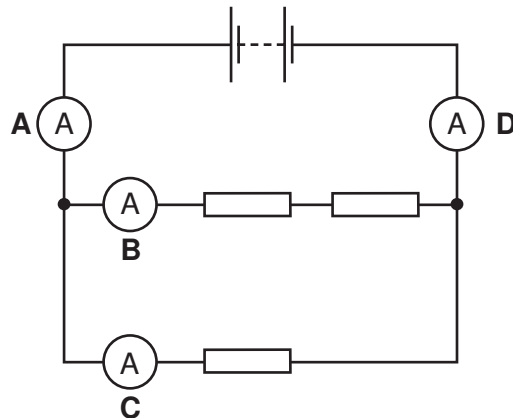

32 In the circuit shown, the switch is closed for a long time, then opened.

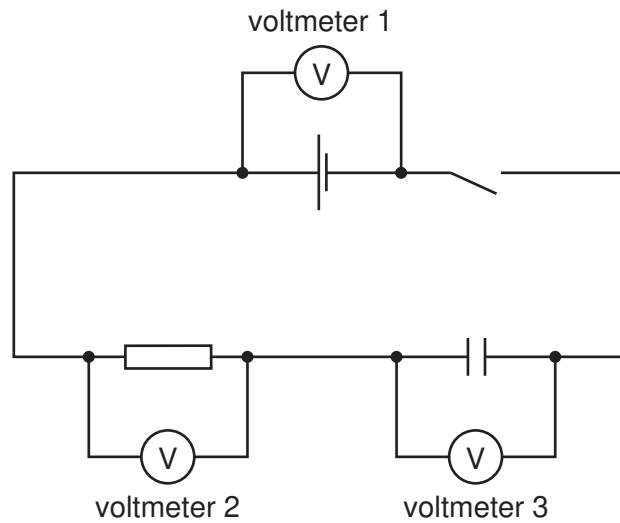

Immediately after the switch is opened, which voltmeters will read zero?

- A voltmeter 1 only
 - B voltmeter 2 only
 - C voltmeter 3 only
 - D voltmeter 1, voltmeter 2 and voltmeter 3
- 33 A householder asks an electrician to install a mains electrical socket in her bathroom so that she may use a hairdryer there. The electrician refuses to do this because it would be dangerous.

Why would installing the socket be dangerous?

- A The current drawn by the hairdryer would cause overheating in the cables.
 - B The handling of electrical equipment in damp conditions could cause an electric shock.
 - C The hot air produced by the hairdryer would cause the fuse to melt.
 - D The temperature in the bathroom would damage the insulation.
- 34 A mains electrical circuit uses insulated copper cable and the cable overheats.
- To prevent the cable overheating, how should the cable be changed, and why?
- A Use thicker copper cable which has less resistance.
 - B Use thicker insulation which stops the heat escaping.
 - C Use thinner copper cable which has more resistance.
 - D Use thinner insulation which allows less heat to escape.

35 How is electricity transmitted over large distances and why is it transmitted in this way?

	how	why
A	at high voltage	for safety
B	at high voltage	to reduce energy loss
C	at low voltage	for safety
D	at low voltage	to reduce energy loss

36 Which parts of an a.c. generator slide past each other when the generator is working?

- A** brushes and coil
- B** coil and magnets
- C** magnets and slip rings
- D** slip rings and brushes

37 The diagram shows a cathode-ray tube.

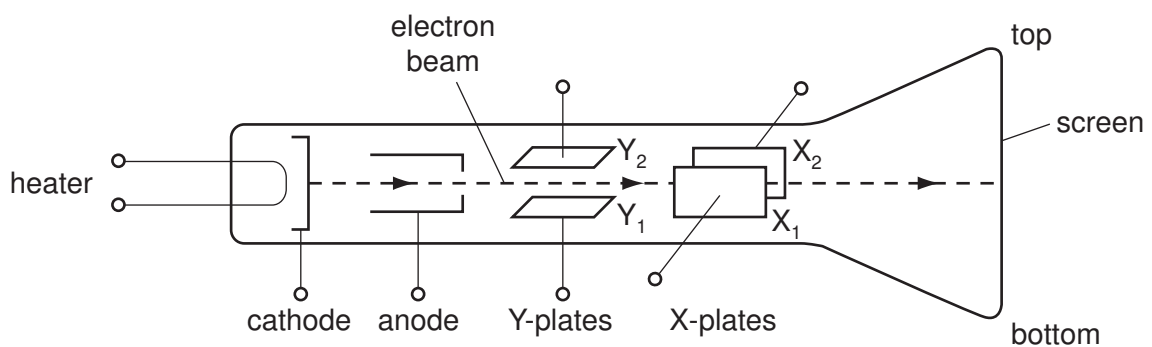

What must be done to deflect the electron beam upwards?

- A** make X₁ more positive than X₂
- B** make X₂ more positive than X₁
- C** make Y₁ more positive than Y₂
- D** make Y₂ more positive than Y₁

38 A sheet of paper is placed between a radioactive source and a detector.

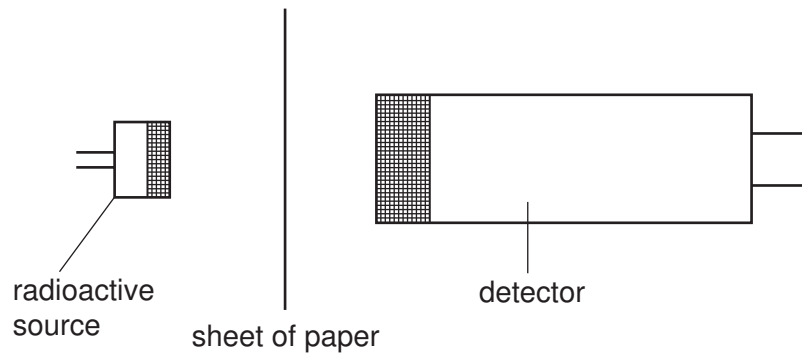

Which types of radiation can pass through the paper?

- A α -particles and β -particles only
 - B α -particles and γ -rays only
 - C β -particles and γ -rays only
 - D α -particles, β -particles and γ -rays
- 39 A sample of radioactive isotope is decaying.
- The nuclei of which atoms will decay first?
- A impossible to know, because radioactive decay is random
 - B impossible to know, unless the age of the material is known
 - C atoms near the centre, because they are surrounded by more atoms
 - D atoms near the surface, because the radiation can escape more easily

40 An atom of the element lithium has a nucleon number of 7 and a proton number of 3.

Which diagram represents a neutral atom of lithium?

A

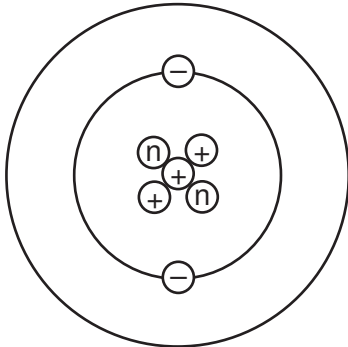

B

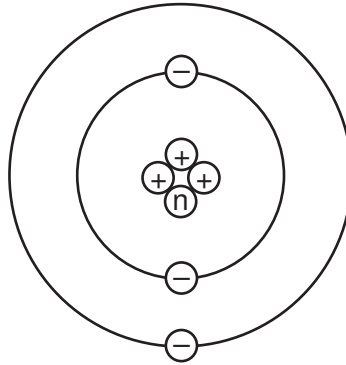

C

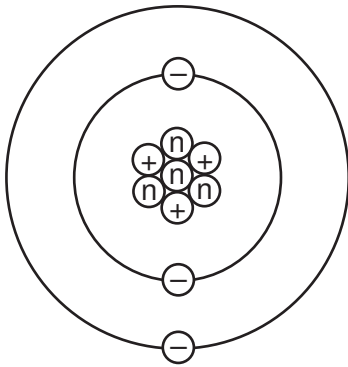

D

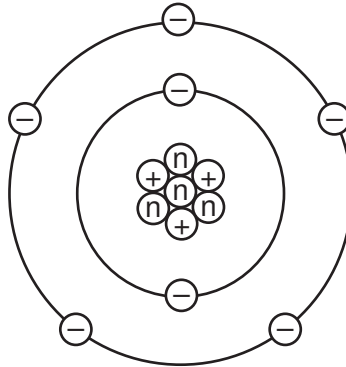

key

\textcircled{n} = a neutron

$\textcircled{+}$ = a proton

$\textcircled{-}$ = an electron

(not to scale)

BLANK PAGE

BLANK PAGE

Permission to reproduce items where third-party owned material protected by copyright is included has been sought and cleared where possible. Every reasonable effort has been made by the publisher (UCLES) to trace copyright holders, but if any items requiring clearance have unwittingly been included, the publisher will be pleased to make amends at the earliest possible opportunity.

University of Cambridge International Examinations is part of the Cambridge Assessment Group. Cambridge Assessment is the brand name of University of Cambridge Local Examinations Syndicate (UCLES), which is itself a department of the University of Cambridge.