



UNIVERSITY OF CAMBRIDGE INTERNATIONAL EXAMINATIONS
International General Certificate of Secondary Education

CANDIDATE
NAME

CENTRE
NUMBER

--	--	--	--	--

CANDIDATE
NUMBER

--	--	--	--



PHYSICS

0625/52

Paper 5 Practical Test

October/November 2010

1 hour 15 minutes

Candidates answer on the Question Paper

Additional Materials: As listed in the Confidential Instructions

READ THESE INSTRUCTIONS FIRST

Write your Centre number, candidate number and name in the spaces at the top of the page.
Write in dark blue or black pen.
You may use a pencil for any diagrams, graphs or rough working.
Do not use staples, paper clips, highlighters, glue or correction fluid.
DO NOT WRITE IN ANY BARCODES.

Answer **all** questions.

At the end of the examination, fasten all your work securely together.
The number of marks is given in brackets [] at the end of each question or part question.

For Examiner's Use	
1	
2	
3	
4	
Total	

This document consists of **9** printed pages and **3** blank pages.



- 1 In this experiment, you are to determine the density of the material of a metre rule.

Carry out the following instructions referring to Fig. 1.1.

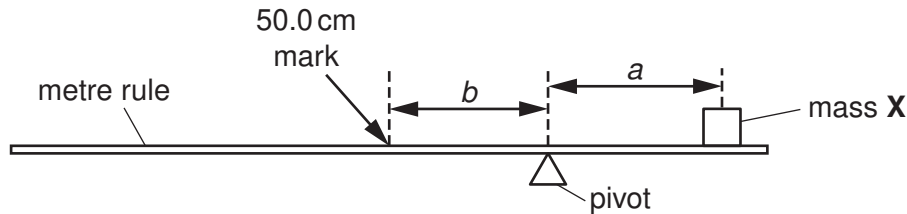

Fig. 1.1

You are provided with a 100 g mass, labelled X.

- (a) Place the mass X on the rule and adjust its position so that the rule is as near as possible to being balanced with the 50.0 cm mark to the left of the pivot as shown in Fig.1.1.

- (i) Measure the distance a from the centre of the mass X to the pivot.

$a = \dots\dots\dots$ cm

- (ii) Measure the distance b from the pivot to the 50.0 cm mark on the rule.

$b = \dots\dots\dots$ cm

- (iii) Calculate the mass m of the metre rule using the equation

$$m = \frac{ka}{b} \text{ where } k = 100 \text{ g.}$$

$m = \dots\dots\dots$

[3]

- (b) (i) Take measurements to determine the average width w of the metre rule.

$w = \dots\dots\dots$ cm

- (ii) Take measurements to determine the average thickness t of the metre rule.

$t = \dots\dots\dots$ cm

- (iii) Calculate the volume V of the metre rule using the equation $V = lwt$ where l is the length of the metre rule (100.0 cm).

For
Examiner's
Use

$V =$

- (iv) Calculate the density ρ of the metre rule using the equation $\rho = \frac{m}{V}$.

$\rho =$ [6]

- (c) State the assumption that you have made about the position of the centre of mass of the metre rule.

.....
..... [1]

[Total: 10]

- 2 In this experiment you will investigate the rate of cooling of water under different conditions.

Carry out the following instructions referring to Fig. 2.1. You are provided with a supply of hot water.

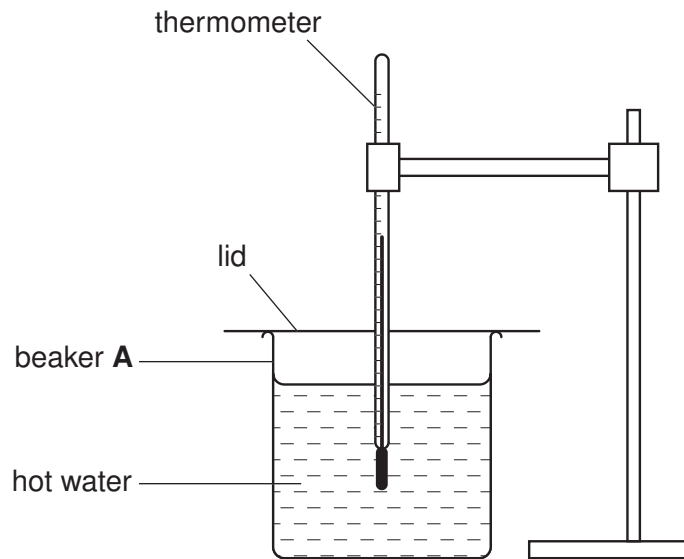

Fig. 2.1

- (a) Record the room temperature θ_r .

$$\theta_r = \dots\dots\dots [1]$$

- (b) (i) Pour approximately 75 cm^3 of hot water into the beaker labelled **A**. Place the lid on the beaker and place the thermometer through the hole in the lid and into the water as shown in Fig. 2.1.
- (ii) When the temperature shown on the thermometer stops rising record in Table 2.1 the temperature θ at time $t = 0 \text{ s}$ and immediately start the stopclock.
- (iii) Record in the table the temperature of the water at 30 s intervals from $t = 30 \text{ s}$ until you have a total of seven values up to time $t = 180 \text{ s}$. [2]

- (c) (i) Empty the water from beaker **A**. Place beaker **A** into the larger beaker labelled **B**.
 (ii) Repeat the steps (b)(i), (ii) and (iii), recording the readings in Table 2.2. [2]

For
Examiner's
Use

Table 2.1

$t/$	$\theta/$

Table 2.2

$t/$	$\theta/$

- (d) Complete the column headings in both tables. [1]
 (e) State whether the rate of cooling of the water is significantly faster or slower or about the same under the conditions used in part (c) (Table 2.2) compared with the conditions in part (b) (Table 2.1). Justify your answer by reference to your readings.

statement

justification

.....[2]

- (f) If this experiment were to be repeated in order to check the results it would be important to control the conditions. Suggest two such conditions that should be controlled.

1.

.....

2.

.....[2]

[Total: 10]

- 3 In this experiment, you will investigate the potential difference across a resistor.

Carry out the following instructions referring to Fig. 3.1.

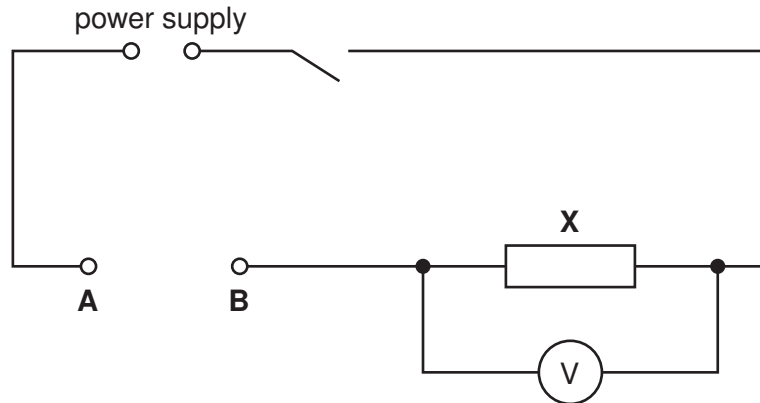

Fig. 3.1

The circuit provided contains a resistor **X**. There is a gap in the circuit between points **A** and **B** to be used for adding extra resistors, of resistance R , to the circuit.

- (a) Connect points **A** and **B** together. Switch on. Measure the potential difference V_0 across resistor **X**.

$$V_0 = \dots\dots\dots[1]$$

Switch off and separate points **A** and **B**.

- (b) (i) Do not change the position of the voltmeter in the circuit. Connect the 3.3Ω resistor between points **A** and **B**. Switch on and record in Table 3.1 the potential difference V across the resistor **X**. Switch off and disconnect the 3.3Ω resistor from between **A** and **B**.
- (ii) Repeat the steps in part (b)(i) with each of the other two extra resistors.
- (iii) Repeat the steps in part (b)(i) with the 3.3Ω and 6.8Ω resistors connected in series with each other.
- (iv) Complete the column headings in the table.

Table 3.1

$R/$	$V/$
3.3	
4.7	
6.8	
10.1	

[3]

(c) Plot the graph of V/V (y -axis) against R/Ω (x -axis). Begin both axes at 0.

For
Examiner's
Use

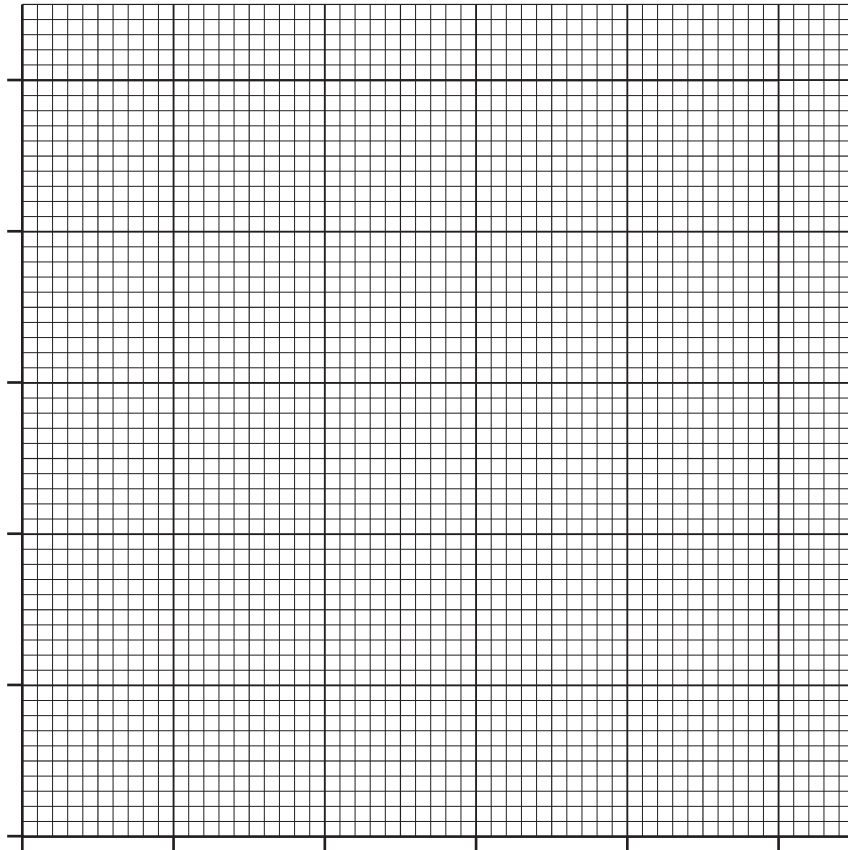

[4]

(d) Use the graph to estimate the value of potential difference V when $R = 0 \Omega$. Show clearly on the graph how you obtained your result.

$V = \dots\dots\dots$ [2]

[Total: 10]

- 4 In this experiment you will investigate shadows formed on a screen.

Carry out the following instructions referring to Fig. 4.1.

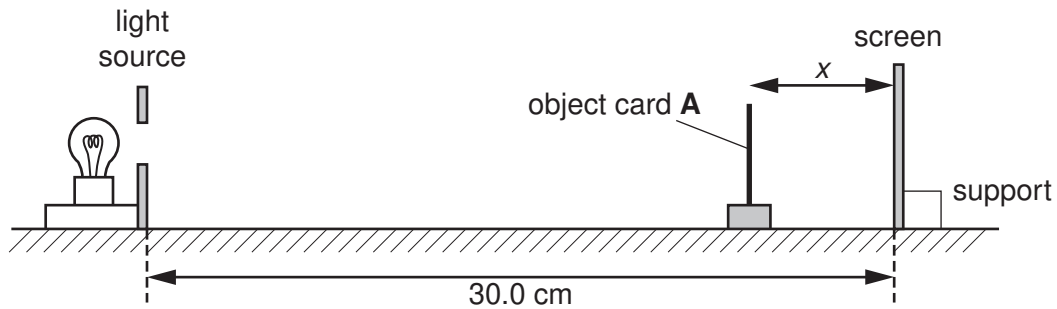

Fig. 4.1

You are provided with a lamp behind a piece of card. The card has a circular hole which in this experiment is referred to as the light source.

- (a) Place the screen so that its centre is 30.0 cm from the light source.
 (b) Measure the diameter d of the circular object card labelled **A**.

$$d = \dots\dots\dots \text{ cm [1]}$$

- (c) Place the object card **A** at a distance $x = 2.0$ cm from the screen. Switch on the light source. Measure and record in Table 4.1 the diameter s of the shadow of the object card formed on the screen. The screen has a sheet of graph paper taped to it. You may mark the graph paper to assist in measuring the diameter of the shadow.
 (d) Repeat the steps in (c) using values of $x = 4.0$ cm, 6.0 cm, 8.0 cm and 10.0 cm.

Table 4.1

x/cm	s/cm	s^2/cm^2

[5]

- (e) Calculate the values of s^2 and enter them in the table.

[1]

- (f) A student suggests that the value of s^2 when $x = 10.0\text{cm}$ should be twice the value of s^2 when $x = 2.0\text{cm}$. State whether your experimental results support this suggestion and justify your statement by reference to your results.

statement

explanation

.....[2]

- (g) State one precaution you took in order to obtain reliable measurements.

.....

.....[1]

[Total: 10]

BLANK PAGE

Permission to reproduce items where third-party owned material protected by copyright is included has been sought and cleared where possible. Every reasonable effort has been made by the publisher (UCLES) to trace copyright holders, but if any items requiring clearance have unwittingly been included, the publisher will be pleased to make amends at the earliest possible opportunity.

University of Cambridge International Examinations is part of the Cambridge Assessment Group. Cambridge Assessment is the brand name of University of Cambridge Local Examinations Syndicate (UCLES), which is itself a department of the University of Cambridge.