



UNIVERSITY OF CAMBRIDGE INTERNATIONAL EXAMINATIONS  
International General Certificate of Secondary Education

www.XtremePapers.com

**PHYSICS**

**0625/52**

Paper 5 Practical Test

**October/November 2011**

**CONFIDENTIAL INSTRUCTIONS**

**Great care should be taken to ensure that any confidential information given does not reach the candidates either directly or indirectly.**



If you have any problems or queries regarding these Instructions, please contact CIE  
by e-mail: [International@cie.org.uk](mailto:International@cie.org.uk),  
by phone: +44 1223 553554,  
by fax: +44 1223 553558,  
stating the Centre number, the nature of the query and the syllabus number quoted above.

This document consists of **8** printed pages.



### Instructions for preparing apparatus

The Supervisor is **not** allowed to consult the Question Paper before the examination. This teacher should, as part of the preparation of the examination requirements, test the apparatus in order to ensure that it is satisfactory.

The Supervisor is asked to give (and attach to the Report form printed on pages 11 and 12) a *brief* description of the apparatus supplied, mentioning any points that are likely to be of importance to the Examiner in marking the answers. The Supervisor should also report any assistance given to candidates. All reports should be signed by the Supervisor and by the person responsible for preparing the apparatus.

In addition to the usual equipment of a physics laboratory, each candidate will require the apparatus specified in these Instructions. If a candidate breaks any of the apparatus, or loses any of the material supplied, the matter should be rectified and a note made in the Report.

### Number of sets of apparatus

As a *minimum*, the number of sets of apparatus provided should be  $N/4$ , where  $N$  is the number of candidates (per session). A few spare sets should, preferably, be available to avoid any candidate being delayed when moving to another question.

Centres may find it more convenient and easier to administer if  $N/3$  sets (plus one or two 'spares') of apparatus are provided.

The order in which a given candidate attempts the four questions is immaterial.

### Assistance to Candidates

The purpose of the Practical Physics test is to find out whether the candidates can carry out simple practical work themselves. The Examiners are aware that candidates may sometimes be unable to show their practical ability through failure to understand some point in the theory of the experiment. If an Examiner were present in the laboratory, he/she would be willing to give a hint to enable such a candidate to get on with an experiment. In order to overcome this difficulty, the Supervisor is asked to co-operate with the Examiners to the extent of being ready to give (or allow the Physics teacher to give) a hint to a candidate who is unable to proceed.

The following regulations must be strictly adhered to.

- (i) No hint may be announced to the candidates as a whole.
- (ii) A candidate who is unable to proceed and requires assistance must come up to the Supervisor and state the difficulty. Candidates should be told that the Examiners will be informed of any assistance given in this way.
- (iii) A report must be made of any assistance given to the candidate, with the name and candidate number of the candidate.

It is suggested that the following announcement be made to the candidates.

'The Examiners do not want you to waste time through inability to get on with an experiment. Any candidate, therefore, who is unable to get on with the experiment after spending five minutes at it may come to me and ask for help. I shall report to the Examiners any help given in this way, and some marks may be lost for the help given. You may ask me for additional apparatus which you think would improve the accuracy of your experiments, and you should say, on your script, how you use any such apparatus supplied.'

**Question 1****Items to be supplied by the Centre (per set of apparatus unless otherwise specified)**

- (i) Metre rule with a mm scale (see note 1).
- (ii) Triangular block to act as a pivot for the metre rule. This block is to stand on the bench.
- (iii) A lump of modelling clay (e.g. Plasticine) of mass approximately 100 g (see note 2).
- (iv) 30 cm or 50 cm rule with a mm scale.
- (v) A card showing the mass  $M$  of the metre rule in grams. The mass is to be given to the nearest whole number (for example, ' $M = 106$  g').

**Notes**

1. The metre rule should approximately balance on the pivot when the 50.0 cm mark is over the pivot.
2. The modelling clay (e.g. Plasticine) should be preworked so that it is easy for the candidate to mould. It should not be of a type that will harden over the time of the examination.

**Action at changeover**

Remould the modelling clay into a single lump.

**Question 2****Items to be supplied by the Centre (per set of apparatus, unless otherwise specified)**

- (i) Thermometer:  $-10^{\circ}\text{C}$  to  $110^{\circ}\text{C}$ , graduated in  $1^{\circ}\text{C}$  intervals.
- (ii)  $250\text{ cm}^3$  beaker, labelled **A**.
- (iii)  $100\text{ cm}^3$  measuring cylinder.
- (iv) Supply of hot water (see notes 1, 3 and 5). Each candidate will require at least  $100\text{ cm}^3$ .
- (v) Supply of water at room temperature (see note 2). Each candidate will require at least  $60\text{ cm}^3$ .
- (vi) Clamp, boss and stand (see note 4).
- (vii) Supply of paper towels to mop up any spillages of water.
- (viii) Stirrer (a teaspoon is suitable).

**Notes**

1. The hot water is to be supplied for each candidate by the Supervisor. The water should be maintained at a temperature as hot as is reasonably possible.
2. The water at room temperature is to be supplied for each candidate by the Supervisor.
3. Candidates should be warned of the dangers of burns or scalds when using very hot water.
4. The clamp, boss and stand should be set up with the thermometer held in the clamp. The candidates must be able easily and safely to read temperatures up to  $100^{\circ}\text{C}$  and to move the thermometer in and out of the water without the danger of the beaker tipping.
5. The candidates must be provided with the means easily and safely to pour hot water into the measuring cylinder.

**Action at changeover**

Empty the beaker labelled **A**. Check the supplies of hot water and water at room temperature.

### Question 3

#### Items to be supplied by the Centre (per set of apparatus unless otherwise specified)

- (i) Power source of approximately 1.5 – 2V. Where candidates are supplied with a power source with a variable output voltage, the voltage setting should be set by the Supervisor and fixed (e.g. taped).
- (ii) Voltmeter capable of measuring the supply p.d. with a minimum resolution of 0.1 V.
- (iii) Ammeter capable of measuring current with a minimum resolution of 0.05 A.
- (iv) Three resistors of nominal value  $4.7\Omega$  with a power rating of at least 2W (see notes 2 and 3).
- (v) Switch (this can be an integral part of the power supply).
- (vi) Sufficient connecting leads to set up the circuit shown in Fig. 3.1 plus two additional leads.

#### Notes

1. The circuit is to be set up for the candidates as shown in Fig. 3.1 with the additional leads and the voltmeter within easy reach.
2. The resistors must all have suitable terminals so that the candidates can easily and quickly connect the voltmeter.
3. The resistors must be labelled  $R_1$ ,  $R_2$  and  $R_3$  and positioned in the circuit as shown in Fig. 3.1.

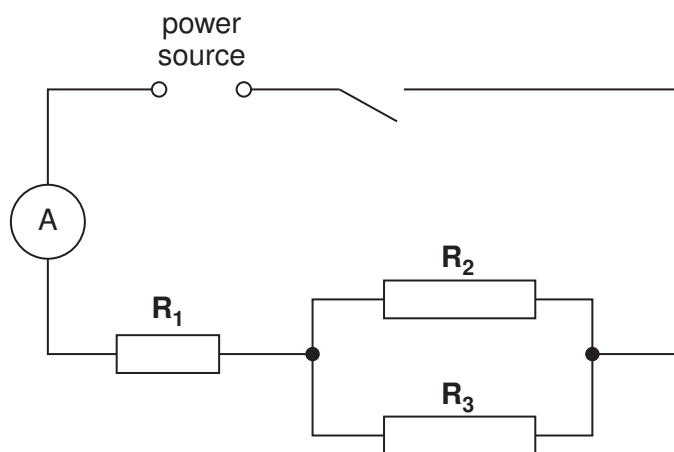

Fig. 3.1

#### Action at changeover

Check that the circuit is as shown in Fig. 3.1.

**Question 4****Items to be supplied by the Centre (per set of apparatus, unless otherwise specified)**

- (i) Sheet of plain A4 size paper with a hole in one corner (one per candidate) (see note 3).
- (ii) Plane mirror with a holder (see notes 1 and 2).
- (iii) Three optics pins.
- (iv) Pin board (e.g. a cork mat), A4 size or larger.
- (v) Protractor.
- (vi) 50 cm or 30 cm rule, graduated in mm.
- (vii) String or treasury tag (to tie the plain A4 sheet of paper into the Question Paper).

**Notes**

1. The mirror should be capable of standing vertically with one edge on the sheet of plain A4 paper.
2. The mirror is to have a thin straight line drawn on the front surface at the centre as shown in Fig. 4.1. The line can be drawn with a felt-tipped pen.

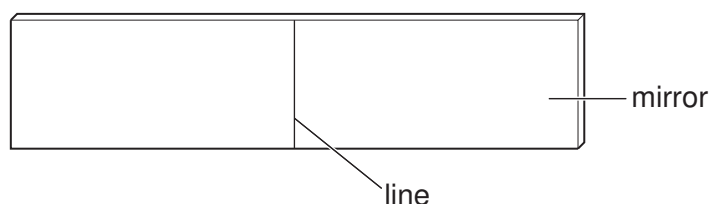
**Fig. 4.1**

3. Spare sheets of plain paper should be available.
4. Spare pins should be available.
5. Spare mirrors should be available.

**Action at changeover**

Supply a sheet of plain A4 paper. Check that the line on the mirror is still visible.

---

Permission to reproduce items where third-party owned material protected by copyright is included has been sought and cleared where possible. Every reasonable effort has been made by the publisher (UCLES) to trace copyright holders, but if any items requiring clearance have unwittingly been included, the publisher will be pleased to make amends at the earliest possible opportunity.

University of Cambridge International Examinations is part of the Cambridge Assessment Group. Cambridge Assessment is the brand name of University of Cambridge Local Examinations Syndicate (UCLES), which is itself a department of the University of Cambridge.

**This form must be completed and returned with the scripts.**

**REPORT ON PRACTICAL PHYSICS**

(IGCSE OCTOBER/NOVEMBER 2011)

*General*

The Supervisor is required to give details of any difficulties experienced by particular candidates giving their names and candidate numbers. These should include reference to:

- (a) difficulties due to faulty apparatus;
- (b) accidents to apparatus or materials;
- (c) any other information that is likely to assist the Examiner, especially if this cannot be discovered in the scripts;
- (d) any help given to a candidate.

*Information required*

A plan of workbenches, giving details by candidate number of the places occupied by the candidates for each experiment for each session, must be enclosed with the scripts.



*Information required (cont.)*

A list by name and candidate number of candidates requiring help, with details of the help provided.

CENTRE NO. ....

NAME OF CENTRE .....

*Declaration (to be signed by the Supervisor and the person responsible for preparing the apparatus)*

The preparation of the practical examination has been carried out so as to maintain fully the security of the examination.

SIGNED .....  
Supervisor

SIGNED .....  
Person responsible for preparing the apparatus

