



UNIVERSITY OF CAMBRIDGE INTERNATIONAL EXAMINATIONS
International General Certificate of Secondary Education

CANDIDATE
NAME

CENTRE
NUMBER

--	--	--	--	--

CANDIDATE
NUMBER

--	--	--	--



PHYSICS

0625/51

Paper 5 Practical Test

May/June 2012

1 hour 15 minutes

Candidates answer on the Question Paper.

Additional Materials: As listed in the Confidential Instructions.

READ THESE INSTRUCTIONS FIRST

Write your Centre number, candidate number and name in the spaces at the top of the page.

Write in dark blue or black pen.

You may use a pencil for any diagrams, graphs or rough working.

Do not use staples, paper clips, highlighters, glue or correction fluid.

DO **NOT** WRITE IN ANY BARCODES.

Answer **all** questions.

At the end of the examination, fasten all your work securely together.

The number of marks is given in brackets [] at the end of each question or part question.

For Examiner's Use	
1	
2	
3	
4	
Total	

This document consists of **9** printed pages and **3** blank pages.



- 1 The aim of this experiment is to determine the internal volume of a test-tube using two displacement methods.

Carry out the following instructions referring to Figs. 1.1, 1.2 and 1.3. You are supplied with a beaker of water.

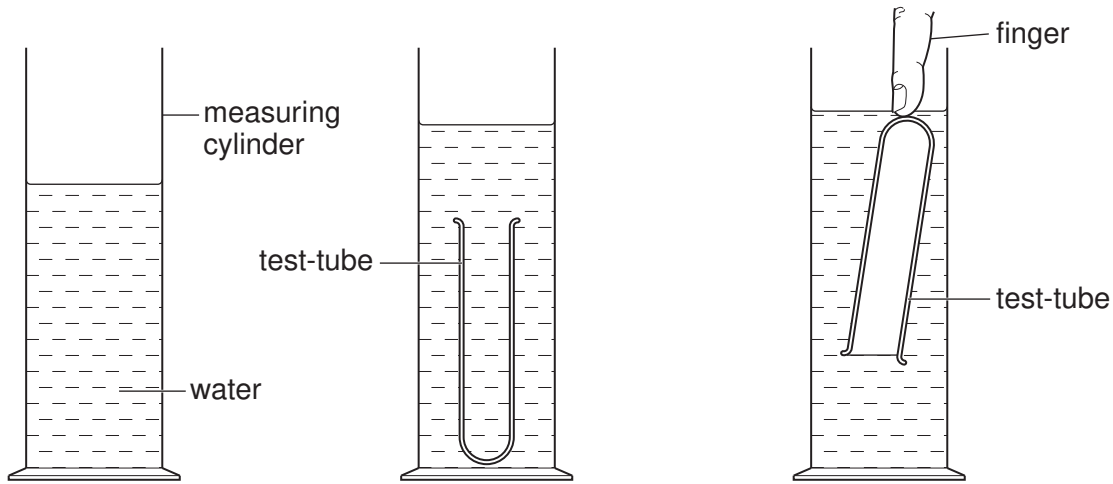

Fig. 1.1

Fig. 1.2

Fig. 1.3

- (a) (i) Pour approximately 80cm^3 of water from the beaker into the measuring cylinder. Record the volume V_1 of water.

$$V_1 = \dots\dots\dots$$

- (ii) Lower the test-tube, closed end first, into the water in the measuring cylinder and push it down until it is filled with water, as shown in Fig. 1.2. Record the new water level V_2 .

$$V_2 = \dots\dots\dots$$

- (iii) Calculate the volume V_G of the glass of the test-tube using the equation $V_G = (V_2 - V_1)$.

$$V_G = \dots\dots\dots [3]$$

- (b) Remove the test-tube from the measuring cylinder and pour the water from the tube and the measuring cylinder into the beaker.

- (i) Pour approximately 70cm^3 of water from the beaker into the measuring cylinder. Record the volume V_3 of water.

$$V_3 = \dots\dots\dots$$

- (ii) Gently put the test-tube, open end first, into the water in the measuring cylinder and carefully push it down with your finger or pencil until it is just covered with water, as shown in Fig. 1.3. Record the new water level V_4 .

$$V_4 = \dots\dots\dots$$

(iii) Calculate the increase in water level ($V_4 - V_3$).

$(V_4 - V_3) = \dots\dots\dots$

(iv) Calculate the volume V_A of air in the test-tube using the equation $V_A = (V_4 - V_3) - V_G$.

$V_A = \dots\dots\dots$
[3]

(c) Remove the test-tube from the measuring cylinder and pour the water from the measuring cylinder into the beaker. Fill the test-tube to the top with water from the beaker. Pour the water from the test-tube into the measuring cylinder. Record the volume V_W of water from the tube.

$V_W = \dots\dots\dots$
[1]

(d) The aim of this experiment is to determine the internal volume of the test-tube by two methods. The two values are V_A (obtained from parts (a) and (b)) and V_W (obtained from part (c)). The values obtained from your readings may not be the same.

Assuming that the experiments have been carried out correctly and carefully, and that the measuring cylinder scale is accurate, suggest two reasons why the value V_A may be inaccurate and two reasons why the value V_W may be inaccurate.

V_A :

reason 1
.....

reason 2
.....

V_W :

reason 1
.....

reason 2
.....

[3]

[Total: 10]

2 In this experiment, you will investigate the heating of a thermometer bulb.

Carry out the following instructions, referring to Figs. 2.1 and 2.2.

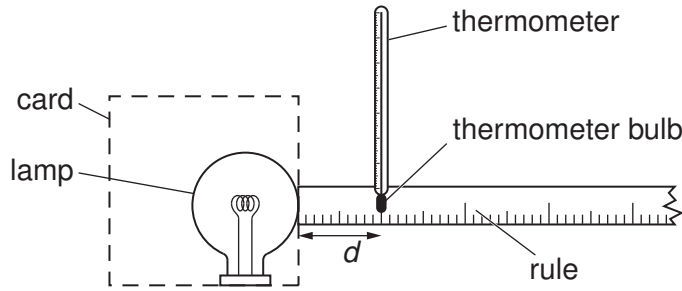

Fig. 2.1

You are provided with a lamp and a rule. Do not move the lamp or the rule. During the experiment, you will read temperature values from the thermometer. You should use the card provided to shield your eyes from the direct rays of the lamp.

(a) Record the value of room temperature θ_R shown on the thermometer.

$\theta_R = \dots\dots\dots$ [1]

(b) Switch on the lamp. Leave the lamp switched on until you have completed all the readings.

- (i) Place the thermometer so that its bulb is a horizontal distance $d = 100$ mm from the surface of the lamp, as shown in Fig. 2.1. Record in Table 2.1 the distance d between the thermometer bulb and the surface of the lamp. Also record the temperature θ shown on the thermometer.
- (ii) Move the thermometer so that its bulb is a distance $d = 80$ mm from the surface of the lamp.

In the table, record the distance d and the temperature θ .

Table 2.1

$d/$	$\theta/$

(iii) Repeat the steps described in (b)(ii), but using values of d of 60 mm, 40 mm, 20 mm and 10 mm.

(iv) Complete the column headings in the table.

[4]

- (c) Move the thermometer away from the lamp and wait for about a minute for the thermometer to cool.

For
Examiner's
Use

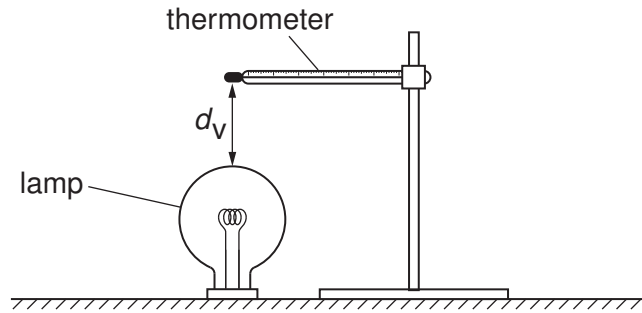

Fig. 2.2

- (i) Place the thermometer so that its bulb is a vertical distance $d_V = 100\text{ mm}$ from the top surface of the lamp, as shown in Fig. 2.2. Use the 100 mm rod provided to obtain the correct distance. Record the temperature θ_V shown on the thermometer.

$\theta_V = \dots\dots\dots$ [1]

- (ii) Calculate the difference between θ_V and the thermometer reading θ_H at a horizontal distance of 100 mm from the lamp. State whether θ_V is higher, lower or the same as θ_H .

temperature difference = $\dots\dots\dots$

θ_V is $\dots\dots\dots$ [1]

- (d) A student suggests that θ_V will be higher than the thermometer reading θ_H because thermal energy will travel by infra-red radiation and convection to the thermometer bulb above the lamp but by infra-red radiation only when the bulb is to one side of the lamp.

If the experiment were to be repeated in order to investigate this suggestion, it would be important to control the conditions. Suggest two such conditions, relevant to this investigation, that should be controlled.

1. $\dots\dots\dots$
 2. $\dots\dots\dots$
- [2]

- (e) Briefly describe a precaution that you took in this experiment in order to obtain a reliable result.

$\dots\dots\dots$
 $\dots\dots\dots$

[1]

[Total: 10]

3 In this experiment, you will determine the resistance of a resistor in a circuit.

Carry out the following instructions referring to Fig. 3.1. The circuit is set up for you.

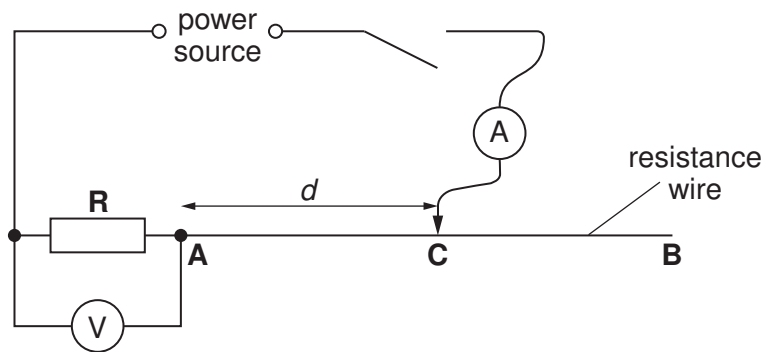

Fig. 3.1

- (a) (i) Place the sliding contact **C** on the resistance wire at a distance $d = 30.0$ cm from point **A**. Switch on. Measure and record in Table 3.1 the current I in the circuit and the p.d. V across the resistor **R**. Switch off.
- (ii) Repeat the procedure in step (i) using d values of 40.0 cm, 50.0 cm, 70.0 cm and 90.0 cm.
- (iii) Complete the column headings in the table.

Table 3.1

$d/$	$V/$	$I/$
30.0		
40.0		
50.0		
70.0		
90.0		

[2]

(b) Plot a graph of V/V (y -axis) against I/A (x -axis).

For
Examiner's
Use

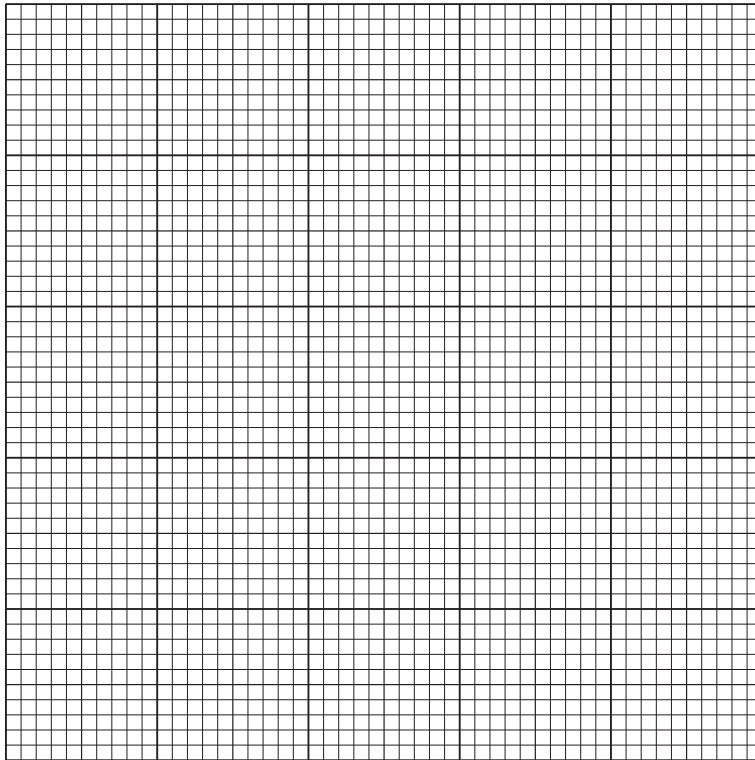

[4]

(c) Determine the gradient G of the graph. Show clearly on the graph how you obtained the necessary information.

$G = \dots\dots\dots$ [2]

(d) The gradient G of the graph is numerically equal to the resistance R of the resistor **R**.

Write a value for the resistance R to a suitable number of significant figures for this experiment.

$R = \dots\dots\dots$ [2]

[Total: 10]

- 4 In this experiment, you will determine the focal length of a lens.

Carry out the following instructions referring to Fig. 4.1.

For
Examiner's
Use

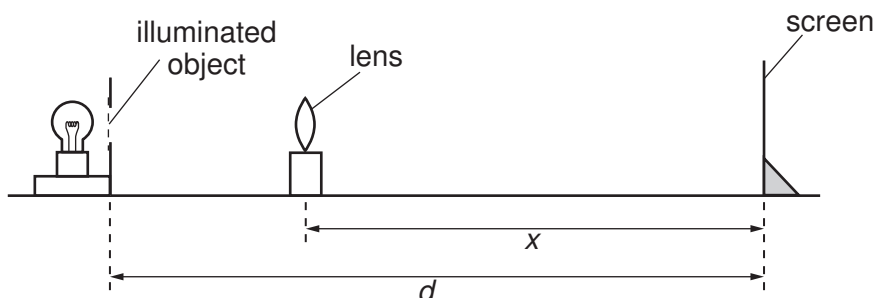

Fig. 4.1

- (a) Place the screen at a distance $d = 0.800$ m from the illuminated object.
- (b) Place the lens between the object and the screen and close to the object. Move the lens towards the screen until an **enlarged** image is formed on the screen. Adjust the position of the lens until the image is as clearly focused as possible.
- (c) Measure and record the distance x between the centre of the lens and the screen.

$$x = \dots\dots\dots [1]$$

- (d) Without moving the illuminated object or the screen, move the lens towards the screen until a clearly focused **diminished** image is formed on the screen.
- (e) Measure and record the distance y between the centre of the lens and the screen.

$$y = \dots\dots\dots [2]$$

- (f) Calculate the focal length f of the lens using the equation $f = \frac{xy}{d}$.

$$f = \dots\dots\dots [1]$$

- (g) Turn the lens through an angle of 180° so that the other side of the lens faces the screen. Repeat steps (a) to (f).

For
Examiner's
Use

$x =$

$y =$

$f =$

[3]

- (h) A student suggests that the two values of the focal length f should be the same. State whether or not your results support this suggestion. Justify your answer by reference to the results.

statement

justification

.....

[2]

- (i) Briefly describe a precaution that you took in this experiment in order to obtain a reliable result.

.....

.....

..... [1]

[Total: 10]

BLANK PAGE

Permission to reproduce items where third-party owned material protected by copyright is included has been sought and cleared where possible. Every reasonable effort has been made by the publisher (UCLES) to trace copyright holders, but if any items requiring clearance have unwittingly been included, the publisher will be pleased to make amends at the earliest possible opportunity.

University of Cambridge International Examinations is part of the Cambridge Assessment Group. Cambridge Assessment is the brand name of University of Cambridge Local Examinations Syndicate (UCLES), which is itself a department of the University of Cambridge.