



UNIVERSITY OF CAMBRIDGE INTERNATIONAL EXAMINATIONS
International General Certificate of Secondary Education

CANDIDATE
NAME

CENTRE
NUMBER

--	--	--	--	--

CANDIDATE
NUMBER

--	--	--	--



PHYSICS

0625/52

Paper 5 Practical Test

October/November 2012

1 hour 15 minutes

Candidates answer on the Question Paper

Additional Materials: As listed in the Confidential Instructions

READ THESE INSTRUCTIONS FIRST

Write your Centre number, candidate number and name in the spaces at the top of the page.

Write in dark blue or black pen.

You may use a pencil for any diagrams, graphs or rough working.

Do not use staples, paper clips, highlighters, glue or correction fluid.

DO NOT WRITE IN ANY BARCODES.

Answer **all** questions.

At the end of the examination, fasten all your work securely together.

The number of marks is given in brackets [] at the end of each question or part question.

For Examiner's Use	
1	
2	
3	
4	
Total	

This document consists of **9** printed pages and **3** blank pages.



1 In this experiment, you will investigate a pendulum.

Carry out the following instructions, referring to Fig. 1.1. The apparatus has been set up for you.

Do not adjust the length of the pendulum or the position of the clamp.

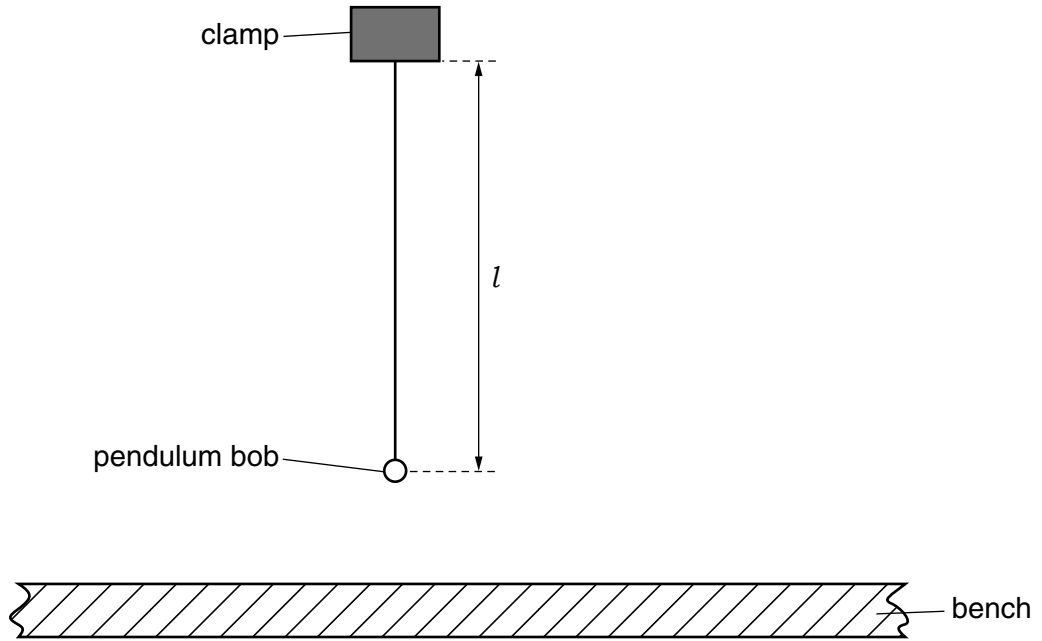

Fig. 1.1

(a) Measure and record the length l of the pendulum.

$l = \dots\dots\dots$ [1]

(b) Place the metre rule on the bench so that the 50.0cm mark is vertically below the centre of the pendulum bob. Describe how you judge that the 50.0cm mark is vertically below the centre of the pendulum bob. You may draw a diagram.

.....

.....

..... [1]

- (c) (i) Pull the pendulum bob to one side until it is vertically above the 52.0cm mark on the rule. Release the pendulum bob, then measure and record in Table 1.1 the time t taken for 10 complete swings of the pendulum. The distance d that the pendulum bob was moved is recorded in the first column of the table.
- (ii) Calculate the period T of the pendulum. The period T is the time taken for one complete swing of the pendulum.

Table 1.1

$d/$	$t/$	$T/$
2.0		
3.0		
4.0		
5.0		
6.0		

- (iii) Repeat steps (i) and (ii) using d values of 3.0cm, 4.0cm, 5.0cm and 6.0cm.
- (iv) Complete the column headings in the table.

[5]

- (d) Using the evidence in the table, describe the effect on the period T of increasing the distance d . Justify your answer by reference to your results.

description

.....

justification

.....

.....

[2]

- (e) Explain briefly why it is sensible to measure the time taken for ten swings of the pendulum rather than one.

.....

.....

..... [1]

[Total: 10]

- 2 In this experiment, you will investigate the rate of cooling of water.

You are provided with a supply of hot water and a supply of water at room temperature. Carry out the following instructions referring to Fig. 2.1.

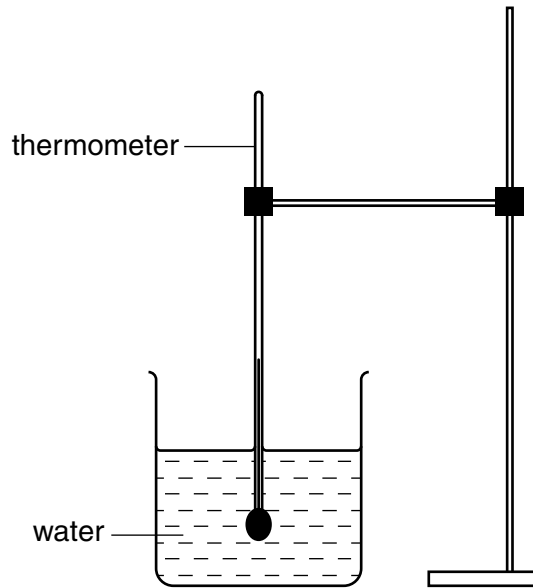

Fig. 2.1

- (a) Measure and record room temperature θ_R .

$$\theta_R = \dots\dots\dots [1]$$

- (b) (i) Pour 200 cm^3 of the hot water supplied into the beaker. Place the thermometer in the beaker of water.

Measure and record the temperature θ_0 of the water.

$$\theta_0 = \dots\dots\dots [1]$$

- (ii) Start the stopclock and record the temperature θ_1 of the water at time $t = 100 \text{ s}$.

$$\theta_1 = \dots\dots\dots [1]$$

- (iii) Calculate the temperature difference θ_A between θ_0 and room temperature θ_R using the equation $\theta_A = (\theta_0 - \theta_R)$.

$$\theta_A = \dots\dots\dots$$

- (iv) Calculate the temperature fall θ_H of the hot water using the equation $\theta_H = (\theta_0 - \theta_1)$.

$$\theta_H = \dots\dots\dots [1]$$

(c) Empty the beaker. Pour 100 cm³ of the hot water supplied into the beaker. Add 100 cm³ of the water at room temperature to the beaker. Briefly stir the water.

(i) Measure and record the temperature θ_2 of the warm water.

$$\theta_2 = \dots\dots\dots$$

(ii) Start the stopclock and record the temperature θ_3 of the water at time $t = 100$ s.

$$\theta_3 = \dots\dots\dots$$

[1]

(iii) Calculate the temperature difference θ_B between θ_2 and room temperature θ_R using the equation $\theta_B = (\theta_2 - \theta_R)$.

$$\theta_B = \dots\dots\dots$$

(iv) Calculate the temperature fall θ_W of the warm water using the equation $\theta_W = (\theta_2 - \theta_3)$.

$$\theta_W = \dots\dots\dots$$

[1]

(d) A student suggests that the rate of temperature change is proportional to the difference between the starting temperature and room temperature. This can be expressed as $\frac{\theta_A}{\theta_H} = \frac{\theta_B}{\theta_W}$.

State whether your results support this suggestion and justify your answer with reference to the results.

statement

justification

.....
.....
.....

[2]

(e) If this experiment were to be repeated in order to check the results, it would be important to control the conditions.

Suggest two such conditions that should be controlled.

1.

2.

[2]

[Total: 10]

- 3 In this experiment, you will investigate current and potential difference using lamps in series and parallel circuits.

Carry out the following instructions, referring to Figs. 3.1 and 3.2. The circuit shown in Fig. 3.1 is set up for you.

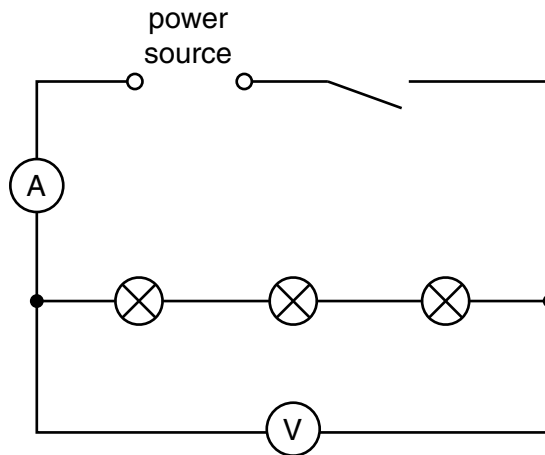

Fig. 3.1

- (a) (i) Switch on. Measure and record the current I_S in the lamps and the potential difference V_S across the three lamps. Switch off.

$$I_S = \dots\dots\dots$$

$$V_S = \dots\dots\dots$$

- (ii) Calculate the combined resistance R_S of the lamps using the equation $R_S = \frac{V_S}{I_S}$.

$$R_S = \dots\dots\dots$$

[3]

- (b) Rearrange the circuit as shown in Fig. 3.2. The ammeter is in position 1.

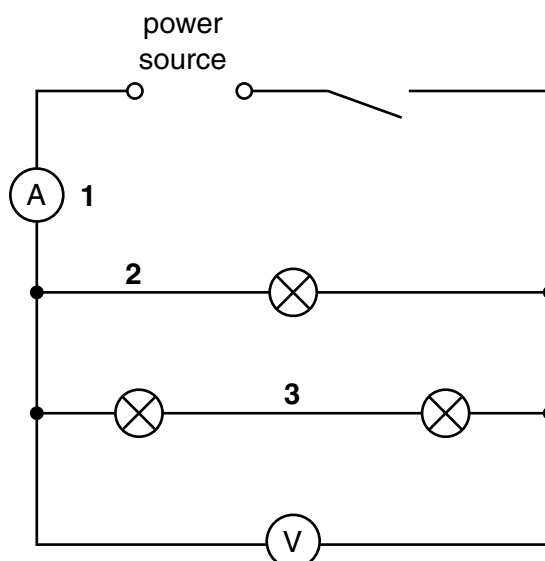

Fig. 3.2

- (i) Switch on. Measure and record the potential difference V_P across the combination of lamps.

$$V_P = \dots\dots\dots$$

- (ii) Measure and record the current I_1 . Switch off.

$$I_1 = \dots\dots\dots$$

- (iii) Move the ammeter to position **2** as shown in Fig. 3.2. Switch on. Measure and record the current I_2 . Switch off.

$$I_2 = \dots\dots\dots$$

- (iv) Move the ammeter to position **3** as shown in Fig. 3.2. Switch on. Measure and record the current I_3 . Switch off.

$$I_3 = \dots\dots\dots$$

- (v) Calculate the total current I_C using the equation $I_C = I_2 + I_3$.

$$I_C = \dots\dots\dots$$

- (vi) Calculate the total resistance R_P of the combination of the lamps, using the equation

$$R_P = \frac{V_P}{I_1} .$$

$$R_P = \dots\dots\dots$$

[5]

- (c) A student decides to investigate the effect on R_P of changing the current I_1 , using a variable resistor (rheostat).

In the space below, copy the diagram shown in Fig. 3.2, but with the addition of a variable resistor connected in the circuit at a suitable position for the investigation.

[2]

[Total: 10]

- 4 In this experiment, you will determine the focal length of a lens.

Carry out the following instructions, referring to Fig. 4.1.

For
Examiner's
Use

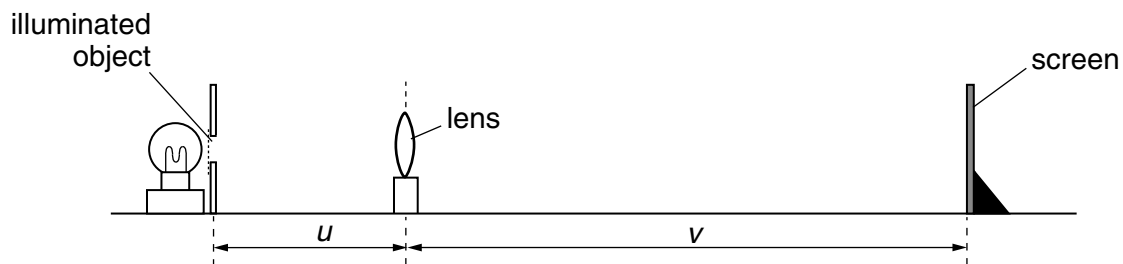

Fig. 4.1

- (a) Place the lens a distance $u = 30.0$ cm from the illuminated object. Move the screen until a sharply focused image of the object is seen on the screen.
- (i) Measure, and record in Table 4.1, the distance v between the centre of the lens and the screen.
 - (ii) Calculate uv and enter the value in the table.
 - (iii) Measure, and record in the table, the distance d between the illuminated object and the screen.
- (b) Repeat the steps in (a) using u values of 45.0 cm, 50.0 cm, 55.0 cm and 60.0 cm.

Table 4.1

u / cm	v / cm	uv / cm^2	d / cm
30.0			
45.0			
50.0			
55.0			
60.0			

[2]

- (c) Plot a graph of uv/cm^2 (y -axis) against d/cm (x -axis). You do **not** need to begin the axes at the origin (0,0).

For
Examiner's
Use

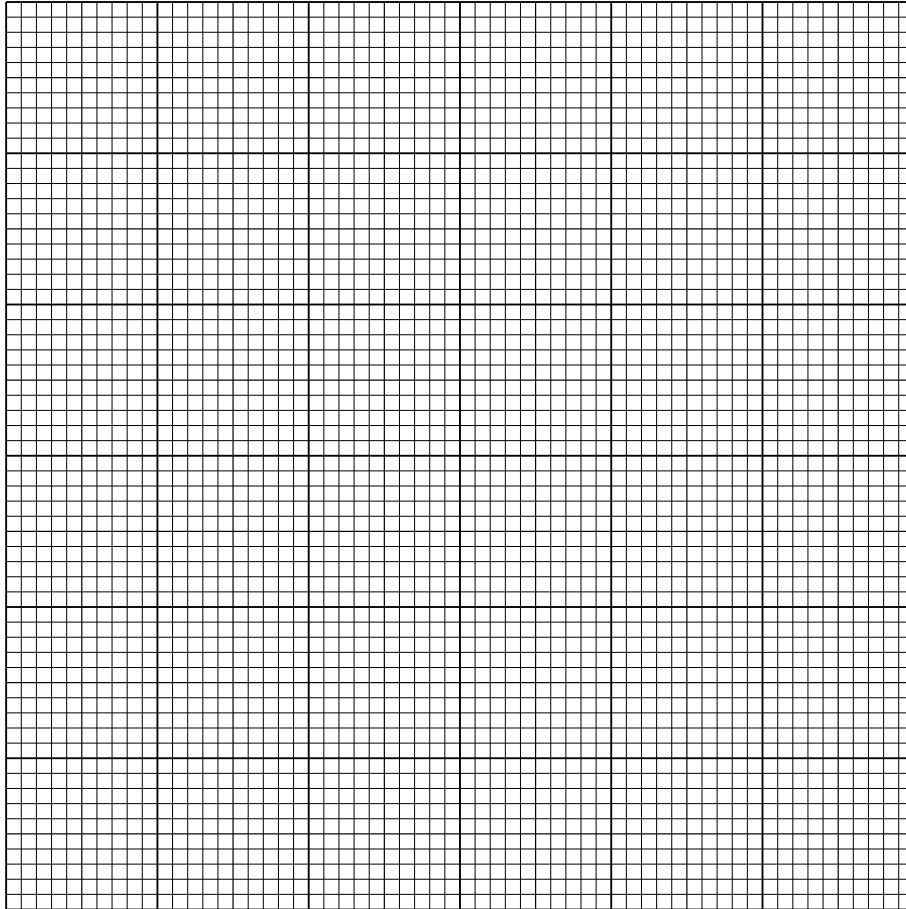

[4]

- (d) The gradient of the graph is numerically equal to the focal length of the lens.
- (i) Determine the gradient G of the graph. Show clearly on the graph how you obtained the necessary information.

$$G = \dots\dots\dots [2]$$

- (ii) State a value for the focal length f of the lens, giving your answer to a suitable number of significant figures for this experiment.

$$f = \dots\dots\dots [2]$$

[Total: 10]

BLANK PAGE

Permission to reproduce items where third-party owned material protected by copyright is included has been sought and cleared where possible. Every reasonable effort has been made by the publisher (UCLES) to trace copyright holders, but if any items requiring clearance have unwittingly been included, the publisher will be pleased to make amends at the earliest possible opportunity.

University of Cambridge International Examinations is part of the Cambridge Assessment Group. Cambridge Assessment is the brand name of University of Cambridge Local Examinations Syndicate (UCLES), which is itself a department of the University of Cambridge.