



UNIVERSITY OF CAMBRIDGE INTERNATIONAL EXAMINATIONS
International General Certificate of Secondary Education

CANDIDATE
NAME

CENTRE
NUMBER

--	--	--	--	--

CANDIDATE
NUMBER

--	--	--	--



PHYSICS

0625/21

Paper 2 Core

October/November 2012

1 hour 15 minutes

Candidates answer on the Question Paper.

No Additional Materials are required.

READ THESE INSTRUCTIONS FIRST

Write your Centre number, candidate number and name on all the work you hand in.

Write in dark blue or black pen.

You may use a pencil for any diagrams or graphs.

Do not use staples, paper clips, highlighters, glue or correction fluid.

DO NOT WRITE IN ANY BARCODES.

Answer **all** questions.

You may lose marks if you do not show your working or if you do not use appropriate units.

Take the weight of 1 kg to be 10 N (i.e. acceleration of free fall = 10 m/s²).

At the end of the examination, fasten all your work securely together.

The number of marks is given in brackets [] at the end of each question or part question.

For Examiner's Use

1	
2	
3	
4	
5	
6	
7	
8	
9	
10	
11	
12	
Total	

This document consists of **16** printed pages.



1 (a) State the name that is given to the turning effect of a force.

.....[1]

(b) A gate has rusty hinges that are very stiff. A man opens the gate by pulling on it, as shown in Fig. 1.1.

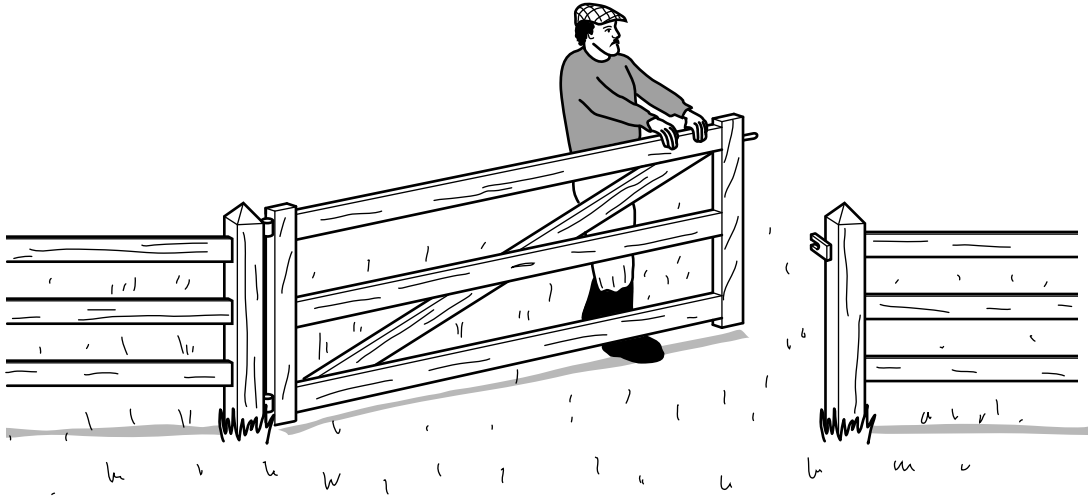

Fig. 1.1

After he has passed through the opening, he closes the gate behind him.

When closing the gate, the man pulls it at a point halfway along its length.

State two differences between his force when closing the gate and his force when he opened the gate.

1.

2.

[2]

(c) Suggest one way of reducing the force needed to open the gate.

.....[1]

[Total: 4]

2 (a) State the equation linking the density of a substance with its mass and volume.

.....
..... [1]

(b) When oil leaks out of a damaged oil-tanker, it forms a very thin layer of oil, known as an oil slick, on the water.

One such oil slick covers an approximately rectangular area measuring 2.5×10^4 m by 6.0×10^3 m.

The oil slick is 3.0×10^{-6} m (0.0000030 m) thick.

(i) Calculate the volume of the oil slick.

volume = m³ [3]

(ii) The density of the oil is 900 kg/m^3 .

Calculate the mass of oil in the slick.

mass = kg [2]

[Total: 6]

3 Fig. 3.1 shows four runners at the start of an 80 m race on a school sports day.

For
Examiner's
Use

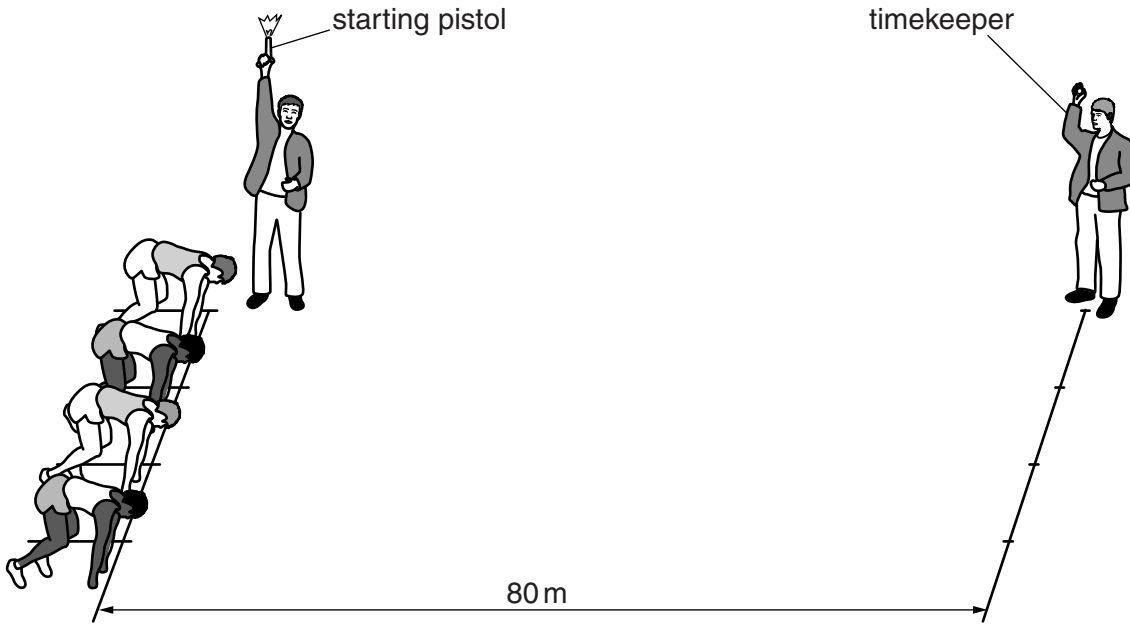

Fig. 3.1 (not to scale)

(a) Sound travels at 320 m/s.

Calculate the time taken for the sound from the starting pistol to reach the timekeeper.

time = s [3]

(b) The timekeeper takes 0.20 s to react after hearing the sound and then starts the stopwatch.

He makes no other experimental inaccuracies.

(i) By how much will his time for the race be in error?

time error = s [2]

(ii) Suggest how he can reduce this error, whilst still using the same stopwatch.

.....

 [1]

- (c) When he stops the stopwatch as the winner crosses the finishing line, the appearance of the stopwatch is as shown in Fig. 3.2.

*For
Examiner's
Use*

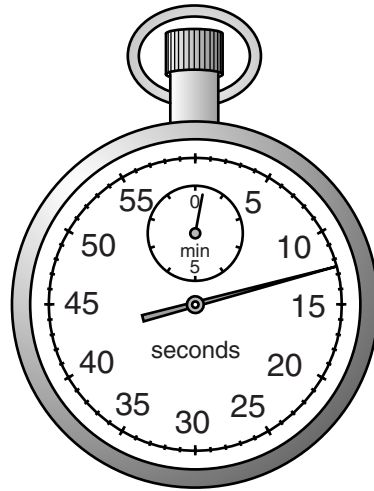

Fig. 3.2

How long did the winner actually take to run the race?

time = s [2]

[Total: 8]

- 4 An archer pulls the string of his bow, and moves the arrow to the position shown in Fig. 4.1. He then releases the string so that the arrow is fired towards a target.

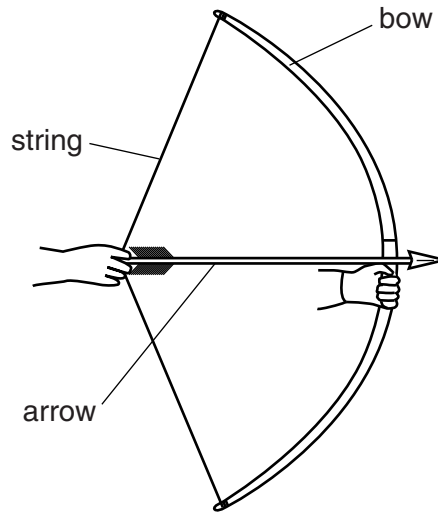

Fig. 4.1

- (a) The archer does work on the bow.

When is this work done? Tick one box.

as the string is pulled back to the position shown in Fig. 4.1

whilst holding the string in the position shown in Fig. 4.1

after releasing the string to fire the arrow

[1]

- (b) What type of energy is stored in the bow because it is bent?

.....[1]

- (c) What type of energy does the arrow have because it is moving?

.....[1]

- (d) On another occasion, the archer fires the arrow so that it rises up to a maximum height before falling back down to the ground.

Use words from the following list to complete the sentences below.

gravitational potential, kinetic, thermal, maximum, minimum, zero

As the arrow rises, its energy increases. At the top of the flight, this energy is at a As the arrow falls, this energy is converted into energy. When it hits the ground, the energy of the arrow is converted into energy.

[4]

[Total: 7]

5 (a) A metal ruler with a rectangular cross-section is heated in an oven.

(i) State two things that happen to the atoms of the metal.

1.

2.

[2]

(ii) State what happens to

1. the length of the ruler,

2. the width of the ruler,

3. the thickness of the ruler.

[2]

(b) The nut in Fig. 5.1 has become jammed on the bolt, so that it will not rotate.

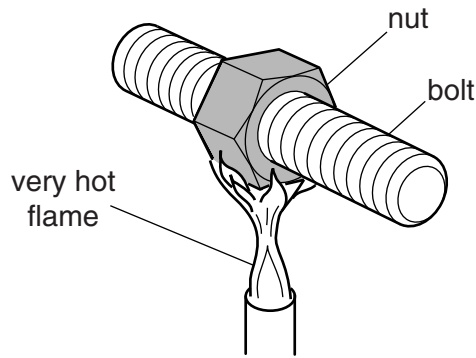

Fig. 5.1

Explain why heating the nut with a very hot flame is likely to free the jammed nut.

.....

.....

..... [2]

[Total: 6]

- 6 (a) In Fig. 6.1, a ray of red light is shown passing through a triangular glass prism and on to another prism that is identical but upside down.

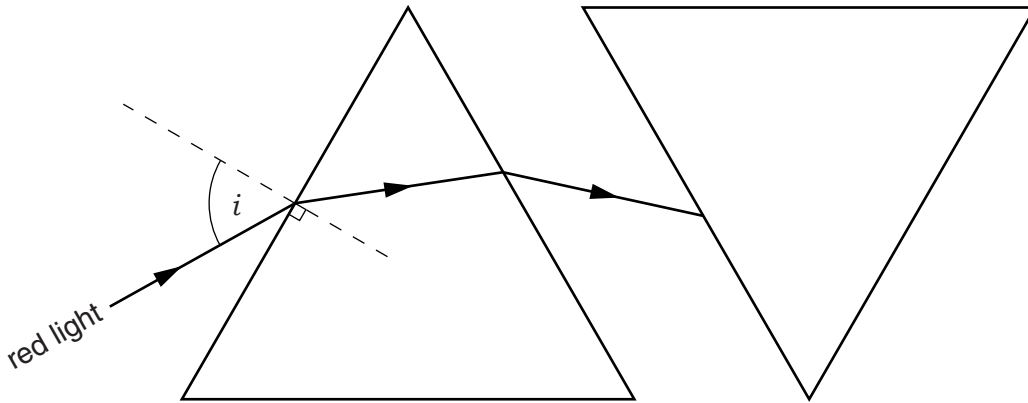

Fig. 6.1

- (i) The angle of incidence of the red light at the first surface is shown on Fig. 6.1 as i .

On Fig. 6.1, use the letter r to mark clearly the angle of refraction at the first surface. [1]

- (ii) On Fig. 6.1, complete the path of the ray through the right-hand prism and out into the air again. Label the emergent ray "line R". [3]

- (iii) The beam of red light is moved so that it shines into the right-hand prism along line R.

Using the letter P, mark clearly the point where this ray will emerge from the left-hand prism. [1]

- (b) On another occasion, a beam containing a mixture of red and blue light is shone into a prism, as shown in Fig. 6.2.

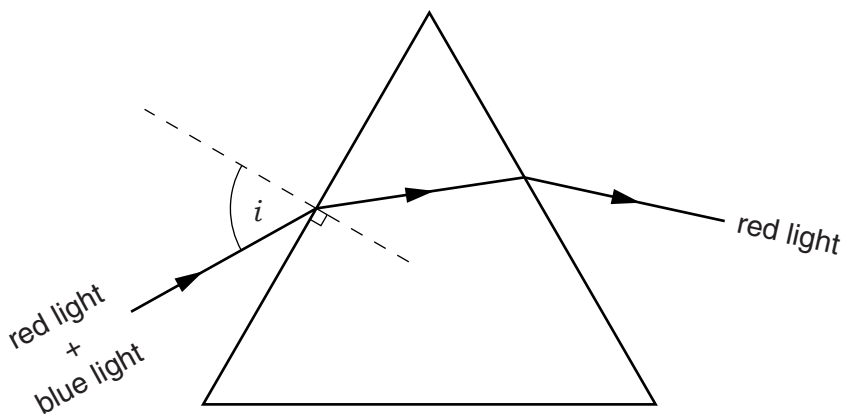

Fig. 6.2

- (i) On Fig. 6.2, draw the path of the blue light through the prism and out into the air again. [3]

(ii) Refraction is occurring at the first surface.

Which of the following is also occurring? Tick one box.

diffraction

dispersion

focusing

total internal reflection

*For
Examiner's
Use*

[1]

[Total: 9]

7 Fig. 7.1 shows a compass needle that has come to rest in the Earth's magnetic field.

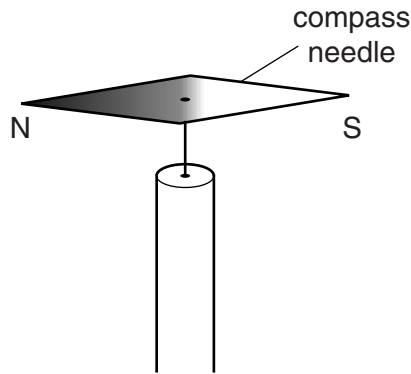

Fig. 7.1

- (a) On Fig. 7.1, draw an arrow pointing towards the north pole of the Earth. [1]
- (b) The S pole of a bar magnet is brought towards the S pole of the compass needle, as shown in Fig. 7.2.

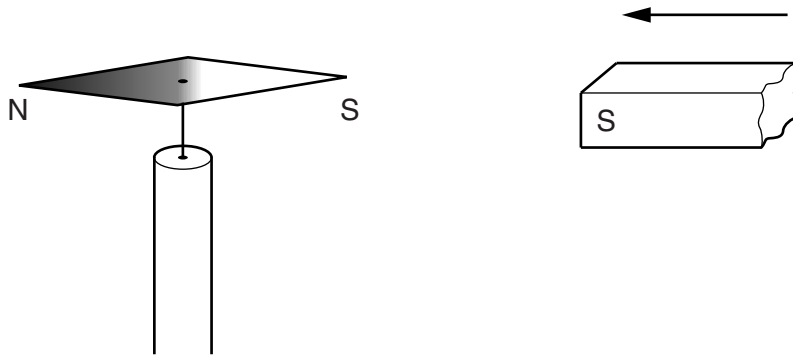

Fig. 7.2

Describe what is seen happening to the compass needle as this is done.

.....

.....

..... [2]

(c) The magnet in (b) is removed and a horizontal wire is positioned above the compass needle, as shown in Fig. 7.3.

*For
Examiner's
Use*

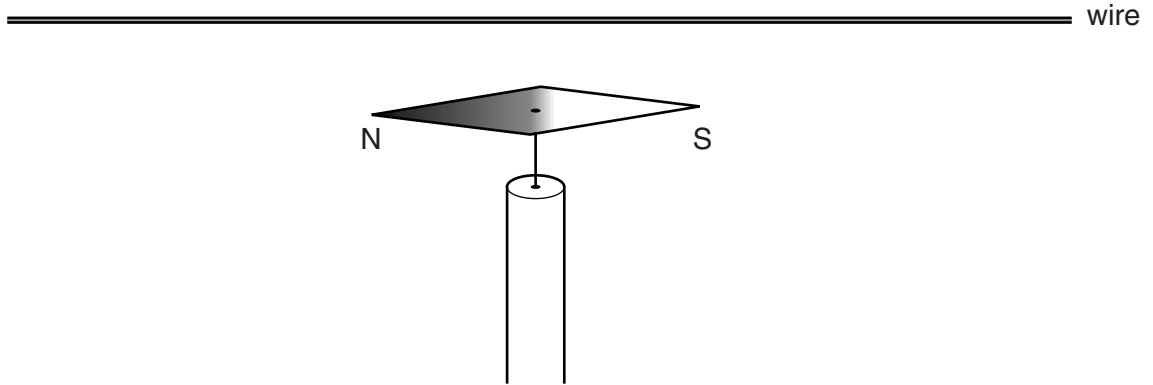

Fig. 7.3

When there is a current in the wire, the compass needle rotates through a small angle.

Suggest why this rotation occurs.

.....
.....
..... [2]

[Total: 5]

8 Fig. 8.1 shows a cell.

For
Examiner's
Use

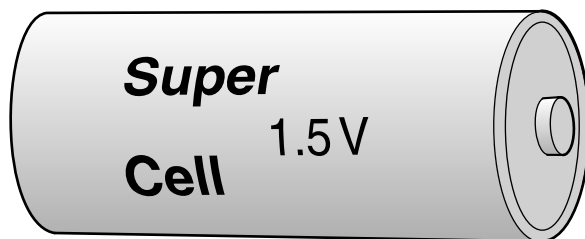

Fig. 8.1

(a) What does the 1.5V indicate about the cell?

.....[2]

(b) Three cells identical to the cell in Fig. 8.1 make up a 4.5V battery. The battery is connected in series with a $180\ \Omega$ resistor.

Calculate the current in the circuit.

current =[4]

(c) A second $180\ \Omega$ resistor is connected in parallel with the $180\ \Omega$ resistor from (b).

(i) In the space below, draw the circuit diagram of the two resistors in parallel, connected to the battery. Use standard symbols.

[3]

(ii) State the value of

1. the potential difference across the second $180\ \Omega$ resistor,

2. the current in the second $180\ \Omega$ resistor.

[2]

[Total: 11]

- 9 Fig. 9.1 shows a time-delay circuit that includes a capacitor C and a resistor of very high resistance.

For
Examiner's
Use

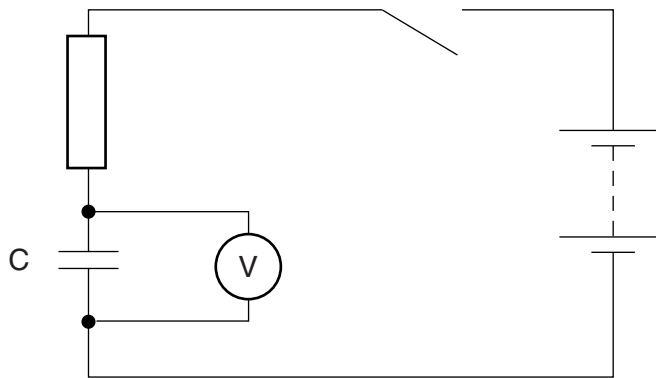

Fig. 9.1

- (a) On Fig. 9.1, use the letter S to label the switch. [1]

- (b) When the switch is open, the voltmeter in the circuit registers zero.

After the switch has been closed, what happens, if anything, to

- (i) the charge in the circuit,

.....
 [1]

- (ii) the reading on the voltmeter?

.....
 [2]

- (c) The switch is now opened again.

State what happens, if anything, to the reading on the voltmeter.

.....
 [1]

[Total: 5]

- 10 A 240V a.c. mains supply is connected to the primary coil of the transformer shown in Fig. 10.1. A lamp that gives full brightness with a 6V supply is connected to the secondary coil.

For
Examiner's
Use

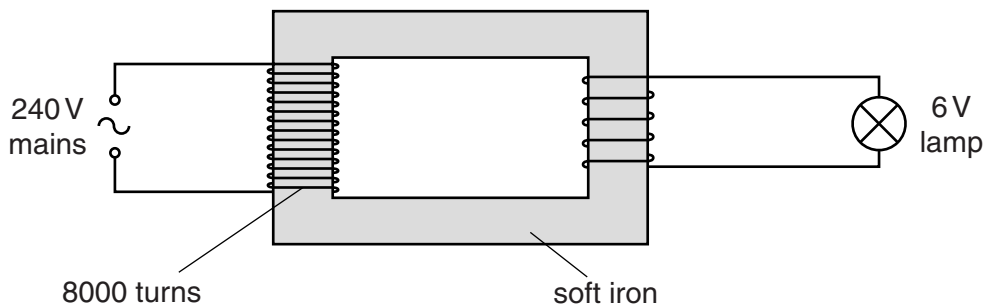

Fig. 10.1

- (a) Name a suitable material from which the coils may be made.
 [1]
- (b) State the name given to the part of the transformer that is made of soft iron (see Fig. 10.1).
 [1]
- (c) Calculate the number of turns of wire in the secondary coil that will enable the lamp to light at full brightness.

number of turns = [3]

- (d) State what would happen to the lamp if the number of turns in the secondary coil was
- (i) much less than that calculated in (c),
 [1]
- (ii) much more than that calculated in (c).
 [1]

[Total: 7]

- 11 The apparatus for investigating the absorption of the emissions from a radioactive source is shown in Fig. 11.1.

For
Examiner's
Use

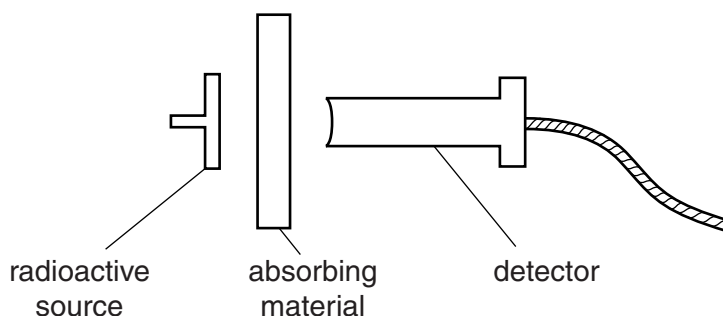

Fig. 11.1

The source and detector are about 2 cm apart. The detector is connected to a scaler, which measures the count rate.

Different absorbing materials are placed between the source and the detector.

The table below shows the count rate obtained with each of five absorbers.

absorbing material	$\frac{\text{count rate}}{\text{counts/s}}$
air	523
sheet of paper	523
0.5 mm of aluminium	391
10 mm of aluminium	214
10 mm of lead	122

- (a) How can you tell that the source is not emitting any α -particles?

.....

 [2]

- (b) What is the evidence that β -particles are being emitted?

.....

 [2]

- (c) What is the evidence that γ -rays are being emitted?

.....

 [2]

[Total: 6]

12 (a) The symbol for an α -particle is either ${}^4_2\alpha$ or ${}^4_2\text{He}$.

(i) What does the 4 indicate about an α -particle?

..... [1]

(ii) What does the 2 indicate about an α -particle?

..... [1]

(b) The symbol for a β -particle is either ${}^0_{-1}\beta$ or ${}^0_{-1}\text{e}$.

(i) What does the 0 indicate about a β -particle?

..... [1]

(ii) What does the -1 indicate about a β -particle?

..... [1]

(c) The list below gives, in nuclide notation, the symbols of five radioactive nuclides.



(i) ${}^{244}_{96}\text{Cm}$ decays by emitting an α -particle.

Into which of the other nuclides in the list does it decay? [1]

(ii) ${}^{250}_{97}\text{Bk}$ decays by emitting a β -particle.

Into which of the other nuclides in the list does it decay? [1]

[Total: 6]