



**Cambridge International Examinations**  
Cambridge International General Certificate of Secondary Education

CANDIDATE NAME

CENTRE NUMBER

CANDIDATE NUMBER



**PHYSICS**

**0625/52**

Paper 5 Practical Test

**May/June 2014**

**1 hour 15 minutes**

Candidates answer on the Question Paper.

Additional Materials: As listed in the Confidential Instructions.

**READ THESE INSTRUCTIONS FIRST**

Write your Centre number, candidate number and name in the spaces at the top of the page.

Write in dark blue or black pen.

You may use an HB pencil for any diagrams or graphs.

Do not use staples, paper clips, glue or correction fluid.

**DO NOT WRITE IN ANY BARCODES.**

Answer **all** questions.

Electronic calculators may be used.

You may lose marks if you do not show your working or if you do not use appropriate units.

At the end of the examination, fasten all your work securely together.

The number of marks is given in brackets [ ] at the end of each question or part question.

| For Examiner's Use |  |
|--------------------|--|
| 1                  |  |
| 2                  |  |
| 3                  |  |
| 4                  |  |
| <b>Total</b>       |  |

The syllabus is approved for use in England, Wales and Northern Ireland as a Cambridge International Level 1/Level 2 Certificate.

This document consists of **10** printed pages and **2** blank pages.

1 In this experiment, you will take measurements of a pencil.

Carry out the following instructions referring to Fig. 1.1.

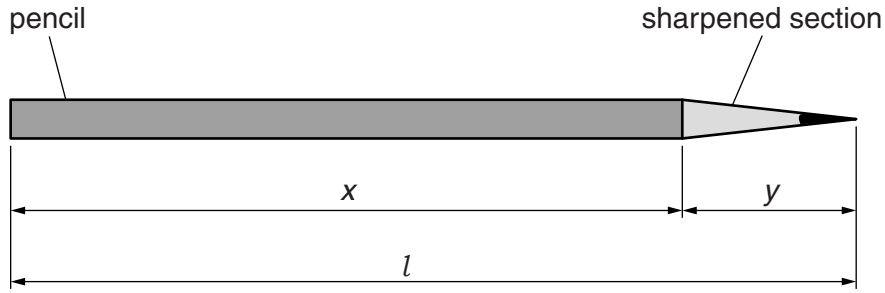

Fig. 1.1

(a) (i) Measure, in cm, the total length  $l$  of the pencil supplied.

$l = \dots\dots\dots$  cm

(ii) Measure, in cm, the length  $x$  of the unsharpened section of the pencil.

$x = \dots\dots\dots$  cm

(iii) Calculate the length  $y$  of the sharpened section of the pencil, using the equation  $y = (l - x)$ .

$y = \dots\dots\dots$  cm  
[2]

(b) Use the string and the ruler to determine the circumference  $c$  of the **unsharpened** section of the pencil. Show your working.

$c = \dots\dots\dots$  cm [3]

(c) Suggest a source of inaccuracy in determining the circumference of the pencil.

.....  
.....[1]

- (d) Calculate the volume  $V$  of the unsharpened section of the pencil using the equation  $V = \frac{c^2x}{4\pi}$ .

$$V = \dots\dots\dots[2]$$

- (e) Estimate the volume  $V_E$  of the **sharpened** section of the pencil. Show your working or reasoning.

$$V_E = \dots\dots\dots[2]$$

[Total: 10]

2 In this experiment, you will investigate the cooling of water.

Carry out the following instructions referring to Fig. 2.1.

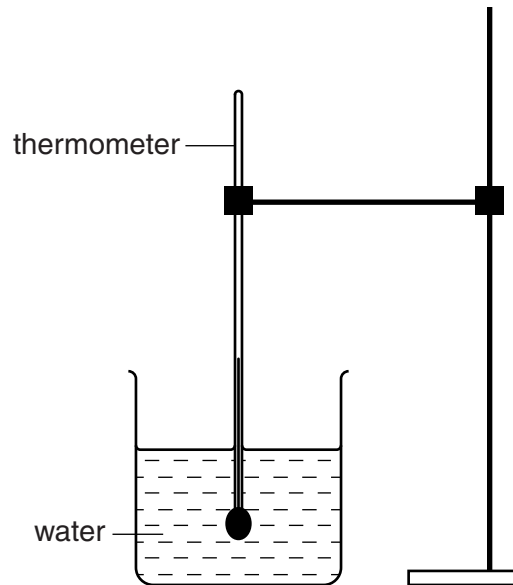

**Fig. 2.1**

- (a) Pour  $200\text{ cm}^3$  of hot water into the beaker. Place the thermometer in the beaker of hot water, as shown in Fig. 2.1.
- (i) When the thermometer reading stops rising, record in Table 2.1 the temperature  $\theta_H$  of the hot water at time  $t = 0\text{ s}$ . Immediately start the stopclock.
  - (ii) After 30s, measure the temperature  $\theta$  shown on the thermometer. Record the time  $t = 30\text{ s}$  and the temperature reading in the table.
  - (iii) Continue recording the time and temperature readings every 30s until you have six sets of readings.

**Table 2.1**

| $t/\text{s}$ | $\theta/^\circ\text{C}$ |
|--------------|-------------------------|
| 0            |                         |
|              |                         |
|              |                         |
|              |                         |
|              |                         |
|              |                         |

[2]

(b) Plot a graph of  $\theta / ^\circ\text{C}$  ( $y$ -axis) against  $t/\text{s}$  ( $x$ -axis).

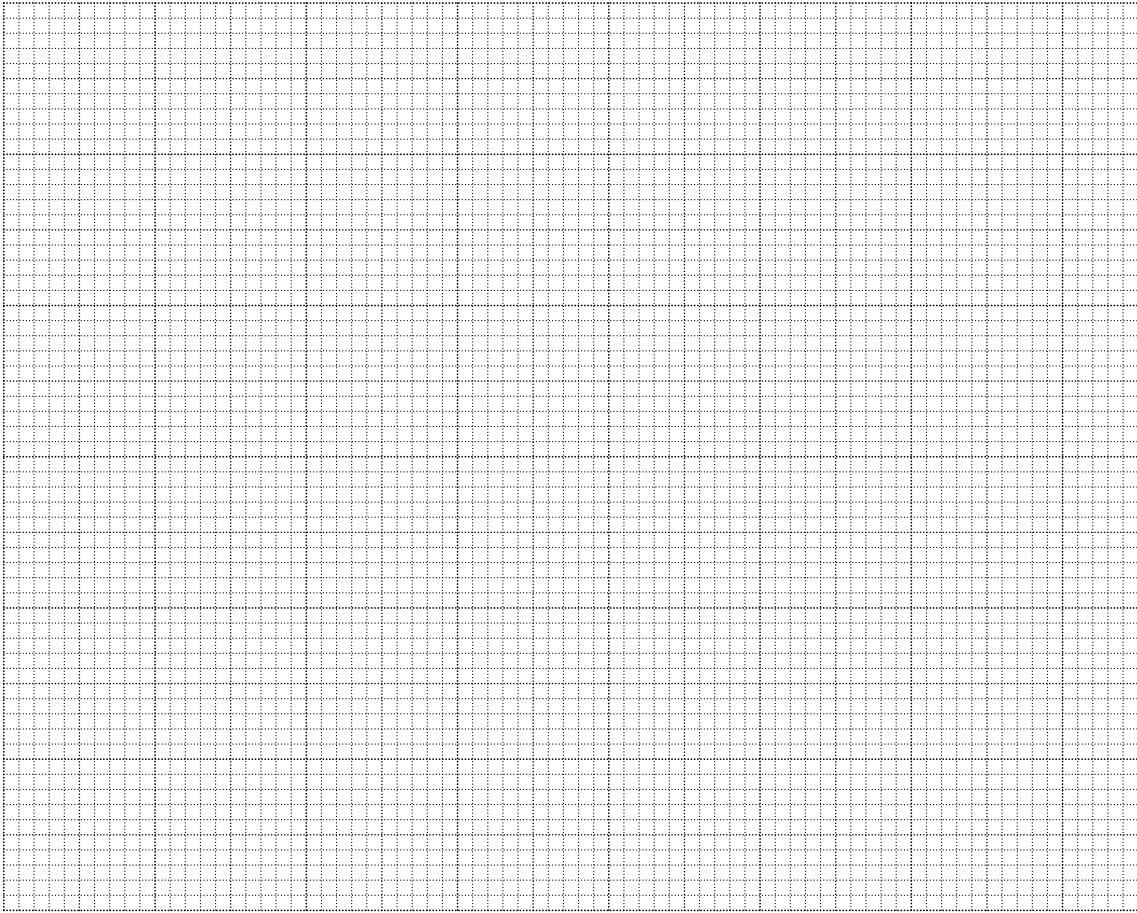

[5]

(c) (i) Describe briefly the shape of the best-fit graph line that you have drawn.

.....

(ii) State what the shape of the graph line tells you about the change, if any, in the rate of cooling of the water during the experiment.

.....

.....

[2]

(d) Describe briefly how you would read a measuring cylinder to obtain an accurate value for the volume of water. You may draw a diagram.

.....

.....

.....

.....[1]

[Total: 10]

**BLANK PAGE**

3 In this experiment, you will investigate the resistance of a resistor.

Carry out the following instructions, referring to Fig. 3.1.

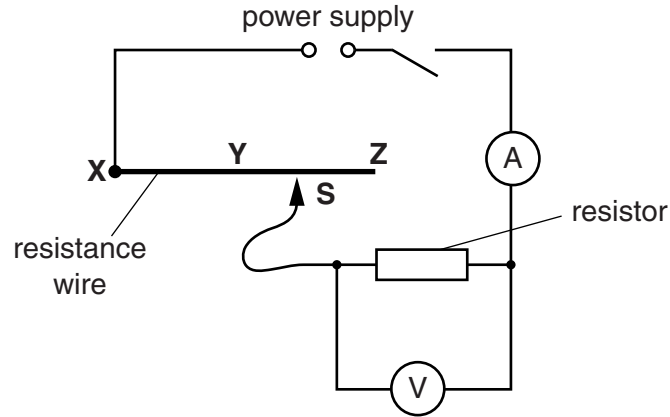

Fig. 3.1

- (a) (i) Switch on. Connect the sliding contact **S** to point **X** in the circuit. Measure and record the potential difference  $V$  across the resistor and the current  $I$  in the circuit. Switch off.

$V =$  .....

$I =$  .....

[2]

- (ii) Calculate the resistance  $R$  of the resistor using the equation  $R = \frac{V}{I}$ .

$R =$  .....[1]

- (b) (i) Switch on. Connect the sliding contact **S** to point **Y** in the circuit. Measure and record the potential difference  $V$  across the resistor and the current  $I$  in the circuit. Switch off.

$V =$  .....

$I =$  .....

[1]

- (ii) Calculate the resistance  $R$  of the resistor using the equation  $R = \frac{V}{I}$ .

$R =$  .....

- (c) (i) Switch on. Connect the sliding contact **S** to point **Z** in the circuit. Measure and record the potential difference  $V$  across the resistor and the current  $I$  in the circuit. Switch off.

$V =$  .....

$I =$  .....



(ii) Calculate the resistance  $R$  of the resistor using the equation  $R = \frac{V}{I}$ .

$R =$  ..... [2]

(d) State how the value of  $R$  changes when  $I$  decreases.

.....  
 ..... [1]

(e) A student carries out this experiment using a different resistor. He takes readings using various lengths of resistance wire in the circuit. He plots a graph of  $V/V$  against  $I/A$ .

Fig. 3.2 is a sketch of the graph.

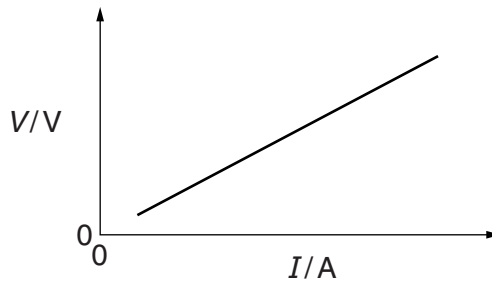

**Fig. 3.2**

Explain briefly how the student would use the graph to determine the gradient of the line. You may draw on the graph of Fig. 3.2. You are not asked to calculate the value of the gradient.

.....  
 .....  
 .....  
 ..... [2]

(f) In this experiment, the resistance wire **XYZ** acts as a variable resistor (rheostat).

Draw the standard circuit symbol for a variable resistor.

[1]

[Total: 10]

- 4 In this experiment, you will determine the focal length of a converging lens.

Carry out the following instructions, referring to Fig. 4.1.

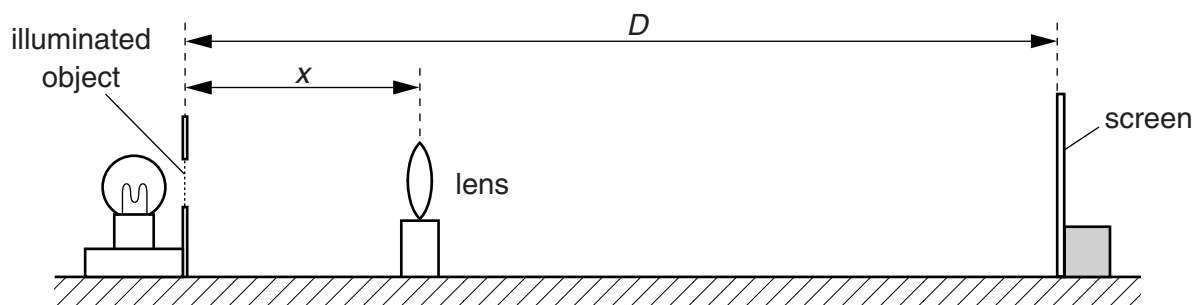

Fig 4.1

- (a) Place the screen at a distance  $D = 80.0\text{ cm}$  from the illuminated object. The screen and the illuminated object must remain in the same positions throughout the experiment.
- (b) Place the lens close to the illuminated object. Move the lens until a sharply-focused, enlarged image of the object is seen on the screen.

- (i) Measure and record, in cm, the distance  $x$  from the illuminated object to the centre of the lens.

$x = \dots\dots\dots\text{ cm}$

- (ii) Measure and record, in cm, the height  $h$  from the top to the bottom of the image on the screen.

$h = \dots\dots\dots\text{ cm}$   
[2]

- (c) Move the lens towards the screen until a smaller, sharply-focused image of the object is seen on the screen. Measure and record, in cm, the distance  $y$  from the illuminated object to the centre of the lens.

$y = \dots\dots\dots\text{ cm}$  [1]

- (d) (i) Calculate  $d$  using the equation  $d = (y - x)$ .

$d = \dots\dots\dots$

- (ii) Calculate  $d^2$ .

$d^2 = \dots\dots\dots$   
[1]

(e) Calculate the focal length  $f$  of the lens, using the equation  $f = \frac{D^2 - d^2}{4D}$ .

$f =$  .....[2]

(f) State two precautions that you could take in this experiment to obtain reliable results.

1. ....  
 .....  
 2. ....  
 ..... [2]

(g) Sketch a diagram of the image seen in part (b).

[1]

(h) Suggest a variable that could be changed when repeating this experiment to check the accuracy of the value obtained for the focal length  $f$ . You are not asked to repeat the experiment.

.....[1]

[Total: 10]

**BLANK PAGE**

---

Permission to reproduce items where third-party owned material protected by copyright is included has been sought and cleared where possible. Every reasonable effort has been made by the publisher (UCLES) to trace copyright holders, but if any items requiring clearance have unwittingly been included, the publisher will be pleased to make amends at the earliest possible opportunity.

Cambridge International Examinations is part of the Cambridge Assessment Group. Cambridge Assessment is the brand name of University of Cambridge Local Examinations Syndicate (UCLES), which is itself a department of the University of Cambridge.